



SPMA32-X	ROT.SP32X.198549
SPMA32-XP	ROT.SP32X.198723
SPMA32-XER	ROT.SP32X.199379
SPMA35-X	ROT.SP35X.199263
SPMA35-XE	ROT.SP35X.198990
SPMA35-XEV	ROT.SP35X.199416

2 SÄULEN HEBEBÜHNE
2 POST LIFT
SOLLEVATORE A 2 COLONNE
ELEVATEUR 2 COLONNES
ELEVADOR DE 2 COLUMNAS



OPERATION & MAINTENANCE MANUAL

Konformitätserklärung

Declaration of Conformity
Dichiarazione di Conformità
Déclaration de Conformité
Declaración de Conformidad



Wir
We / Noi / Nous / Nosotros

BlitzRotary GmbH
Hüfinger Str.55
78199 Bräunlingen, Germany

erklären unter unserer alleinigen Verantwortung, dass das Produkt

declare, undertaking sole responsibility, that the product
dichiariamo sotto la nostra esclusiva responsabilità che il prodotto
déclarons, sous notre entière responsabilité, que le produit.
declaramos bajo nuestra exclusiva responsabilidad, que el producto

Hebebühne für Fahrzeuge / Vehicles lift Sollevatore per veicoli / Elevateur de véhicule Elevador para vehículos ROT.SP32X.198549	
---	--

auf die sich diese Erklärung bezieht, den nachstehend anwendbaren Normen entspricht:

to which this declaration applies is in compliance with the following applicable Directive:
alla quale questa dichiarazione si riferisce, risponde alle seguenti Direttive applicabili:
objet de cette déclaration est conforme aux Directives applicables suivantes:
al que se refiere esta declaración cumple con las siguientes Normas aplicables:

2006/42/EG	Maschinenrichtlinie
2014/30/EU	Richtlinien über elektromagnetische Verträglichkeit
2014/35/EU	Richtlinien über elektrische Betriebsmittel

In Übereinstimmung mit o.g. Richtlinien wurden folgende harmonisierte Normen vollkommen befolgt:

To comply with the above mentioned Directive, we have followed, totally, the following harmonized directive:
Per la conformità alle suddette direttive sono state seguite, in modo totale, le seguenti Norme Armonizzate:
Pour la conformité aux normes ci-dessus, nous avons suivi, d'une façon totale, les normes harmonisées suivantes:
Para la conformidad a las Normas arriba mencionadas, hemos seguido, totalmente, las siguientes normas armonizadas:

EN 1493:2010	Fahrzeug-Hebebühnen
EN ISO 12100:2010	Sicherheit von Maschinen - Grundbegriffe
EN 60204-1:2018	Elektrische Ausrüstung von Maschinen

Vorgesetzte Rechtsperson für die Erstellung des technischen Lastenheftes ist BlitzRotary GmbH

The technical documentation file is constituted by BlitzRotary GmbH
La persona preposta a costruire il fascicolo tecnico è BlitzRotary GmbH
BlitzRotary GmbH est la personne délégué à la présentation de la documentation technique
BlitzRotary GmbH es encargado a la constitución del archivo técnico

Bräunlingen, / /

SIMONE FERRARI
VP VSG Europe Managing Director

DC16665 03/08/2022

Das Modell der vorliegenden Erklärung entspricht der Norm

The version of this declaration conforms to the regulation
Il modello della presente dichiarazione è conforme alla norma
Le modèle de la présente déclaration est conforme à la norme
El modelo de la presente declaración cumple la norma

EN ISO/IEC 17050-1



UK Declaration of Conformity



Wir
We / Noi / Nous / Nosotros

BlitzRotary GmbH
Hüfinger Str.55
78199 Bräunlingen, Germany

declare, undertaking sole responsibility, that the product

Vehicles lift ROT.SP32X.198549	
---------------------------------------	--

to which this declaration applies is in compliance with the following applicable Regulations:

The Supply of Machinery (Safety) Regulations 2008

Electromagnetic Compatibility Regulations 2016

To comply with the above mentioned Regulations, we have followed, totally, the following designated standards

BS EN ISO 12100:2010

Safety of machinery. General principles for design. Risk assessment and risk reduction

BS EN 1493:2010

Vehicles lifts

BS EN 60204-1:2018

Safety of machinery. Electrical equipment of machines. General requirements

The technical documentation file is constituted by

VEHICLE SERVICE GROUP UK LTD
3 Fourth Avenue
Bluebridge Industrial Estate
Halstead
Essex C09 2SY
United Kingdom

Sasso Marconi, / /

SIMONE FERRARI
VP VSG Europe Managing Director

UKDC16665 26/08/2022 The version of this declaration conform to the standard BS EN ISO/IEC 17050-1-2010

Konformitätserklärung

Declaration of Conformity
Dichiarazione di Conformità
Déclaration de Conformité
Declaración de Conformidad



Wir
We / Noi / Nous / Nosotros

BlitzRotary GmbH
Hüfinger Str.55
78199 Bräunlingen, Germany

erklären unter unserer alleinigen Verantwortung, dass das Produkt

declare, undertaking sole responsibility, that the product
dichiariamo sotto la nostra esclusiva responsabilità che il prodotto
déclarons, sous notre entière responsabilité, que le produit.
declaramos bajo nuestra exclusiva responsabilidad, que el producto

Hebebühne für Fahrzeuge / Vehicles lift Sollevatore per veicoli / Elevateur de véhicule Elevador para vehículos ROT.SP32X.198723	
---	--

auf die sich diese Erklärung bezieht, den nachstehend anwendbaren Normen entspricht:

to which this declaration applies is in compliance with the following applicable Directive:
alla quale questa dichiarazione si riferisce, risponde alle seguenti Direttive applicabili:
objet de cette déclaration est conforme aux Directives applicables suivantes:
al que se refiere esta declaración cumple con las siguientes Normas aplicables:

2006/42/EG	Maschinenrichtlinie
2014/30/EU	Richtlinien über elektromagnetische Verträglichkeit
2014/35/EU	Richtlinien über elektrische Betriebsmittel

In Übereinstimmung mit o.g. Richtlinien wurden folgende harmonisierte Normen vollkommen befolgt:

To comply with the above mentioned Directive, we have followed, totally, the following harmonized directive:
Per la conformità alle suddette direttive sono state seguite, in modo totale, le seguenti Norme Armonizzate:
Pour la conformité aux normes ci-dessus, nous avons suivi, d'une façon totale, les normes harmonisées suivantes:
Para la conformidad a las Normas arriba mencionadas, hemos seguido, totalmente, las siguientes normas armonizadas:

EN 1493:2010	Fahrzeug-Hebebühnen
EN ISO 12100:2010	Sicherheit von Maschinen - Grundbegriffe
EN 60204-1:2018	Elektrische Ausrüstung von Maschinen

Vorgesetzte Rechtsperson für die Erstellung des technischen Lastenheftes ist BlitzRotary GmbH

The technical documentation file is constituted by BlitzRotary GmbH
La persona preposta a costruire il fascicolo tecnico è BlitzRotary GmbH
BlitzRotary GmbH est la personne délégué à la présentation de la documentation technique
BlitzRotary GmbH es encargado a la constitución del archivo técnico

Bräunlingen, / /

SIMONE FERRARI
VP VSG Europe Managing Director

DC16664 03/08/2022

Das Modell der vorliegenden Erklärung entspricht der Norm

The version of this declaration conforms to the regulation
Il modello della presente dichiarazione è conforme alla norma
Le modèle de la présente déclaration est conforme à la norme
El modelo de la presente declaración cumple la norma

EN ISO/IEC 17050-1

UK Declaration of Conformity

Wir
We / Noi / Nous / Nosotros

BlitzRotary GmbH
Hüfinger Str.55
78199 Bräunlingen, Germany

declare, undertaking sole responsibility, that the product

Vehicles lift ROT.SP32X.198723	
---------------------------------------	--

to which this declaration applies is in compliance with the following applicable Regulations:

The Supply of Machinery (Safety) Regulations 2008

Electromagnetic Compatibility Regulations 2016

To comply with the above mentioned Regulations, we have followed, totally, the following designated standards

BS EN ISO 12100:2010

Safety of machinery. General principles for design. Risk assessment and risk reduction

BS EN 1493:2010

Vehicles lifts

BS EN 60204-1:2018

Safety of machinery. Electrical equipment of machines. General requirements

The technical documentation file is constituted by

VEHICLE SERVICE GROUP UK LTD
3 Fourth Avenue
Bluebridge Industrial Estate
Halstead
Essex C09 2SY
United Kingdom

Sasso Marconi, / /

SIMONE FERRARI
VP VSG Europe Managing Director



UKDC16664 26/08/2022 The version of this declaration conform to the standard BS EN ISO/IEC 17050-1-2010

Konformitätserklärung

Declaration of Conformity
Dichiarazione di Conformità
Déclaration de Conformité
Declaración de Conformidad



Wir
We / Noi / Nous / Nosotros

BlitzRotary GmbH
Hüfinger Str.55
78199 Bräunlingen, Germany

erklären unter unserer alleinigen Verantwortung, dass das Produkt

declare, undertaking sole responsibility, that the product
dichiariamo sotto la nostra esclusiva responsabilità che il prodotto
déclarons, sous notre entière responsabilité, que le produit.
declaramos bajo nuestra exclusiva responsabilidad, que el producto

Hebebühne für Fahrzeuge / Vehicles lift Sollevatore per veicoli / Elevateur de véhicule Elevador para vehículos ROT.SP32X.199379	
---	--

auf die sich diese Erklärung bezieht, den nachstehend anwendbaren Normen entspricht:

to which this declaration applies is in compliance with the following applicable Directive:
alla quale questa dichiarazione si riferisce, risponde alle seguenti Direttive applicabili:
objet de cette déclaration est conforme aux Directives applicables suivantes:
al que se refiere esta declaración cumple con las siguientes Normas aplicables:

2006/42/EG	Maschinenrichtlinie
2014/30/EU	Richtlinien über elektromagnetische Verträglichkeit
2014/35/EU	Richtlinien über elektrische Betriebsmittel

In Übereinstimmung mit o.g. Richtlinien wurden folgende harmonisierte Normen vollkommen befolgt:

To comply with the above mentioned Directive, we have followed, totally, the following harmonized directive:
Per la conformità alle suddette direttive sono state seguite, in modo totale, le seguenti Norme Armonizzate:
Pour la conformité aux normes ci-dessus, nous avons suivi, d'une façon totale, les normes harmonisées suivantes:
Para la conformidad a las Normas arriba mencionadas, hemos seguido, totalmente, las siguientes normas armonizadas:

EN 1493:2010	Fahrzeug-Hebebühnen
EN ISO 12100:2010	Sicherheit von Maschinen - Grundbegriffe
EN 60204-1:2018	Elektrische Ausrüstung von Maschinen

Vorgesetzte Rechtsperson für die Erstellung des technischen Lastenheftes ist BlitzRotary GmbH

The technical documentation file is constituted by BlitzRotary GmbH
La persona preposta a costruire il fascicolo tecnico è BlitzRotary GmbH
BlitzRotary GmbH est la personne délégué à la présentation de la documentation technique
BlitzRotary GmbH es encargado a la constitución del archivo técnico

SIMONE FERRARI
VP VSG Europe Managing Director

Bräunlingen, / /

DC16670 03/08/2022

Das Modell der vorliegenden Erklärung entspricht der Norm
The version of this declaration conforms to the regulation
Il modello della presente dichiarazione è conforme alla norma
Le modèle de la présente déclaration est conforme à la norme
El modelo de la presente declaración cumple la norma

EN ISO/IEC 17050-1



UK Declaration of Conformity



Wir
We / Noi / Nous / Nosotros

BlitzRotary GmbH
Hüfinger Str.55
78199 Bräunlingen, Germany

declare, undertaking sole responsibility, that the product

Vehicles lift ROT.SP32X.199379	
---------------------------------------	--

to which this declaration applies is in compliance with the following applicable Regulations:

The Supply of Machinery (Safety) Regulations 2008

Electromagnetic Compatibility Regulations 2016

To comply with the above mentioned Regulations, we have followed, totally, the following designated standards

BS EN ISO 12100:2010

Safety of machinery. General principles for design. Risk assessment and risk reduction

BS EN 1493:2010

Vehicles lifts

BS EN 60204-1:2018

Safety of machinery. Electrical equipment of machines. General requirements

The technical documentation file is constituted by

VEHICLE SERVICE GROUP UK LTD
3 Fourth Avenue
Bluebridge Industrial Estate
Halstead
Essex C09 2SY
United Kingdom

SIMONE FERRARI
VP VSG Europe Managing Director

Sasso Marconi, / /

UKDC16670 26/08/2022 The version of this declaration conform to the standard BS EN ISO/IEC 17050-1-2010

Konformitätserklärung

Declaration of Conformity
Dichiarazione di Conformità
Déclaration de Conformité
Declaración de Conformidad



Wir
We / Noi / Nous / Nosotros

BlitzRotary GmbH
Hüfinger Str.55
78199 Bräunlingen, Germany

erklären unter unserer alleinigen Verantwortung, dass das Produkt

declare, undertaking sole responsibility, that the product
dichiariamo sotto la nostra esclusiva responsabilità che il prodotto
déclarons, sous notre entière responsabilité, que le produit.
declaramos bajo nuestra exclusiva responsabilidad, que el producto

Hebebühne für Fahrzeuge / Vehicles lift Sollevatore per veicoli / Elevateur de véhicule Elevador para vehículos ROT.SP35X.198990	
---	--

auf die sich diese Erklärung bezieht, den nachstehend anwendbaren Normen entspricht:

to which this declaration applies is in compliance with the following applicable Directive:
alla quale questa dichiarazione si riferisce, risponde alle seguenti Direttive applicabili:
objet de cette déclaration est conforme aux Directives applicables suivantes:
al que se refiere esta declaración cumple con las siguientes Normas aplicables:

2006/42/EG	Maschinenrichtlinie
2014/30/EU	Richtlinien über elektromagnetische Verträglichkeit
2014/35/EU	Richtlinien über elektrische Betriebsmittel

In Übereinstimmung mit o.g. Richtlinien wurden folgende harmonisierte Normen vollkommen befolgt:

To comply with the above mentioned Directive, we have followed, totally, the following harmonized directive:
Per la conformità alle suddette direttive sono state seguite, in modo totale, le seguenti Norme Armonizzate:
Pour la conformité aux normes ci-dessus, nous avons suivi, d'une façon totale, les normes harmonisées suivantes:
Para la conformidad a las Normas arriba mencionadas, hemos seguido, totalmente, las siguientes normas armonizadas:

EN 1493:2010	Fahrzeug-Hebebühnen
EN ISO 12100:2010	Sicherheit von Maschinen - Grundbegriffe
EN 60204-1:2018	Elektrische Ausrüstung von Maschinen

Vorgesetzte Rechtsperson für die Erstellung des technischen Lastenheftes ist BlitzRotary GmbH

The technical documentation file is constituted by BlitzRotary GmbH
La persona preposta a costruire il fascicolo tecnico è BlitzRotary GmbH
BlitzRotary GmbH est la personne délégué à la présentation de la documentation technique
BlitzRotary GmbH es encargado a la constitución del archivo técnico

Bräunlingen, / /

SIMONE FERRARI
VP VSG Europe Managing Director

DC16663 03/08/2022

Das Modell der vorliegenden Erklärung entspricht der Norm

The version of this declaration conforms to the regulation
Il modello della presente dichiarazione è conforme alla norma
Le modèle de la présente déclaration est conforme à la norme
El modelo de la presente declaración cumple la norma

EN ISO/IEC 17050-1



UK Declaration of Conformity



Wir
We / Noi / Nous / Nosotros

BlitzRotary GmbH
Hüfanger Str.55
78199 Bräunlingen, Germany

declare, undertaking sole responsibility, that the product

Vehicles lift ROT.SP35X.198990	
---------------------------------------	--

to which this declaration applies is in compliance with the following applicable Regulations:

The Supply of Machinery (Safety) Regulations 2008

Electromagnetic Compatibility Regulations 2016

To comply with the above mentioned Regulations, we have followed, totally, the following designated standards

BS EN ISO 12100:2010
BS EN 1493:2010
BS EN 60204-1:2018

Safety of machinery. General principles for design. Risk assessment and risk reduction
Vehicles lifts
Safety of machinery. Electrical equipment of machines. General requirements

The technical documentation file is constituted by

VEHICLE SERVICE GROUP UK LTD
3 Fourth Avenue
Bluebridge Industrial Estate
Halstead
Essex C09 2SY
United Kingdom

SIMONE FERRARI
VP VSG Europe Managing Director

Sasso Marconi, / /

UKDC16663 26/08/2022 The version of this declaration conform to the standard BS EN ISO/IEC 17050-1-2010

Konformitätserklärung

Declaration of Conformity
Dichiarazione di Conformità
Déclaration de Conformité
Declaración de Conformidad



Wir
We / Noi / Nous / Nosotros

BlitzRotary GmbH
Hüfinger Str.55
78199 Bräunlingen, Germany

erklären unter unserer alleinigen Verantwortung, dass das Produkt

declare, undertaking sole responsibility, that the product
dichiariamo sotto la nostra esclusiva responsabilità che il prodotto
déclarons, sous notre entière responsabilité, que le produit.
declaramos bajo nuestra exclusiva responsabilidad, que el producto

Hebebühne für Fahrzeuge / Vehicles lift Sollevatore per veicoli / Elevateur de véhicule Elevador para vehículos ROT.SP35X.199263	
---	--

auf die sich diese Erklärung bezieht, den nachstehend anwendbaren Normen entspricht:

to which this declaration applies is in compliance with the following applicable Directive:
alla quale questa dichiarazione si riferisce, risponde alle seguenti Direttive applicabili:
objet de cette déclaration est conforme aux Directives applicables suivantes:
al que se refiere esta declaración cumple con las siguientes Normas aplicables:

2006/42/EG	Maschinenrichtlinie
2014/30/EU	Richtlinien über elektromagnetische Verträglichkeit
2014/35/EU	Richtlinien über elektrische Betriebsmittel

In Übereinstimmung mit o.g. Richtlinien wurden folgende harmonisierte Normen vollkommen befolgt:

To comply with the above mentioned Directive, we have followed, totally, the following harmonized directive:
Per la conformità alle suddette direttive sono state seguite, in modo totale, le seguenti Norme Armonizzate:
Pour la conformité aux normes ci-dessus, nous avons suivi, d'une façon totale, les normes harmonisées suivantes:
Para la conformidad a las Normas arriba mencionadas, hemos seguido, totalmente, las siguientes normas armonizadas:

EN 1493:2010	Fahrzeug-Hebebühnen
EN ISO 12100:2010	Sicherheit von Maschinen - Grundbegriffe
EN 60204-1:2018	Elektrische Ausrüstung von Maschinen

Vorgesetzte Rechtsperson für die Erstellung des technischen Lastenheftes ist BlitzRotary GmbH

The technical documentation file is constituted by BlitzRotary GmbH
La persona preposta a costruire il fascicolo tecnico è BlitzRotary GmbH
BlitzRotary GmbH est la personne délégué à la présentation de la documentation technique
BlitzRotary GmbH es encargado a la constitución del archivo técnico

Bräunlingen, / /

SIMONE FERRARI
VP VSG Europe Managing Director



DC16662 03/08/2022

Das Modell der vorliegenden Erklärung entspricht der Norm

The version of this declaration conforms to the regulation
Il modello della presente dichiarazione è conforme alla norma
Le modèle de la présente déclaration est conforme à la norme
El modelo de la presente declaración cumple la norma

EN ISO/IEC 17050-1

UK Declaration of Conformity



Wir
We / Noi / Nous / Nosotros

BlitzRotary GmbH
Hüfinger Str.55
78199 Bräunlingen, Germany

declare, undertaking sole responsibility, that the product

Vehicles lift ROT.SP35X.199263	
---------------------------------------	--

to which this declaration applies is in compliance with the following applicable Regulations:

The Supply of Machinery (Safety) Regulations 2008

Electromagnetic Compatibility Regulations 2016

To comply with the above mentioned Regulations, we have followed, totally, the following designated standards

BS EN ISO 12100:2010

Safety of machinery. General principles for design. Risk assessment and risk reduction

BS EN 1493:2010

Vehicles lifts

BS EN 60204-1:2018

Safety of machinery. Electrical equipment of machines. General requirements

The technical documentation file is constituted by

VEHICLE SERVICE GROUP UK LTD
3 Fourth Avenue
Bluebridge Industrial Estate
Halstead
Essex C09 2SY
United Kingdom

SIMONE FERRARI
VP VSG Europe Managing Director



Sasso Marconi, / /

UKDC16662 26/08/2022 The version of this declaration conform to the standard BS EN ISO/IEC 17050-1-2010

Konformitätserklärung

*Declaration of Conformity
Dichiarazione di Conformità
Déclaration de Conformité
Declaración de Conformidad*



Wir
We / Noi / Nous / Nosotros

BlitzRotary GmbH
Hüfinger Str.55
78199 Bräunlingen, Germany

erklären unter unserer alleinigen Verantwortung, dass das Produkt
declare, undertaking sole responsibility, that the product
dichiariamo sotto la nostra esclusiva responsabilità che il prodotto
déclarons, sous notre entière responsabilité, que le produit,
declaramos bajo nuestra exclusiva responsabilidad, que el producto

Hebebühne für Fahrzeuge / Vehicles lift
Sollevatore per veicoli / Elevateur de véhicule
Elevador para vehículos

ROT.SP35X.199416

auf die sich diese Erklärung bezieht, den nachstehend anwendbaren Normen entspricht:

to which this declaration applies is in compliance with the following applicable Directive:
alla quale questa dichiarazione si riferisce, risponde alle seguenti Direttive applicabili:
objet de cette déclaration est conforme aux Directives applicables suivantes:
al que se refiere esta declaración cumple con las siguientes Normas aplicables:

2006/42/EG	Maschinenrichtlinie
2014/30/EU	Richtlinien über elektromagnetische Verträglichkeit
2014/35/EU	Richtlinien über elektrische Betriebsmittel

In Übereinstimmung mit o.g. Richtlinien wurden folgende harmonisierte Normen vollkommen befolgt:

To comply with the above mentioned Directive, we have followed, totally, the following harmonized directive:
Per la conformità alle suddette direttive sono state seguite, in modo totale, le seguenti Norme Armonizzate:
Pour la conformité aux normes ci-dessus, nous avons suivi, d'une façon totale, les normes harmonisées suivantes:
Para la conformidad a las Normas arriba mencionadas, hemos seguido, totalmente, las siguientes normas armonizadas:

EN 1493:2010	Fahrzeug-Hebebühnen
EN ISO 12100:2010	Sicherheit von Maschinen - Grundbegriffe
EN 60204-1:2018	Elektrische Ausrüstung von Maschinen

Vorgesetzte Rechtsperson für die Erstellung des technischen Lastenheftes ist BlitzRotary GmbH
The technical documentation file is constituted by BlitzRotary GmbH
La persona preposta a costruire il fascicolo tecnico è BlitzRotary GmbH
BlitzRotary GmbH est la personne délégué à la présentation de la documentation technique
BlitzRotary GmbH es encargado a la constitución del archivo técnico

SIMONE FERRARI
VP VSG Europe Managing Director

Bräunlingen, / /

DC16672 03/08/2022

Das Modell der vorliegenden Erklärung entspricht der Norm
The version of this declaration conforms to the regulation
Il modello della presente dichiarazione è conforme alla norma
Le modèle de la présente déclaration est conforme à la norme
El modelo de la presente declaración cumple la norma

EN ISO/IEC 17050-1

UK Declaration of Conformity

Wir
We / Noi / Nous / Nosotros

BlitzRotary GmbH
Hüfnger Str.55
78199 Bräunlingen, Germany

declare, undertaking sole responsibility, that the product

Vehicles lift ROT.SP35X.199416	
---------------------------------------	--

to which this declaration applies is in compliance with the following applicable Regulations:

The Supply of Machinery (Safety) Regulations 2008
Electromagnetic Compatibility Regulations 2016

To comply with the above mentioned Regulations, we have followed, totally, the following designated standards

BS EN ISO 12100:2010	Safety of machinery. General principles for design. Risk assessment and risk reduction
BS EN 1493:2010	Vehicles lifts
BS EN 60204-1:2018	Safety of machinery. Electrical equipment of machines. General requirements

The technical documentation file is constituted by

VEHICLE SERVICE GROUP UK LTD
3 Fourth Avenue
Bluebridge Industrial Estate
Halstead
Essex C09 2SY
United Kingdom

SIMONE FERRARI
VP VSG Europe Managing Director



Sasso Marconi, / /

UKDC16672 26/08/2022 The version of this declaration conform to the standard BS EN ISO/IEC 17050-1-2010

DEUTSCH

ENGLISH

ITALIANO

FRANÇAIS

ESPAÑOL

ATTACHED



[TEq-Link Workshop - Download DE](#)

[TEq-Link Workshop - Download EN](#)

[TEq-Link Workshop - Download IT](#)

[TEq-Link Workshop - Download FR](#)

[TEq-Link Workshop - Download ES](#)

<p>COMPOSIZIONE DEL MANUALE 206 pagine (comprese le copertine)</p>	<p>COMPOSITION OF MANUAL 206 pages (including cover pages)</p>	<p>ZUSAMMENSETZUNG DER ANLEITUNG 206 Seiten (inkl. Deckblätter)</p>	<p>COMPOSITION DE LA NOTICE 206 pages (pages de la couverture incluses)</p>	<p>COMPOSICIÓN DEL MANUALE 206 páginas (incluidas las cubiertas)</p>
---	---	--	--	---

INHALTSVERZEICHNIS

KAP. 1	IN DER BEDIENUGSANLEITUNG VERWENDETE ZEICHEN	DE_2
KAP. 2	PRÄSENTATION	DE_3
2.1	BESCHREIBUNG DER HEBEBÜHNE	DE_3
2.2	BESTIMMUNGSGEMÄSSE VERWENDUNG	DE_3
KAP. 3	TECHNISCHE DATEN	DE_4
3.1	TECHNISCHE HAUPTZEICHEN	DE_4
3.2	GENERAL TECHNICAL DETAILS.....	DE_5
3.3	KENNZEICHNUNGSDATEN DER MASCHINE.....	DE_7
3.4	HAUPTBEDIENELEMENTE DER HEBEBÜHNE	DE_8
3.5.	ELEKTROANLAGE	DE_9
KAP. 4	ALLGEMEINE SICHERHEITSVORSCHRIFTEN	DE_17
4.1	HINWEISE ZU DEN RESTRISIKEN	DE_17
4.2	SICHERHEITSSCHILDER UND/ODER -AUFKLEBER	DE_17
4.3	SCHULUNG DES BEDIENUNGSPERSONALS	DE_17
4.4	BETRIEBSTÜCHTIGKEIT	DE_17
KAP. 5	ANFORDERUNGEN FÜR DIE INSTALLATION	DE_18
5.1	MINDESTERFORDERNISSEN FÜR DEN AUFSTELLUNGSORT.....	DE_18
5.2	ANFORDERUNGEN AN DEN BODEN.....	DE_19
KAP. 6	TRANSPORT UND VORINSTALLATION	DE_20
KAP. 7	AUFSTELLUNG	DE_21
7.1	DÜBEL.....	DE_21
7.2	BETON	DE_21
7.3	INSTALLATIONSANWEISUNGEN	DE_22
7.4	KONTROLLE DER SPANNUNG	DE_23
7.5	NETZANSCHLUSS	DE_23
7.6	ANSCHLÜSSE.....	DE_23
7.7	KOMPLETTIERUNG UND KONTROLLE.....	DE_24
7.8	MONTAGE DER MONTAGEARME	DE_25
7.9	VERWENDUNG VON ZUBEHÖR.....	DE_25
KAP. 8	DIE BEDIENUNG DER HEBEBÜHNE	DE_26
8.1	VORSICHTSMASSNAHMEN.....	DE_26
8.2	HANDHABUNG UND VERHALTEN BEIM HEBEBÜHNEBETRIEB	DE_26
8.3	DIE STEUERUNGEN UND IHRE FUNKTIONEN.....	DE_27
8.4	UNSACHGEMÄSSE BEDIENUNG DER HEBEBÜHNE.....	DE_28
8.5	FUNKTIONSWEISE DER VORRICHTUNG DER SYNCHRONISATIONSKONTROLLE.....	DE_29
KAP. 9	SICHERHEITSEINRICHTUNGEN	DE_31
KAP. 10	WARTUNG	DE_32
10.1	WARTUNGSVORGANG.....	DE_32
10.2	SCHNECKENVERSCHLEISS UND ERSATZ DER SCHRAUBENEINHEIT	DE_34
10.3	BETRIEBSSTÖRUNGEN.....	DE_35
KAP. 11	ENTSORGUNG - VERSCHROTTUNG	DE_35
11.1	DEMONTAGE.....	DE_35
11.2	EINLAGERUNG	DE_35
11.3	ENTSORGUNG.....	DE_35
	INSTALLATIONSBERICHT	DE_36
	PERIODISCHER KUNDENBESUCH	DE_37
	AUSSERORDENTLICHE WARTUNGEN UND REPARATUREN	DE_38

ACHTUNG!

- Diese Anleitung ist ergänzender Bestandteil des Produktes und muss zusammen mit der Hebebühne sorgfältig aufbewahrt werden.
- Es ist deshalb an einem bekannten Ort und stets griffbereit aufzubewahren, um es bei Zweifeln jederzeit konsultieren zu können.
- Die Hebebühne darf ausschließlich von entsprechend geschultem Personal genutzt werden, das dieses Handbuch gelesen und verstanden hat.
- Alle Schäden, die auf Nichtbeachtung der Anweisungen dieser Anleitung oder auf einen unsachgemässen Betrieb der Hebebühne zurückzuführen sind, sind nicht dem Hersteller anzulasten und befreien die Firma ROTARY von jeglicher Haftungsspflicht.

KAP. 1 IN DER BEDIENUGSANLEITUNG VERWENDETE ZEICHEN

	Achtung!		Bedienungsanleitung/Handbuch erforderlich
	Stromschlaggefahr		Qualifiziertes Fachpersonal
	Gefahr durch hängende Lasten		Pflicht
	Gefahr durch Gabelstapler und andere Industriefahrzeuge		Nicht unter hängende Lasten durchgehen oder sich darunter aufhalten
	Gefahr durch bewegliche Teile		Schutzschuhe tragen
	Quetschgefahr für Hände		Schutzhandschuhe tragen
	Anheben von oben		Schutzkleidung tragen
	Verboten		Schutzbrille tragen
			Pflicht einer entsprechenden Trennung vor Wartungs- oder Reparaturarbeiten

KAP. 2 PRÄSENTATION

2.1 BESCHREIBUNG DER HEBEBÜHNE

- Name des Produkts: **HEBEBÜHNE FÜR PKWs**
- Beschreibung des Produkts: Elektromechanische Zweisäulenhebebühne mit Teleskoparmen.
Hebebühne zum Heben des Fahrgestells

2.2 BESTIMMUNGSGEMÄSSE VERWENDUNG

Das Produkt ist zum Heben von PKWs gemäß der geltenden Richtlinie, der Maschinenrichtlinie 2006/42/EG, bestimmt; die Tragfähigkeit entspricht den Angaben auf dem Typenschild.

Die Hebebühne wurde für den Einsatz in Innenräumen konzipiert, die keiner Einwirkung durch Wind ausgesetzt sind.

Gestattet wird das Heben von Fahrzeugen, die den folgenden Anforderungen entsprechen:

- mit einem Gewicht, das die Tragfähigkeit der Hebebühne nicht überschreitet (siehe Abb. **A**), wie von der Richtlinie UNI EN 1493:2010 vorgesehen

- Die Hebebühne erfüllt die Bedingung der Lastverteilung 2/5 - 3/5 und der Umkehrbarkeit gemäß 1493:2010 (Abb. **B**).

- Mindestabstand der Hebepunkte (Spurweite): 1000 mm (Abb. **A**)

Bei geringerem Abstand wird die Tragfähigkeit der Hebebühne reduziert. In solchen und anderen, nicht von dieser Anleitung vorgesehenen Fällen den Hersteller zu Rate ziehen.

SPMA32-X	ROT.SP32X.198549	Kg
SPMA32-XP	ROT.SP32X.198723	
SPMA32-XER	ROT.SP32X.199379	

SPMA35-X	ROT.SP35X.199263	Kg
SPMA35-XE	ROT.SP35X.198990	
SPMA35-XEV	ROT.SP35X.199416	

Abb. A

SPMA32-X	ROT.SP32X.198549
SPMA32-XP	ROT.SP32X.198723
SPMA32-XER	ROT.SP32X.199379

C mm	P1 kg	P2 kg	Q=P1+P2 kg
700	1100	1550	2650
800	1150	1650	2800
900	1200	1750	2950
1000	1280	1920	3200

25130

SPMA35-X	ROT.SP35X.199263
SPMA35-XE	ROT.SP35X.198990
SPMA35-XEV	ROT.SP35X.199416

C mm	P1 kg	P2 kg	Q=P1+P2 kg
700	1200	1700	2900
800	1250	1800	3050
900	1300	1900	3200
1000	1400	2100	3500

25030

Min. 1000 mm

Abb. B
Abb. C

KAP. 3 TECHNISCHE DATEN

3.1 TECHNISCHE HAUPTZEIGENSCHAFTEN

Verfahrbewegung der Schlitten auf Gleitschuhen aus hochfestem Technopolymer und mit niedrigem Reibungskoeffizienten. Die Hebe- und Senkbewegungen werden über tragende, aus Bronze gefertigte Schnecken umgesetzt, die mit Stellschrauben mit schmaler Gewindesteigung gekoppelt sind, um die Unumkehrbarkeit der Bewegungen zu gewährleisten. Elektronische Sicherheitsvorrichtung zum Verhindern weiterer Hubbewegungen bei vollständigem Verschleiß der tragenden Schnecke. Automatische Schmierung der Stellschrauben bei jedem Hub. Neuausrichtung der Schlitten über eine elektronische Vorrichtung. Verriegelungsvorrichtung bei einer Abweichung der Schlitten von mehr als **30 mm**.

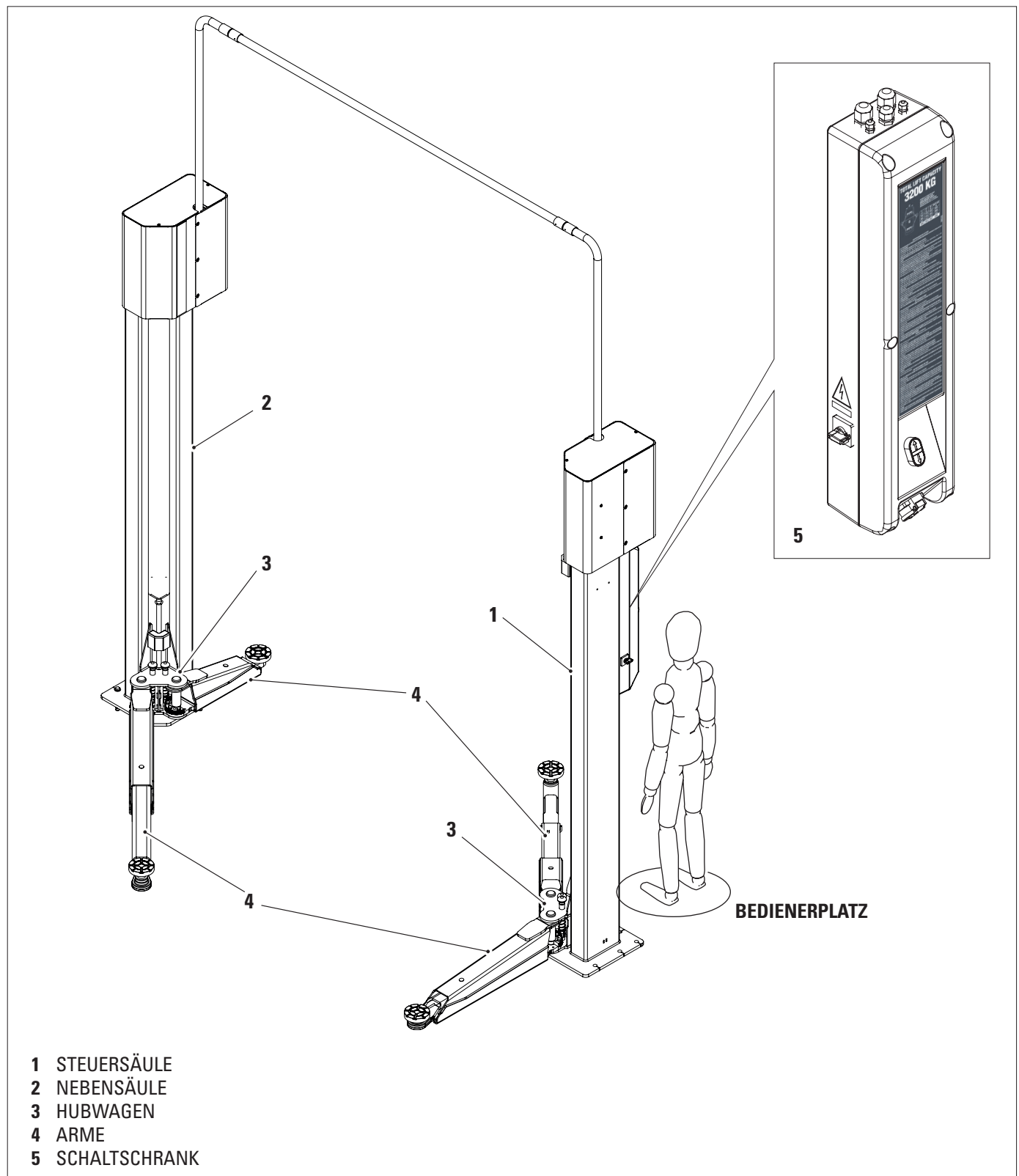

3.2 GENERAL TECHNICAL DETAILS
SPMA32

Säulenzahl	2	Vorderer Montagearm Min.	555 mm	F Mindesthöhe Stempel	96 mm
Hubkraft	3200 kg	Vorderer Montagearm Max.	1100 mm	Max. Anstiegshöhe	2000 mm
Mindesthöhe der Decke	4150 mm	Hinterer Montagearm Min.	805 mm	Anstieg	1860 mm
A Gesamthöhe	4052 mm	Hinterer Montagearm Max.	1200 mm	Zeit Anstieg/Abfahrt	42 secs.
B Außensäulen	3223 mm	E Max. Höhe Stempel	130 mm	Stromversorgung	400 V 50 Hz 3Ph
C Innensäulen	2700 mm			Antriebskraft	2x2.6 Kw
D Durchgang	2472 mm				

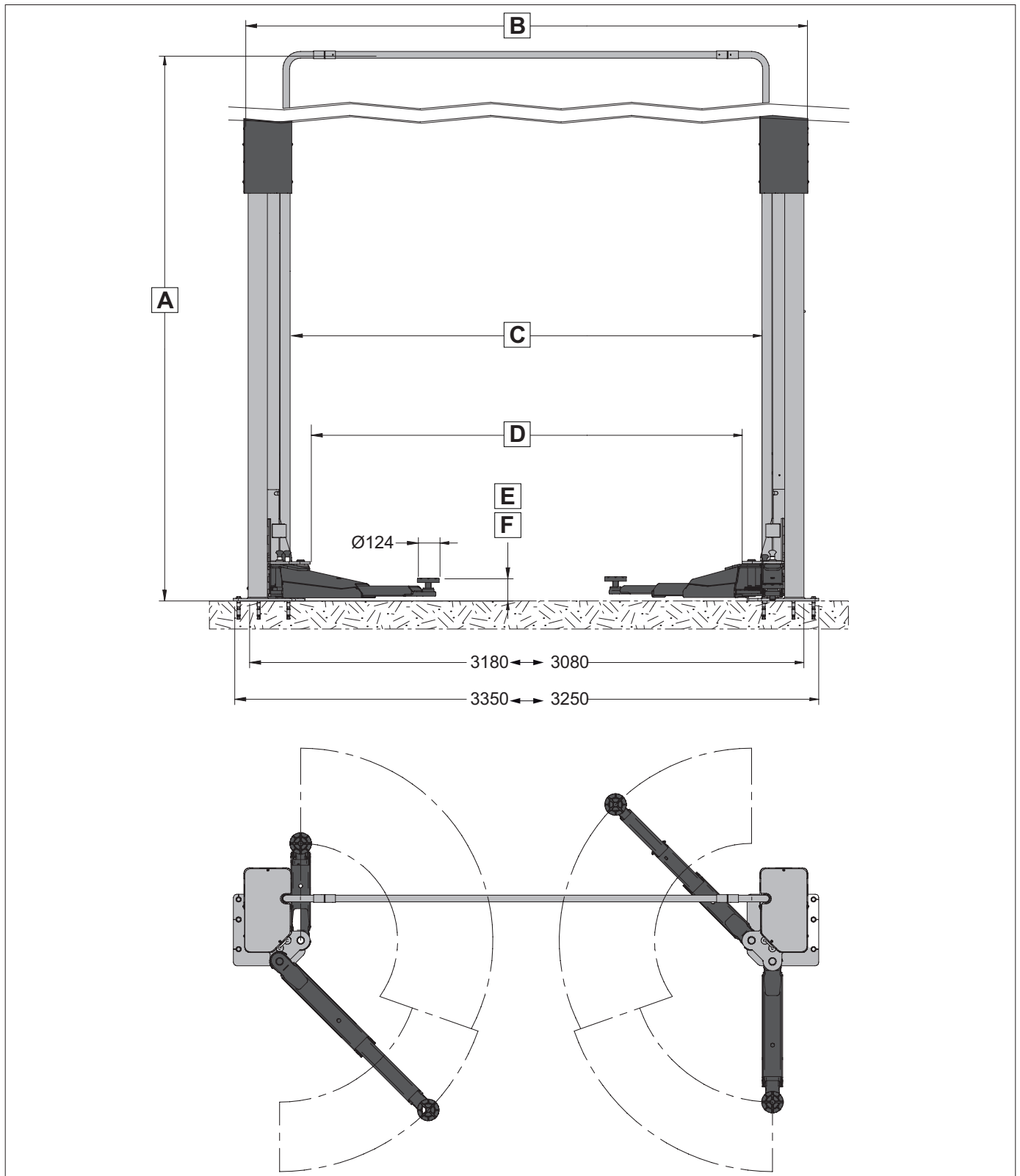

SPMA35

Säulenzahl	2	Vorderer Montagearm Min.	564 mm	E Max. Höhe Stempel	150 mm
Hubkraft	3500 kg	Vorderer Montagearm Max.	1160 mm	F Mindesthöhe Stempel	100 mm
Mindesthöhe der Decke	4150 mm	Hinterer Montagearm Min.	922 mm	Max. Anstiegshöhe	2012 mm
A Gesamthöhe	4052 mm	Hinterer Montagearm Max.	1460 mm	Anstieg	1863 mm
B Außensäulen	3223 mm			Zeit Anstieg/Abfahrt	42 secs.
C Innensäulen	2700 mm			Stromversorgung	400 V 50 Hz 3Ph
D Durchgang	2472 mm			Antriebskraft	2x2.6 Kw

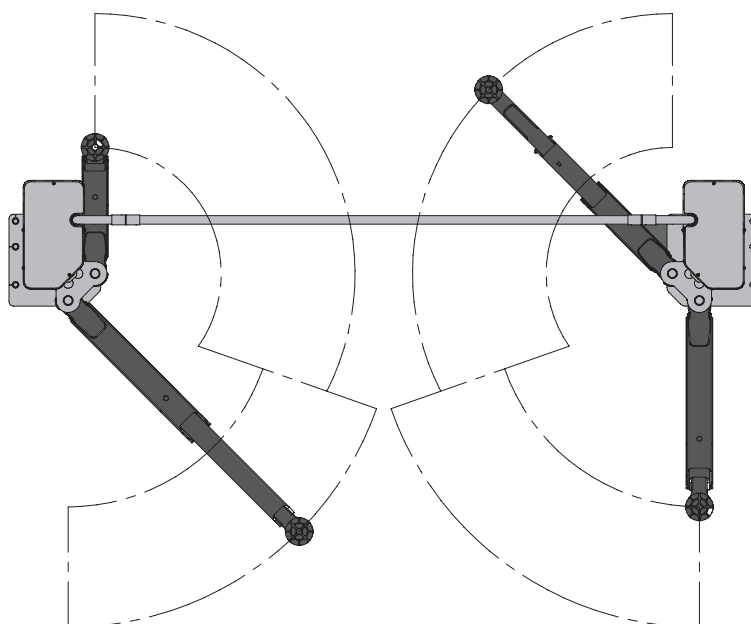
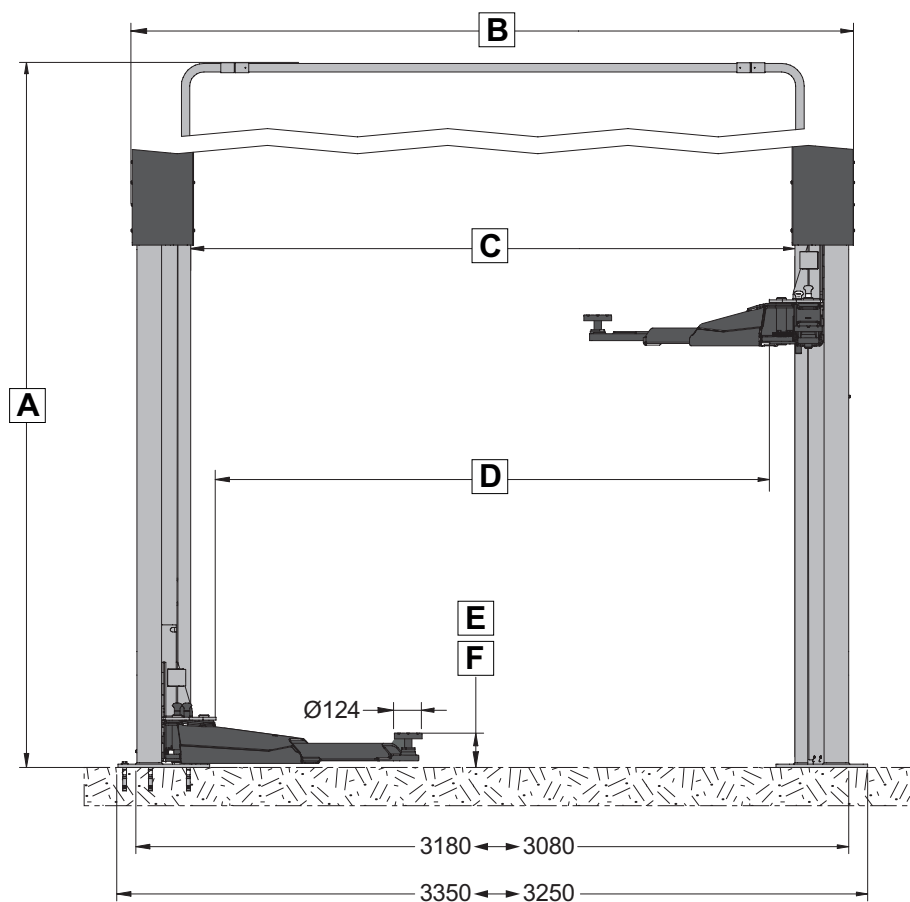

PHONOMETRISCHE DATEN
GERÄUSCHENTWICKLUNG

	Bez.	Abstand (m)	Lp dB(A)	Lpk dB(C)	U dB
	1	0,6	I 70dB(A)	I 130dB(C)	
2	1,0	73	I 130dB(C)		

3.3 KENNZEICHNUNGSDATEN DER MASCHINE

Am Schlitten der Steuersäule befindet sich das Typenschild der Hebebühne, auf dem die folgenden Daten angegeben sind:

- A** Hersteller
- B** Tragfähigkeit hebebühne
- C** Seriennummer
- D** Baujahr
- E** Modell

ACHTUNG: Es ist strengstens verboten, das Kennschild der Ausrüstung auf irgendeine Weise unbefugt zu betätigen, zu gravieren, zu verändern oder sogar abzunehmen. Das Schild nicht mit provisorischen Tafeln u.s.w. verdecken. Es muss jederzeit gut sichtbar sein.

Das Schild immer von Fett und Schmutz sauberhalten.

HINWEIS: Sollte das Schild aus zufälligen Gründen beschädigt werden (von der Ausrüstung gelöst, beschädigt oder unleserlich, auch wenn nur teilweise) den Vorfall unverzüglich dem Hersteller melden.

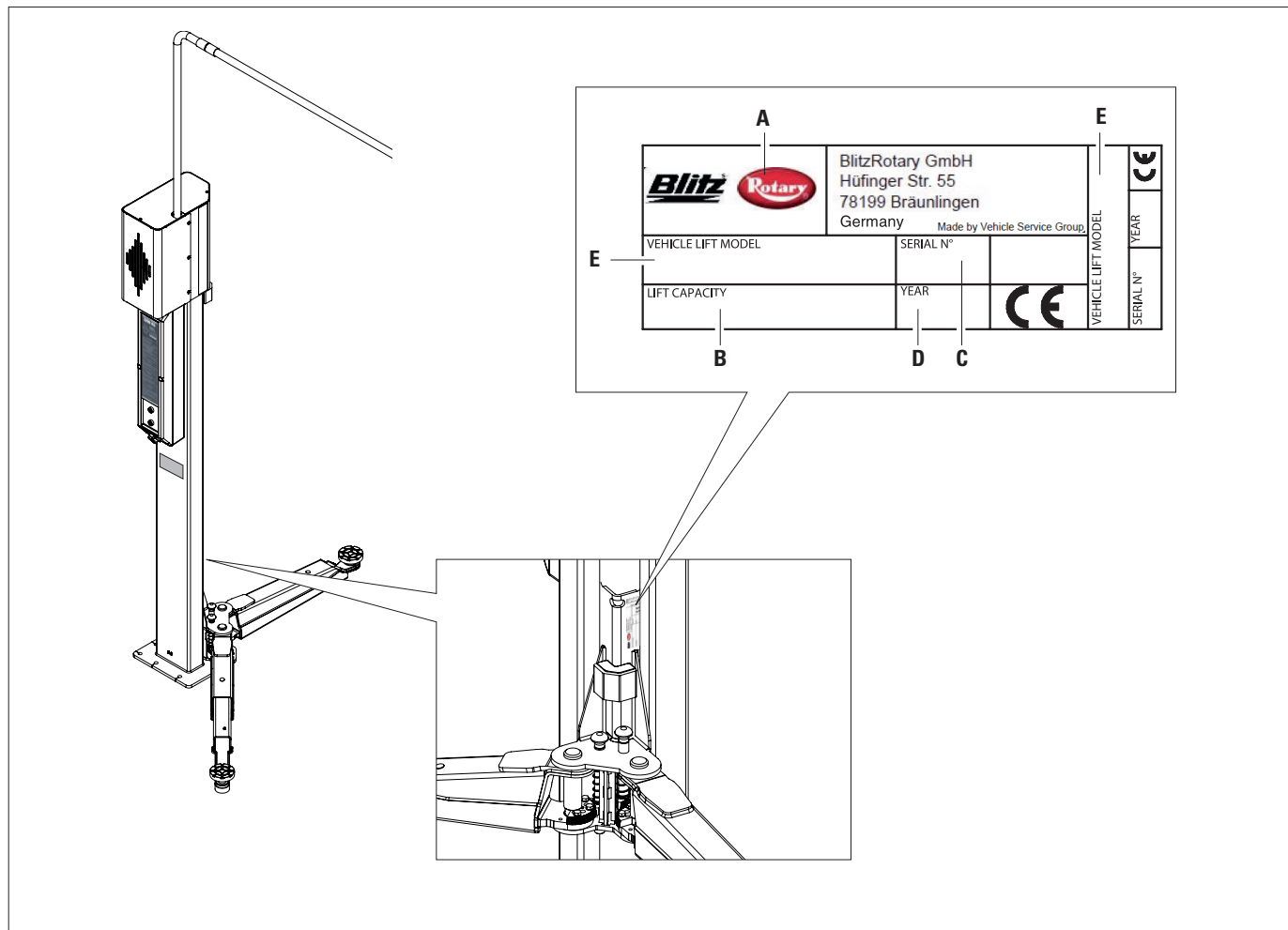

3.4 HAUPTBEDIENELEMENTE DER HEBEBÜHNE

Die Hauptbedienelemente befinden sich im Steuerkasten, der je nach Modell unterschiedlich ausfällt. Siehe Vergleichsdiagramm.

MODELL	ARTIKELNUMMER	ARTIKELNUMMER STEUERKASTEN	ARTIKELNUMMER ABZWEIGKASTEN	ARTIKELNUMMER ELEKTRISCHE ANLAGE
SPMA32-X	ROT.SP32X.198549	047303060	047303021	047305510
SPMA32-XP	ROT.SP32X.198723	047303070	047303080 (Steuerkasten)	047305530
SPMA32-XER	ROT.SP32X.199379	047303070	047303080 (Steuerkasten)	047305530
SPMA35-X	ROT.SP35X.199263	047303060	047303021	047305510
SPMA35-XE	ROT.SP35X.198990	047303070	047303080 (Steuerkasten)	047305530
SPMA35-XEV	ROT.SP35X.199416	047303070	047303080 (Steuerkasten)	047305530

047303060

Steuerkasten mit Schalter und Auf/Ab-Tasten.

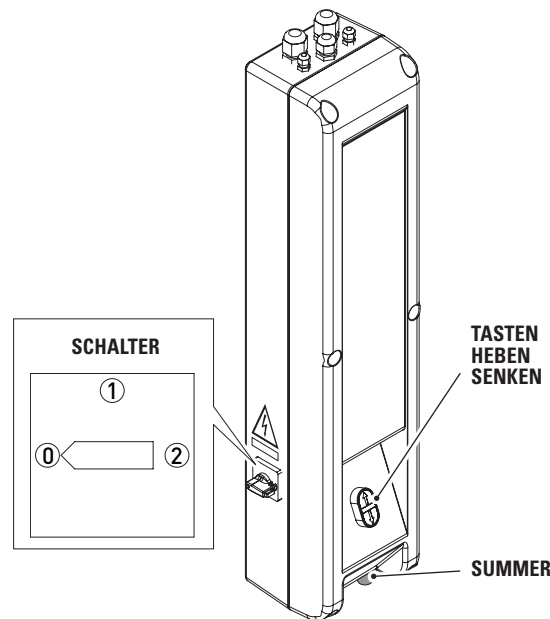
047303070 / 047303080

Doppelter Steuerkasten mit Schalter und Auf-/Ab-Tasten, Not-Aus-Taste.

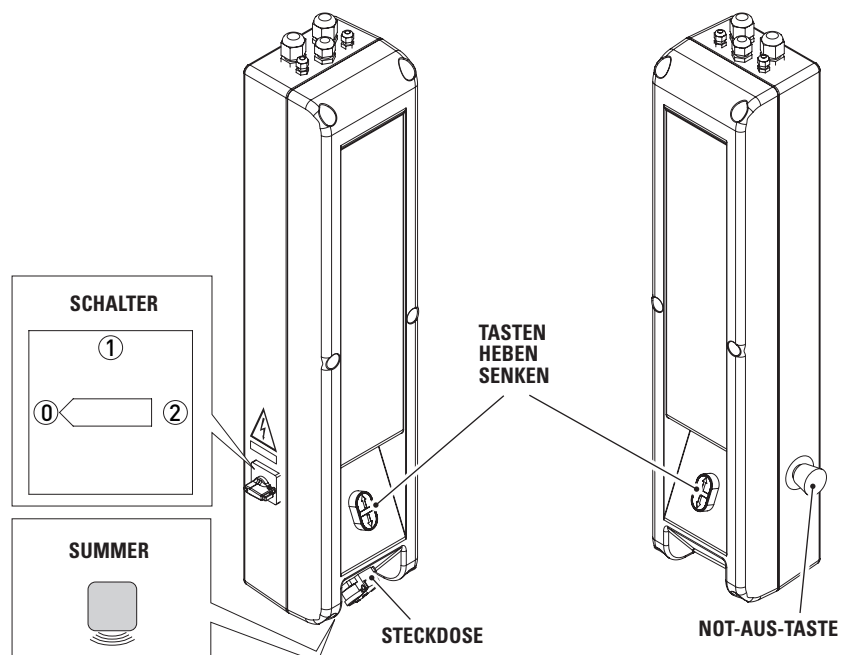

3.5. ELEKTROANLAGE

Netzanschluss nur durch Elektrofachkräfte

ARTIKELNUMMER ELEKTRISCHE ANLAGE: 047305510

Elektrische Versorgung

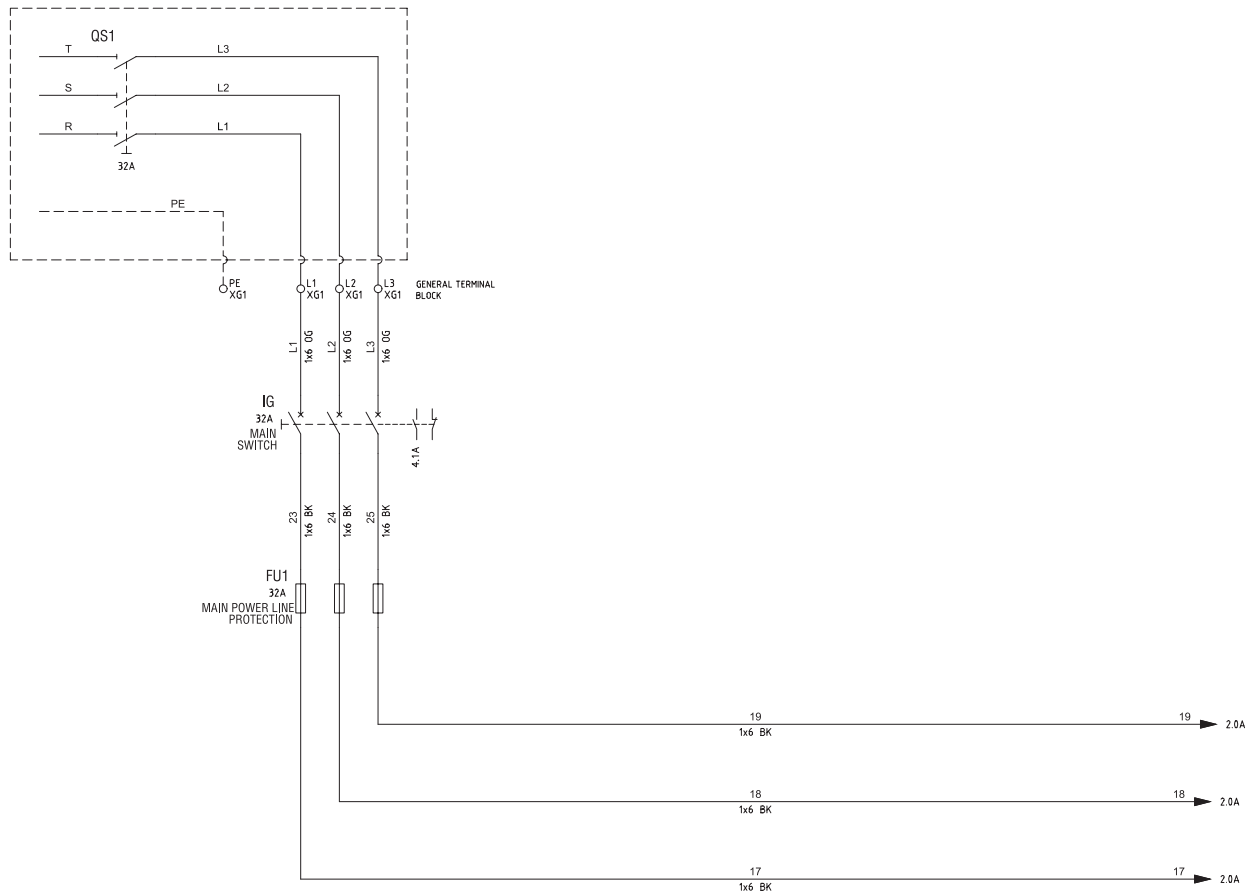

Motorversorgung

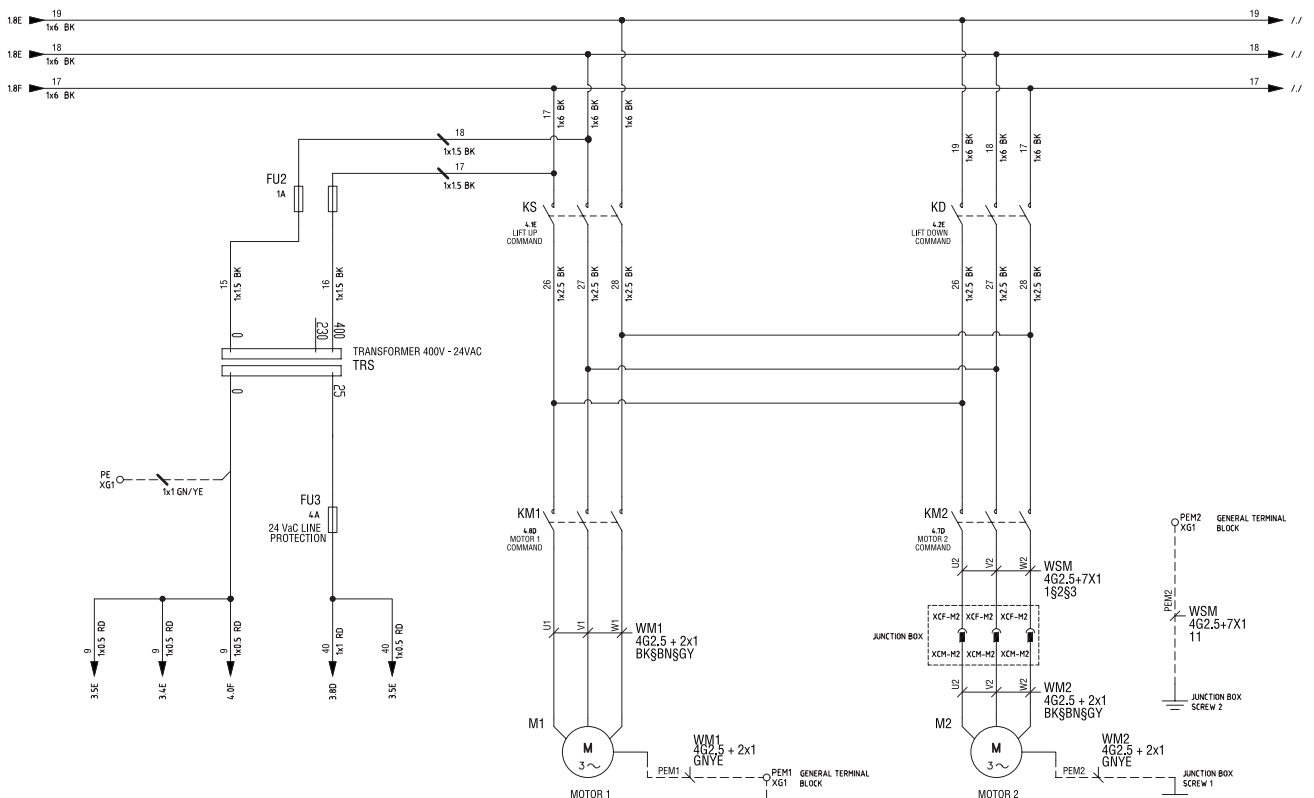

ARTIKELNUMMER ELEKTRISCHE ANLAGE: 047305510

Steuersignale

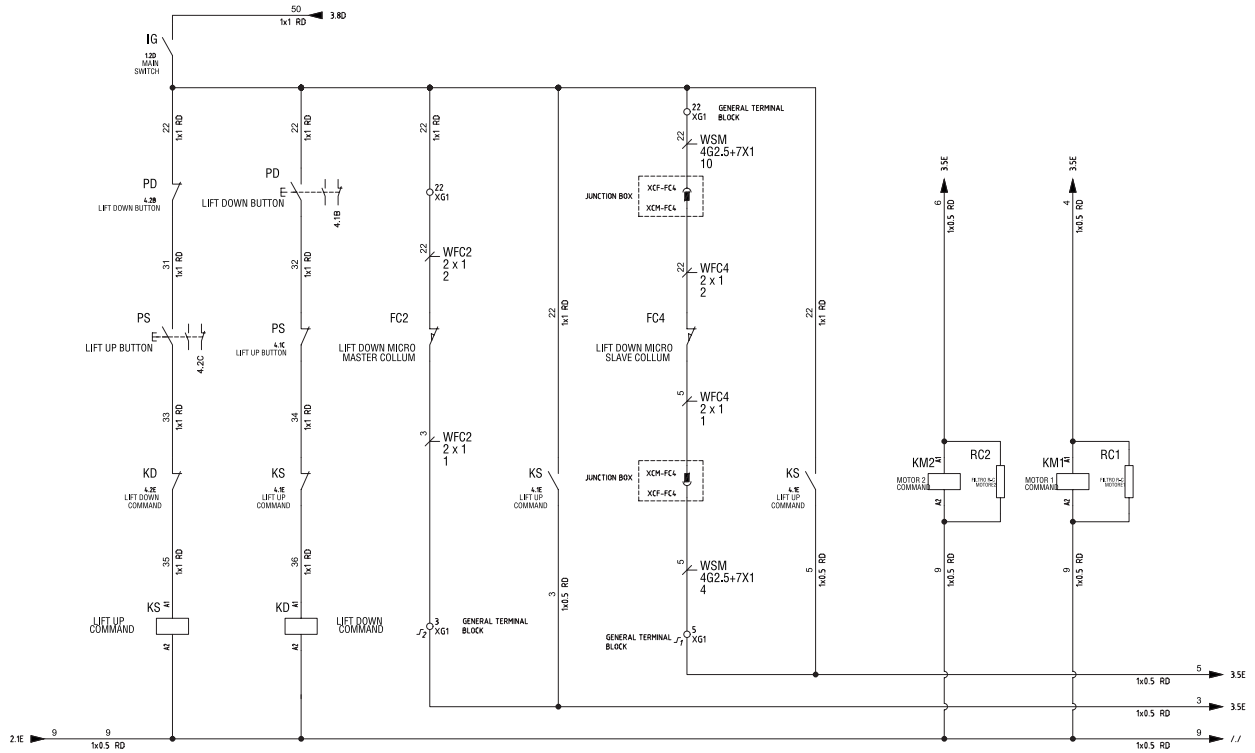

Signale

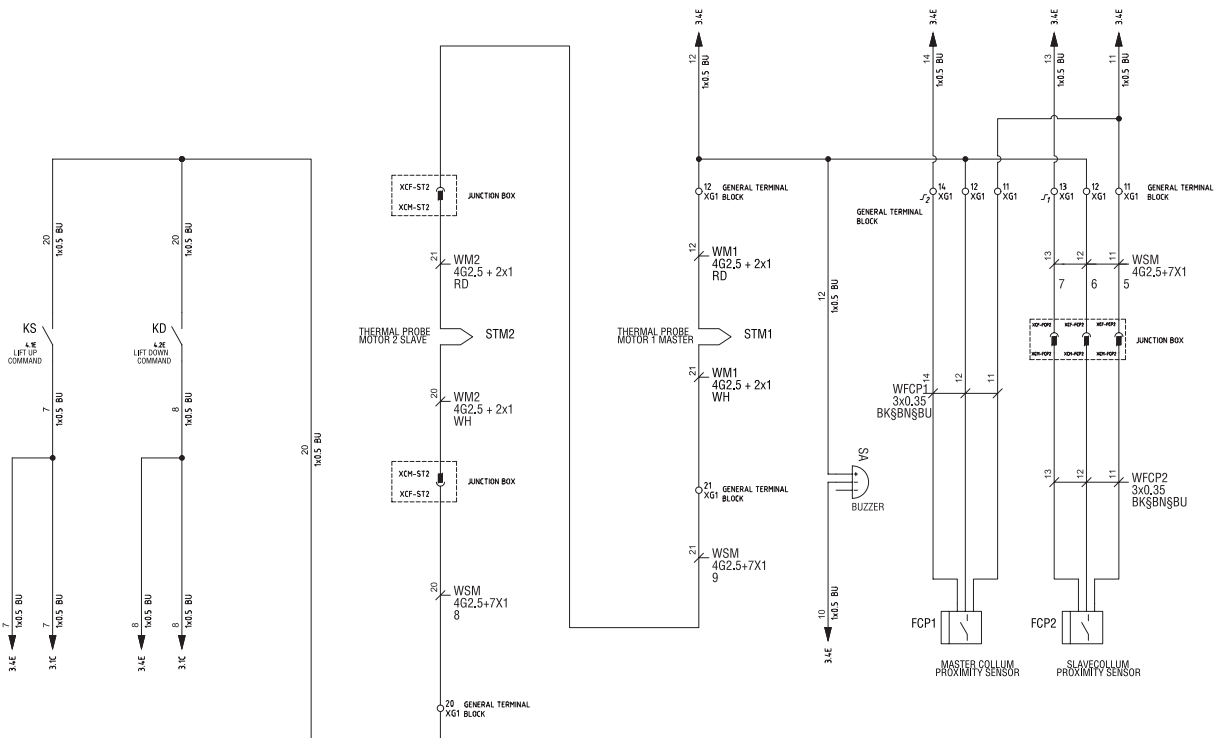

ARTIKELNUMMER ELEKTRISCHE ANLAGE: 047305510

Signale der elektronischen Platine

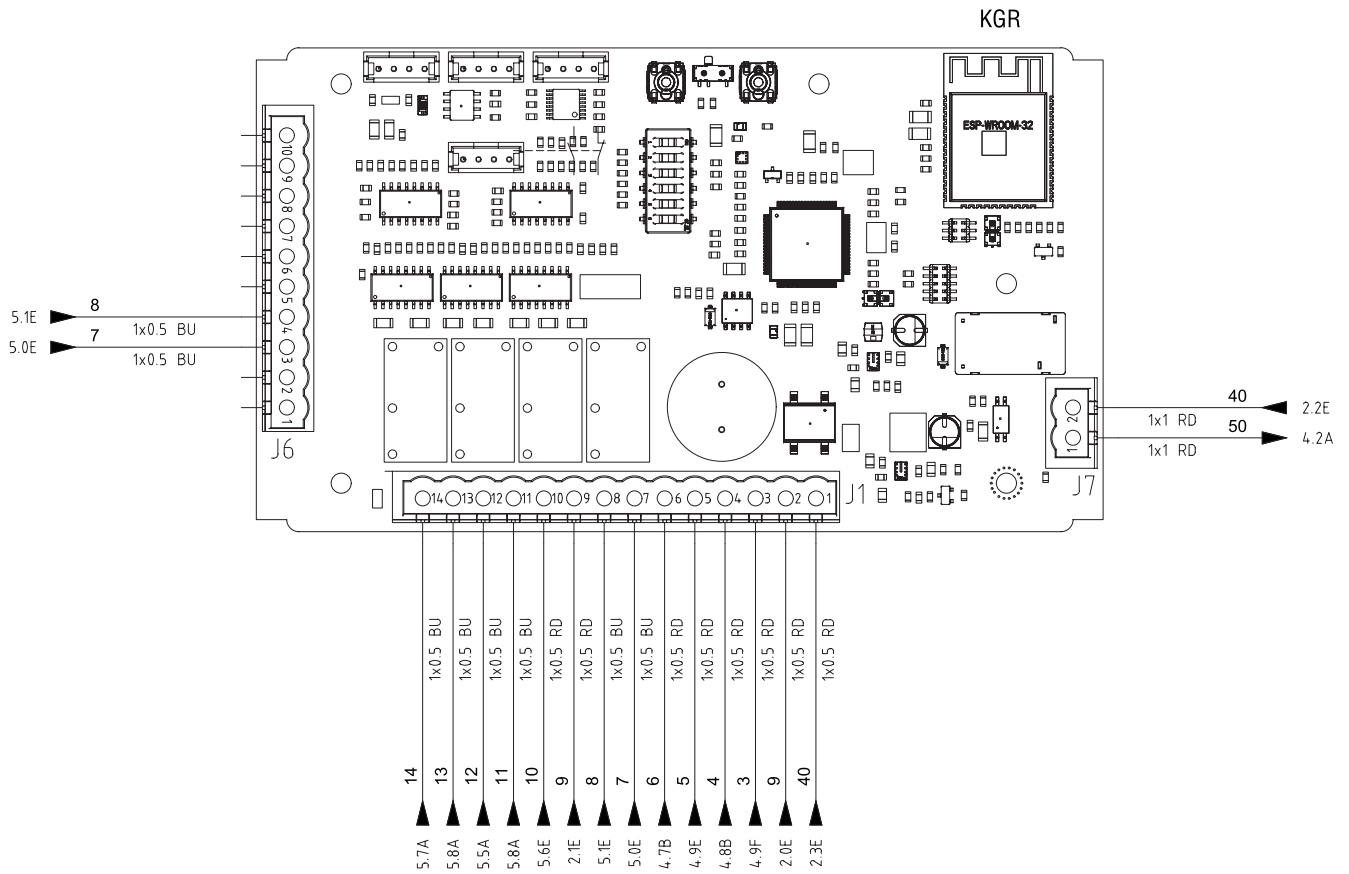

ARTIKELNUMMER ELEKTRISCHE ANLAGE: 047305510
Legende

LISTA CROSS REFERENCE \ CROSS REFERENCE LIST							
Componente	Reference	Dati Tecnici	Technical Data	Componente	Reference	Dati Tecnici	Technical Data
		Nome\Item:M1	Quadro\Panel: +BM Fg.\Sh:2			Nome\Item:FU3	Quadro\Panel: +QG Fg.\Sh:2
		Tipo \ Type :				Tipo \ Type :	
		Costruttore \ Marke :				Costruttore \ Marke :	
		Descrizione \ Device :	Motore asincrono trifase			Descrizione \ Device :	PORTAFUSIBILE UNIPOLARE 1A 5X20 250V
		Funzione \ Use Type :	MOTOR 1 COMMAND COLLUM			Funzione \ Use Type :	24 Vac LINE PROTECTION
		Nome\Item:M2	Quadro\Panel: +BM Fg.\Sh:2			Nome\Item:IG	Quadro\Panel: +QG Fg.\Sh:1
		Tipo \ Type :				Tipo \ Type :	
		Costruttore \ Marke :				Costruttore \ Marke :	
		Descrizione \ Device :	Motore asincrono trifase			Descrizione \ Device :	INTERRUTTORE GENERALE 4 POLI + AUX, 32A
		Funzione \ Use Type :	MOTOR 2 SLAVE COLLUM			Funzione \ Use Type :	MAIN SWITCH
		Nome\Item:FC2	Quadro\Panel: +BM Fg.\Sh:4			Nome\Item:KD	Quadro\Board: +QG Fg.\Sh:4
		Tipo \ Type :				Tipo \ Type :	
		Costruttore \ Marke :				Costruttore \ Marke :	
		Descrizione \ Device :	Fine corsa NC			Descrizione \ Device :	TELERUTTORE COMADO DISCESA
		Funzione \ Use Type :	LIFT DOWN MICRO MASTER COLLUM			Funzione \ Use Type :	LIFT DOWN COMMAND
		Nome\Item:FC4	Quadro\Panel: +BM Fg.\Sh:4			Nome\Item:KM1	Quadro\Panel: +QG Fg.\Sh:4
		Tipo \ Type :				Tipo \ Type :	
		Costruttore \ Marke :				Costruttore \ Marke :	
		Descrizione \ Device :	Fine corsa NC			Descrizione \ Device :	TELERUTTORE COMANDO MOTORE 1
		Funzione \ Use Type :	LIFT DOWN MICRO SLAVE COLLUM			Funzione \ Use Type :	MOTOR 1 COMMAND
		Nome\Item:FU1	Quadro\Panel: +QG Fg.\Sh:1			Nome\Item:KM2	Quadro\Panel: +QG Fg.\Sh:4
		Tipo \ Type :				Tipo \ Type :	
		Costruttore \ Marke :				Costruttore \ Marke :	
		Descrizione \ Device :	PORTAFUS, TRIPOLARE 10X38 WIMEX 32A 500V			Descrizione \ Device :	TELERUTTORE COMANDO MOTORE 2
		Funzione \ Use Type :	MAIN POWER LINE PROTECTION			Funzione \ Use Type :	MOTOR 2 COMMAND
		Nome\Item:FU2	Quadro\Panel: +QG Fg.\Sh:2			Nome\Item:KS	Quadro\Panel: +QG Fg.\Sh:4
		Tipo \ Type :				Tipo \ Type :	
		Costruttore \ Marke :				Costruttore \ Marke :	
		Descrizione \ Device :	PORTAFUS, BIPOLARE 10X38 WIMEX 1A 500V			Descrizione \ Device :	TELERUTTORE COMANDO SALITA
		Funzione \ Use Type :	TRANSFORMER POWER LINE PROTECTION			Funzione \ Use Type :	LIFT UP COMMAND

LISTA CROSS REFERENCE \ CROSS REFERENCE LIST							
Componente	Reference	Dati Tecnici	Technical Data	Componente	Reference	Dati Tecnici	Technical Data
		Nome\Item:PD	Quadro\Panel: +QG Fg.\Sh:4			Nome\Item:FCP1	Quadro\Panel: +BM Fg.\Sh:5
		Tipo \ Type :				Tipo \ Type :	
		Costruttore \ Marke :				Costruttore \ Marke :	
		Descrizione \ Device :	PULSANTE DISCESA			Descrizione \ Device :	INTERRUTTORE DI PROSSIMITA'
		Funzione \ Use Type :	LIFT DOWN BUTTON			Funzione \ Use Type :	PROXIMITY SENSOR
		Nome\Item:PS	Quadro\Panel: +QG Fg.\Sh:4			Nome\Item:FCP2	Quadro\Panel: +BM Fg.\Sh:5
		Tipo \ Type :				Tipo \ Type :	
		Costruttore \ Marke :				Costruttore \ Marke :	
		Descrizione \ Device :	PULSANTE DISCESA			Descrizione \ Device :	INTERRUTTORE DI PROSSIMITA'
		Funzione \ Use Type :	LIFT UP BUTTON			Funzione \ Use Type :	PROXIMITY SENSOR
		Nome\Item:QS1	Quadro\Panel: +QG Fg.\Sh:1			Nome\Item:KGR	Quadro\Board: +QG Fg.\Sh:3
		Tipo \ Type :				Tipo \ Type :	
		Costruttore \ Marke :				Costruttore \ Marke :	
		Descrizione \ Device :	INTERRUTTORE GENERALE CLIENTE 32A			Descrizione \ Device :	SCHEDA ELETTRONICA
		Funzione \ Use Type :	CLIENT POWER MAIN SWITCH			Funzione \ Use Type :	ELECTRONIC BOARD
		Nome\Item:RC1	Quadro\Panel: +QG Fg.\Sh:4			Nome\Item:STM1	Quadro\Panel: +BM Fg.\Sh:5
		Tipo \ Type :				Tipo \ Type :	
		Costruttore \ Marke :				Costruttore \ Marke :	
		Descrizione \ Device :	FILTRO ANTIDISTURBI R-C			Descrizione \ Device :	SONDA TERMICA
		Funzione \ Use Type :	FILTRO R-C MOTORE1			Funzione \ Use Type :	THERMAL PROBE MOTOR 1 MASTER
		Nome\Item:RC2	Quadro\Panel: +QG Fg.\Sh:4			Nome\Item:STM2	Quadro\Panel: +BM Fg.\Sh:5
		Tipo \ Type :				Tipo \ Type :	
		Costruttore \ Marke :				Costruttore \ Marke :	
		Descrizione \ Device :	FILTRO ANTIDISTURBI R-C			Descrizione \ Device :	SONDA TERMICA
		Funzione \ Use Type :	FILTRO R-C MOTORE2			Funzione \ Use Type :	THERMAL PROBE MOTOR 2 SLAVE
		Nome\Item:SA	Quadro\Panel: +QG Fg.\Sh:5			Nome\Item:TRS	Quadro\Panel: +QG Fg.\Sh:2
		Tipo \ Type :				Tipo \ Type :	
		Costruttore \ Marke :				Costruttore \ Marke :	
		Descrizione \ Device :	AVVISATORE ACUSTICO			Descrizione \ Device :	TRASFORMATORE 100 V/A
		Funzione \ Use Type :	BUZZER			Funzione \ Use Type :	TRANSFORMER 400V - 24VAC

ARTIKELNUMMER ELEKTRISCHE ANLAGE: 047305530

Elektrische Versorgung

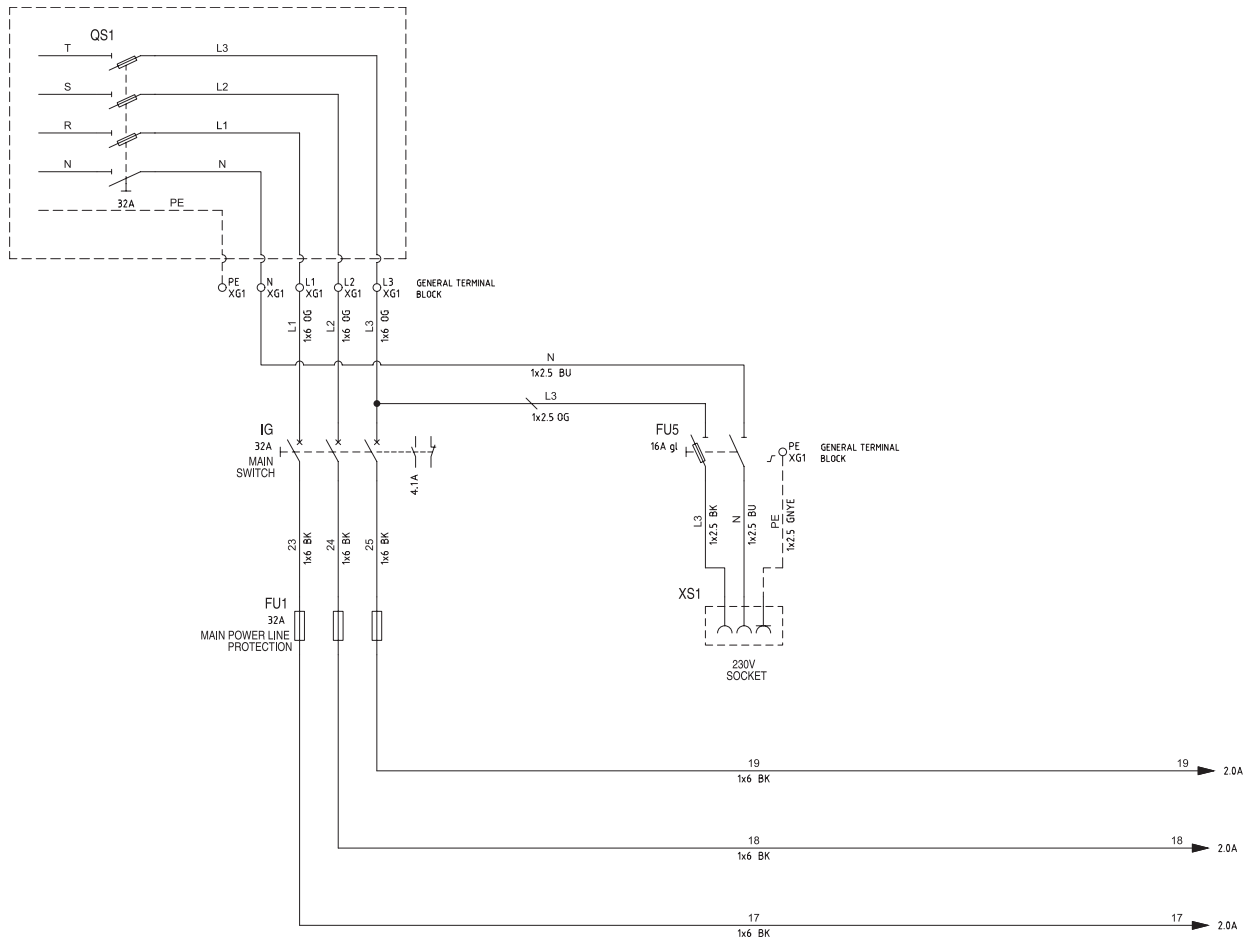

Motorversorgung

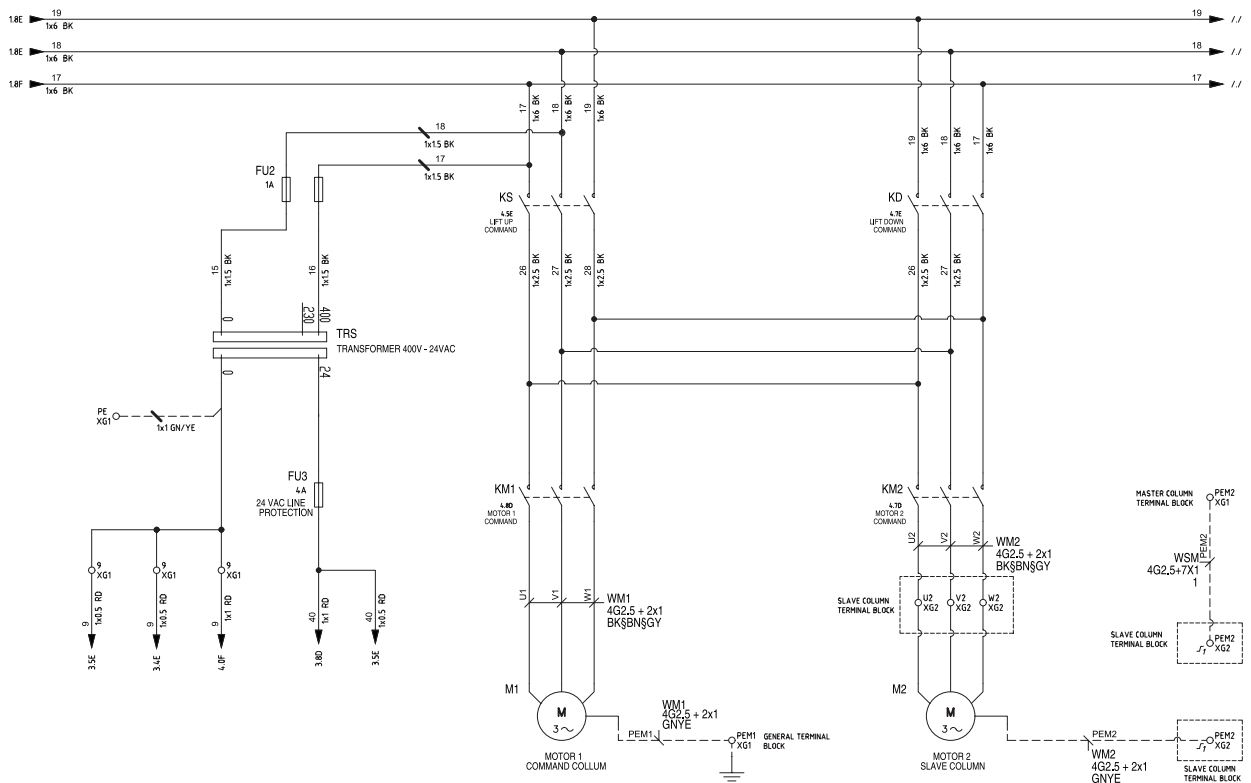

ARTIKELNUMMER ELEKTRISCHE ANLAGE: 047305530

Signale der elektronischen Platine

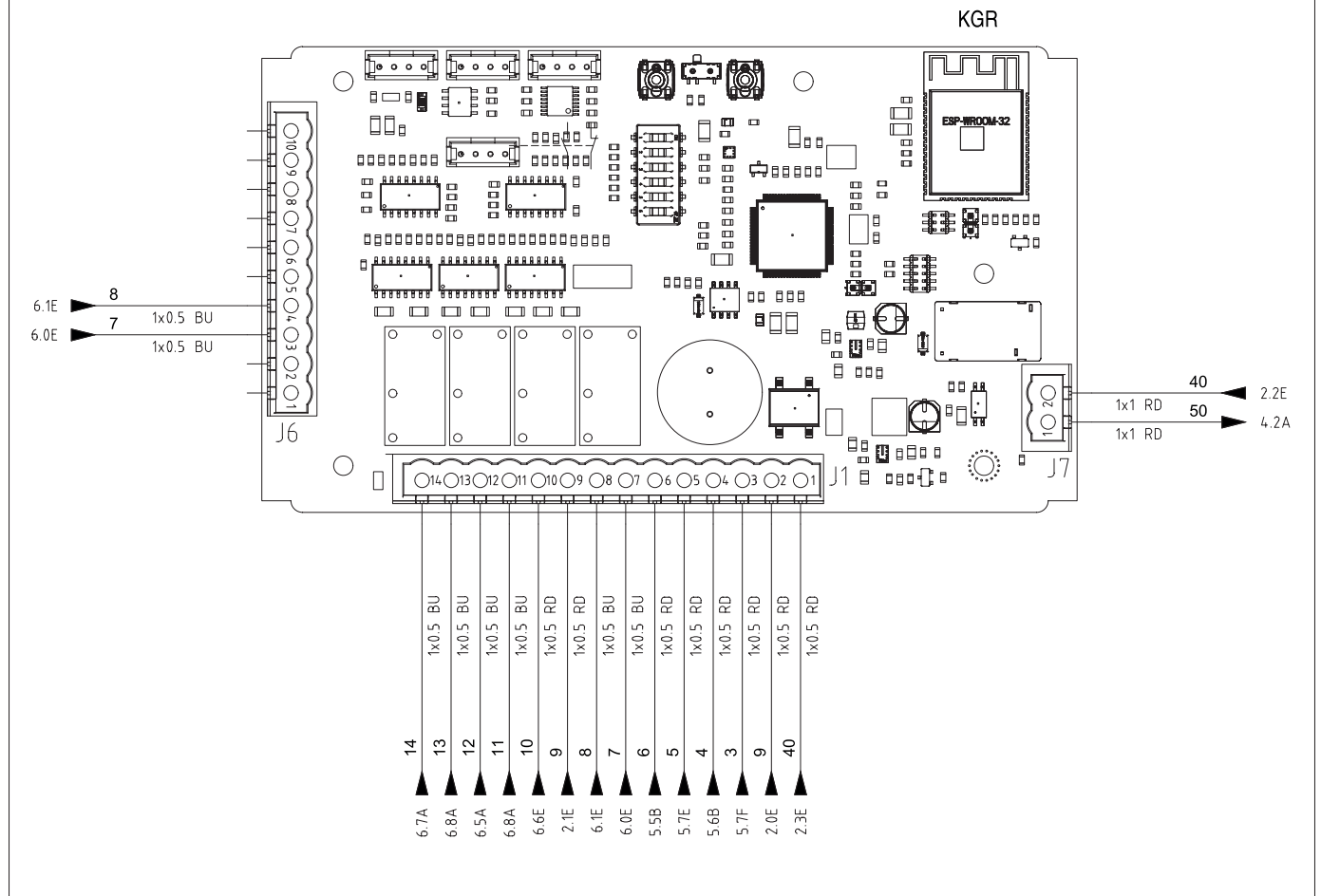

Steuersignale

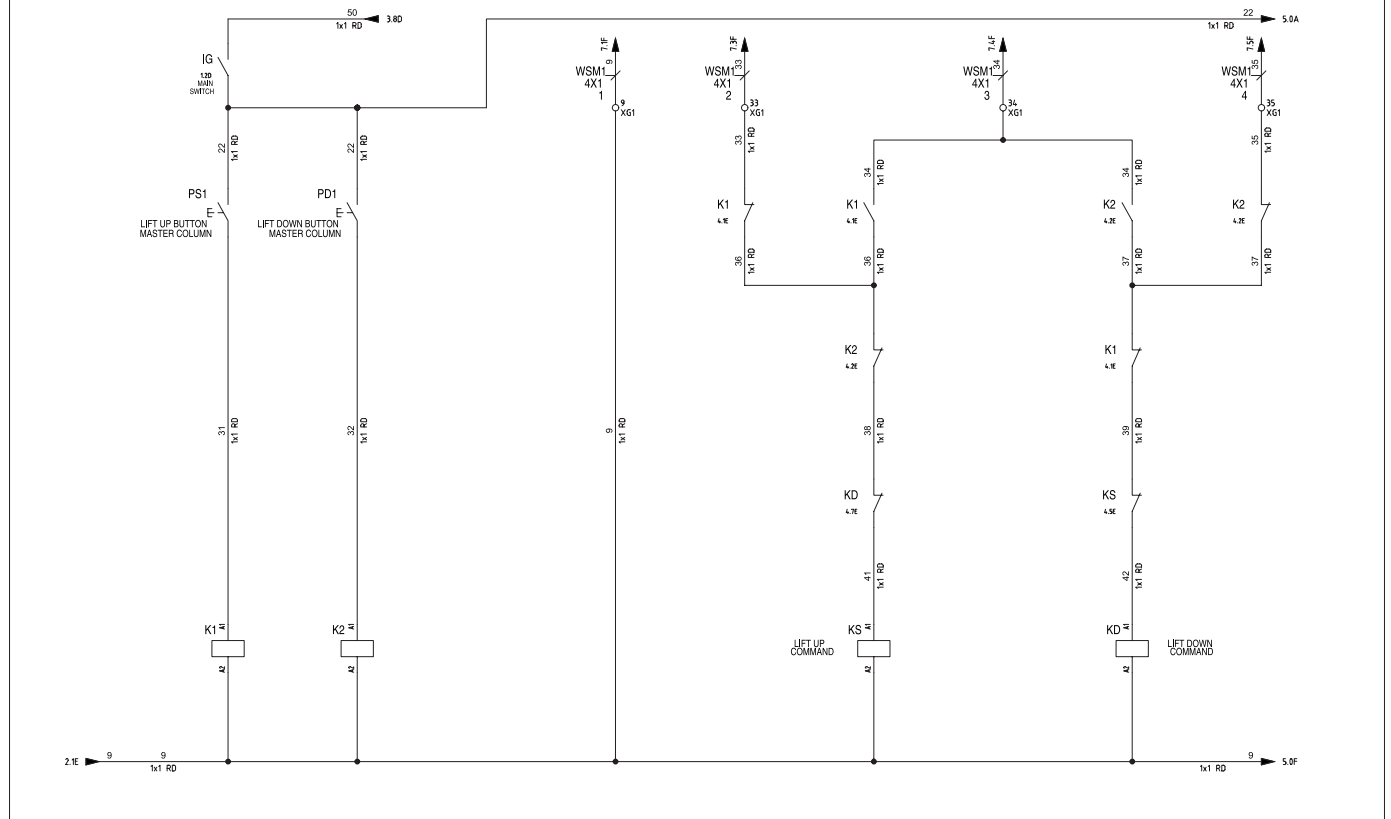

ARTIKELNUMMER ELEKTRISCHE ANLAGE: 047305530

Signale

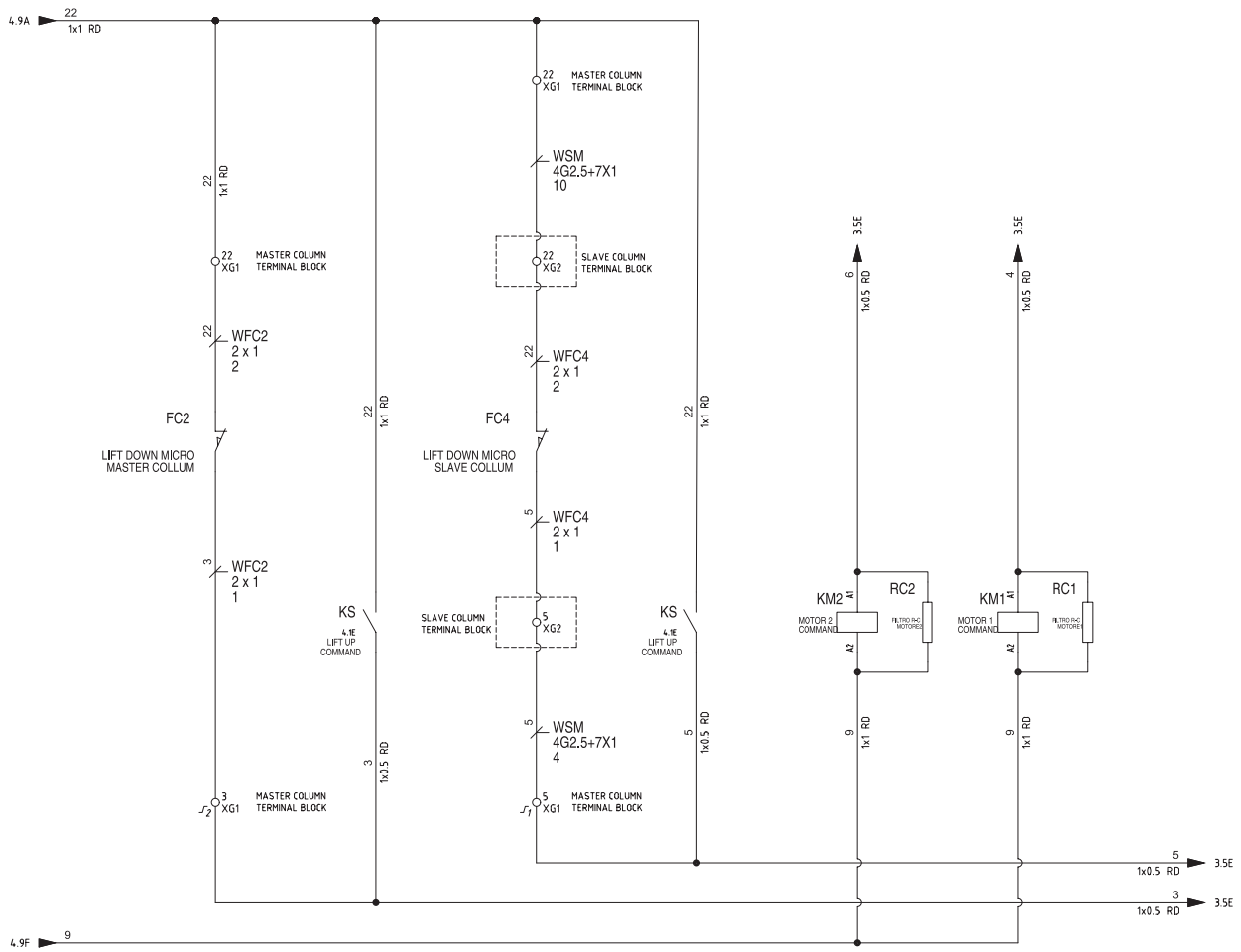

Signale

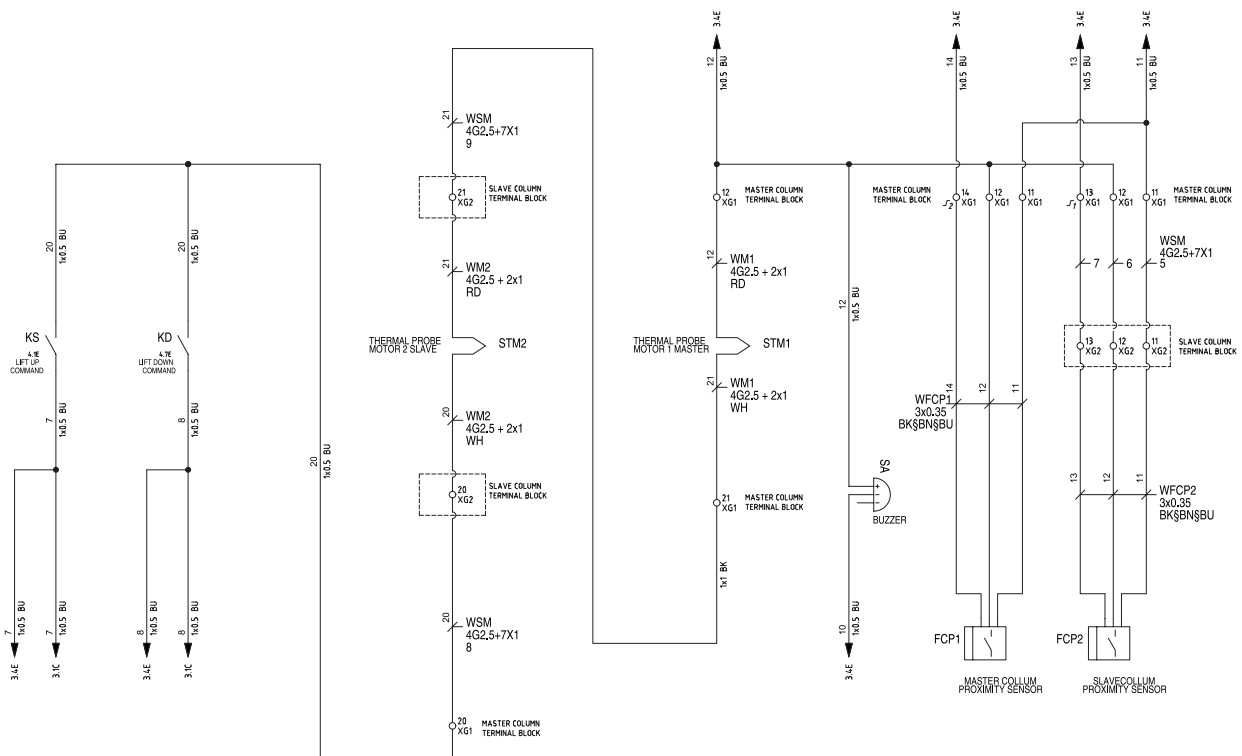

ARTIKELNUMMER ELEKTRISCHE ANLAGE: 047305530
Legende

LISTA CROSS REFERENCE \ CROSS REFERENCE LIST							
Componente	Reference	Dati Tecnici	Technical Data	Componente	Reference	Dati Tecnici	Technical Data
		Nome\Item:M1	Quadro\Panel: +BM Fg.\Sh.:2			Nome\Item:FU3	Quadro\Panel: +QG Fg.\Sh.:2
		Tipo \ Type : Costruttore \ Marke: Descrizione \ Device : Motore asincrono trifase Funzione \ Use Type : MOTOR 1 COMMAND COLLUM				Tipo \ Type : Costruttore \ Marke: Descrizione \ Device : PORTAFUSIBILE UNIPOLARE 1A 5X20 250V Funzione \ Use Type : 24 VaC LINE PROTECTION	
		Nome\Item:M2	Quadro\Panel: +BM Fg.\Sh.:2			Nome\Item:IG	Quadro\Panel: +QG Fg.\Sh.:1
		Tipo \ Type : Costruttore \ Marke: Descrizione \ Device : Motore asincrono trifase Funzione \ Use Type : MOTOR 2 SLAVE COLUMN				Tipo \ Type : Costruttore \ Marke: Descrizione \ Device : INTERRUTTORE GENERALE 4 POLI + AUX. 32A Funzione \ Use Type : MAIN SWITCH	
		Nome\Item:FC2	Quadro\Panel: +BM Fg.\Sh.:4			Nome\Item:KD	Quadro\Board: +QG Fg.\Sh.:4
		Tipo \ Type : Costruttore \ Marke: Descrizione \ Device : Fine corsa NC Funzione \ Use Type : LIFT DOWN MICRO MASTER COLLUM				Tipo \ Type : Costruttore \ Marke: Descrizione \ Device : TELERUTTORE COMADO DISCESA Funzione \ Use Type : LIFT DOWN COMMAND	
		Nome\Item:FC4	Quadro\Panel: +BM Fg.\Sh.:4			Nome\Item:KM1	Quadro\Panel: +QG Fg.\Sh.:4
		Tipo \ Type : Costruttore \ Marke: Descrizione \ Device : Fine corsa NC Funzione \ Use Type : LIFT DOWN MICRO SLAVE COLLUM				Tipo \ Type : Costruttore \ Marke: Descrizione \ Device : TELERUTTORE COMANDO MOTORE 1 Funzione \ Use Type : MOTOR 1 COMMAND	
		Nome\Item:FU1	Quadro\Panel: +QG Fg.\Sh.:1			Nome\Item:KM2	Quadro\Panel: +QG Fg.\Sh.:4
		Tipo \ Type : Costruttore \ Marke: Descrizione \ Device : PORTAFUS. TRIPOLARE 10X38 WIMEX 32A 500V Funzione \ Use Type : MAIN POWER LINE PROTECTION				Tipo \ Type : Costruttore \ Marke: Descrizione \ Device : TELERUTTORE COMANDO MOTORE 2 Funzione \ Use Type : MOTOR 2 COMMAND	
		Nome\Item:FU2	Quadro\Panel: +QG Fg.\Sh.:2			Nome\Item:KS	Quadro\Panel: +QG Fg.\Sh.:4
		Tipo \ Type : Costruttore \ Marke: Descrizione \ Device : PORTAFUS. BIPOLARE 10X38 WIMEX 1A 500V Funzione \ Use Type : TRANSFORMER POWER LINE PROTECTION				Tipo \ Type : Costruttore \ Marke: Descrizione \ Device : TELERUTTORE COMANDO SALITA Funzione \ Use Type : LIFT UP COMMAND	

LISTA CROSS REFERENCE \ CROSS REFERENCE LIST							
Componente	Reference	Dati Tecnici	Technical Data	Componente	Reference	Dati Tecnici	Technical Data
		Nome\Item:PD	Quadro\Panel: +QG Fg.\Sh.:4			Nome\Item:FCP1	Quadro\Panel: +BM Fg.\Sh.:5
		Tipo \ Type : Costruttore \ Marke: Descrizione \ Device : PULSANTE DISCESA Funzione \ Use Type : LIFT DOWN BUTTON				Tipo \ Type : Costruttore \ Marke: Descrizione \ Device : INTERRUTTORE DI PROSSIMITA' Funzione \ Use Type : PROXIMITY SENSOR	
		Nome\Item:PS	Quadro\Panel: +QG Fg.\Sh.:4			Nome\Item:FCP2	Quadro\Panel: +BM Fg.\Sh.:5
		Tipo \ Type : Costruttore \ Marke: Descrizione \ Device : PULSANTE DISCESA Funzione \ Use Type : LIFT UP BUTTON				Tipo \ Type : Costruttore \ Marke: Descrizione \ Device : INTERRUTTORE DI PROSSIMITA' Funzione \ Use Type : PROXIMITY SENSOR	
		Nome\Item:QS1	Quadro\Panel: +QG Fg.\Sh.:1			Nome\Item:KGR	Quadro\Board: +QG Fg.\Sh.:3
		Tipo \ Type : Costruttore \ Marke: Descrizione \ Device : INTERRUTTORE GENERALE CLIENTE 32A Funzione \ Use Type : CLIENT POWER MAIN SWITCH				Tipo \ Type : Costruttore \ Marke: Descrizione \ Device : SCHEDA ELETTRONICA Funzione \ Use Type : ELECTRONIC BOARD	
		Nome\Item:RC1	Quadro\Panel: +QG Fg.\Sh.:4			Nome\Item:STM1	Quadro\Panel: +BM Fg.\Sh.:5
		Tipo \ Type : Costruttore \ Marke: Descrizione \ Device : FILTRO ANTIDISTURBI R-C Funzione \ Use Type : FILTRO R-C MOTORE1				Tipo \ Type : Costruttore \ Marke: Descrizione \ Device : SONDA TERMICA Funzione \ Use Type : THERMAL PROBE MOTOR 1 MASTER	
		Nome\Item:RC2	Quadro\Panel: +QG Fg.\Sh.:4			Nome\Item:STM2	Quadro\Panel: +BM Fg.\Sh.:5
		Tipo \ Type : Costruttore \ Marke: Descrizione \ Device : FILTRO ANTIDISTURBI R-C Funzione \ Use Type : FILTRO R-C MOTORE2				Tipo \ Type : Costruttore \ Marke: Descrizione \ Device : SONDA TERMICA Funzione \ Use Type : THERMAL PROBE MOTOR 2 SLAVE	
		Nome\Item:SA	Quadro\Panel: +QG Fg.\Sh.:5			Nome\Item:TRS	Quadro\Panel: +QG Fg.\Sh.:2
		Tipo \ Type : Costruttore \ Marke: Descrizione \ Device : AVVISATORE ACUSTICO Funzione \ Use Type : BUZZER				Tipo \ Type : Costruttore \ Marke: Descrizione \ Device : TRASFORMATORE 100 V/A Funzione \ Use Type : TRANSFORMER 400V - 24VAC	
		Nome\Item: FU5	Quadro\Panel: +QG Fg.\Sh.:1			Nome\Item:	Quadro\Panel: Fg.\Sh.:
		Tipo \ Type : Costruttore \ Marke: Descrizione \ Device : Funzione \ Use Type : PROTEZIONE LINA 230V PRESA				Tipo \ Type : Costruttore \ Marke: Descrizione \ Device : Funzione \ Use Type :	
		Nome\Item: XS1	Quadro\Panel: +QG Fg.\Sh.:1			Nome\Item:	Quadro\Panel: Fg.\Sh.:
		Tipo \ Type : Costruttore \ Marke: Descrizione \ Device : PRESA 230V Funzione \ Use Type :				Tipo \ Type : Costruttore \ Marke: Descrizione \ Device : Funzione \ Use Type :	

KAP. 4 ALLGEMEINE SICHERHEITSVORSCHRIFTEN

4.1 HINWEISE ZU DEN RESTRISIKEN

Bei der Entwicklung unserer Hebebühne wurden strenge Normen zur Übereinstimmung mit den in den einschlägigen Richtlinien vorgeschriebenen Anforderungen angewandt.

Die Analyse der Risiken wurde mit grösster Sorgfalt ausgeführt und die Gefährdungen wurden, soweit möglich, beseitigt. Eventuelle Restrisiken werden in dieser Bedienungsanleitung und auf den Gefahrenzeichen auf der Ausrüstung angezeigt.

4.2 SICHERHEITSSCHILDER UND/ODER -AUFKLEBER

An der Hebebühne befinden sich Schilder und Aufkleber zur Kennzeichnung der Maschine, mit Angabe ihrer Tragfähigkeit, mit Anweisungen und zur Kennzeichnung der elektrischen Anlage.

Evtl. beschädigte Gefahrenzeichen sind bei der ROTARY anzufordern und zu ersetzen.

4.3 SCHULUNG DES BEDIENUNGSPERSONALS

Die Einrichtung darf nur von entsprechend geschultem und autorisiertem Personal benutzt werden.

Um den einwandfreien Betrieb der Hebebühne und die effiziente und sichere Ausführung der Arbeiten zu gewährleisten, muss das verantwortliche Personal fachgerecht geschult werden, um die notwendigen Kenntnisse für das vorschriftsmässige Arbeiten nach den Herstelleranweisungen zu erwerben.

Sollten hinsichtlich Installation, Gebrauch und Wartung der Hebebühne Zweifel auftreten, in der Bedienungsanleitung nachlesen oder sich ggf. an die autorisierten Servicestellen oder an den technischen Kundendienst der Firma ROTARY wenden.

4.4 BETRIEBSTÜCHTIGKEIT

Dieses Produkt ist gemäss der Europäischen Richtlinie 2006/42/CE gebaut worden. Kraft des Artikels 4.1.2.3 (Anlage 1) der o.g. Richtlinie sind für die Prüfungen folgende Koeffizienten angewandt worden:

1.10 für die dynamische Prüfung

1.25 für die statische Prüfung

Diese Prüfungen sind durch spezialisiertes Fachpersonal auszuführen.

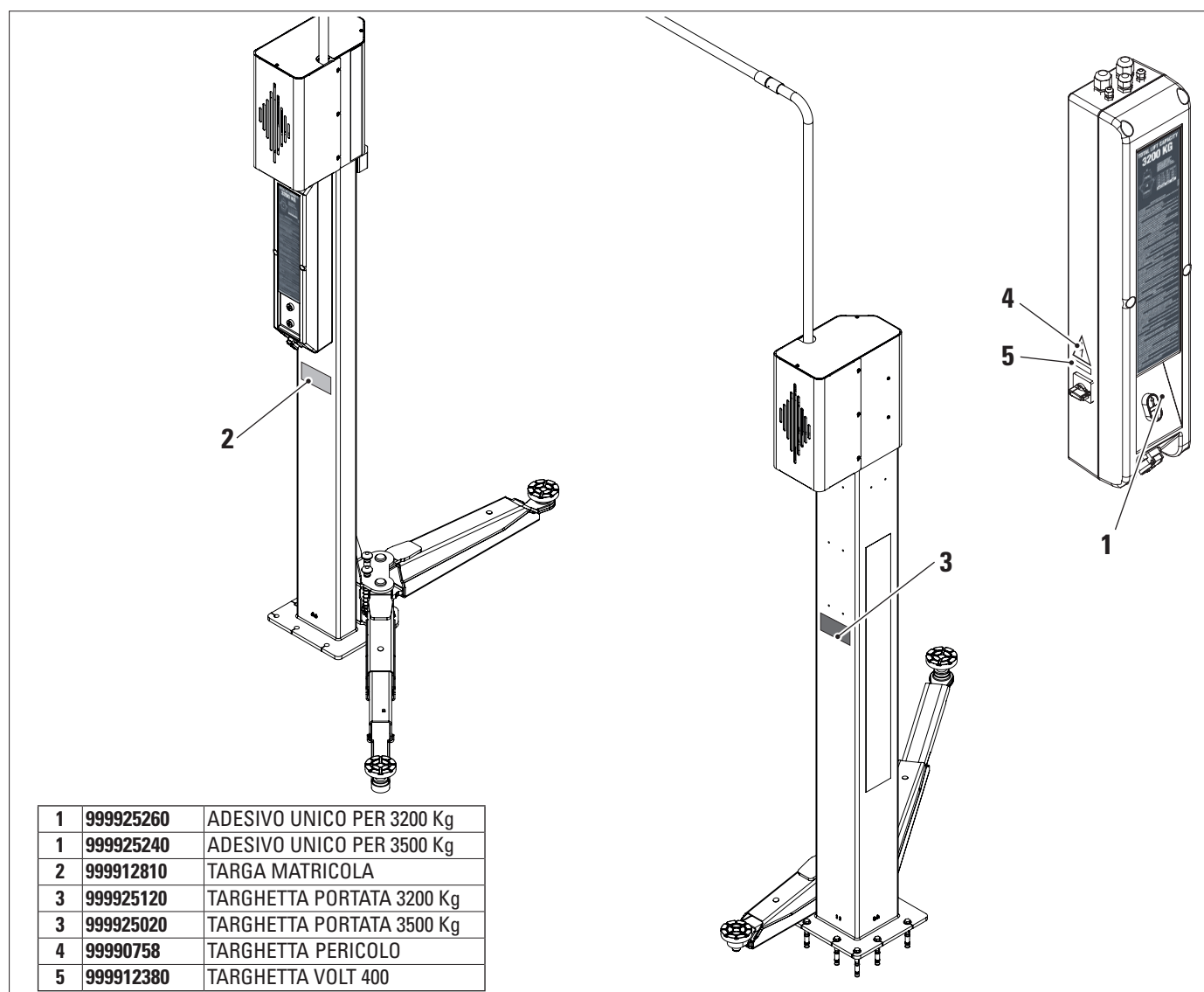

1	999925260	ADESIVO UNICO PER 3200 Kg
1	999925240	ADESIVO UNICO PER 3500 Kg
2	999912810	TARGA MATRICOLA
3	999925120	TARGHETTA PORTATA 3200 Kg
3	999925020	TARGHETTA PORTATA 3500 Kg
4	99990758	TARGHETTA PERICOLO
5	999912380	TARGHETTA VOLT 400

KAP. 5 ANFORDERUNGEN FÜR DIE INSTALLATION



5.1 MINDESTERFORDERNISSEN FÜR DEN AUFSTELLUNGORT

Sicherstellen, dass der vorgesehene Installationsort der Maschine den folgenden Merkmalen entspricht:

- die Nutzung der Hebebühne ist ausschließlich in geschlossenen Räumen zulässig, in denen keine Explosions- oder Brandgefahren bestehen;
- die Hebebühne ist nicht für den Einsatz geeignet, der eine Fahrzeugwäsche vorsieht;
- ausreichende Beleuchtung (jedoch ein Ort, der nicht geblendet wird oder stark beleuchtet ist). Bezug auf die Norm UNI 10380;
- Ort, der keinen Witterungseinflüssen ausgesetzt ist;
- Ort, an dem ein ausreichender Luftaustausch stattfindet;
- schadstofffreie Umgebung;
- Geräuschpegel unter den geltenden gesetzlichen Anforderungen von I 70 dB (A);
- Raumtemperatur: min. 5° - max. 55°;
- der Arbeitsplatz darf keinen gefährlichen Bewegungen durch andere in Betrieb stehende Maschinen ausgesetzt sein;
- der Raum, in dem die Maschine aufgestellt ist, darf nicht für das Lagern von explosiven, ätzenden und/oder giftigen Stoffen verwendet werden;
- der Abstand der Säulen zu Wänden oder festen Einrichtungen muss mindestens 50 cm betragen;
- bei der Wahl des Aufstellungsortes ist zu berücksichtigen, dass der Bediener von der Steuerposition aus die gesamte Maschine und den umliegenden Bereich einsehen können muss. Er muss in diesem Bereich den Aufenthalt unbefugter Personen verhindern; außerdem dürfen sich dort keine Gegenstände befinden, die eine Gefahrenquelle darstellen könnten.

Alle Installationsarbeiten, die den Anschluss an externe Versorgungs vorsehen (insbesondere elektrische), müssen von fachlich qualifiziertem Personal durchgeführt werden.

Die Installation muss vom autorisierten Personal unter Beachtung der besonderen, eventuell in diesem Handbuch gegebenen Anweisungen durchgeführt werden. Bei Zweifeln die Vertragskundendienst oder den technischen Kundendienst von ROTARY kontaktieren.

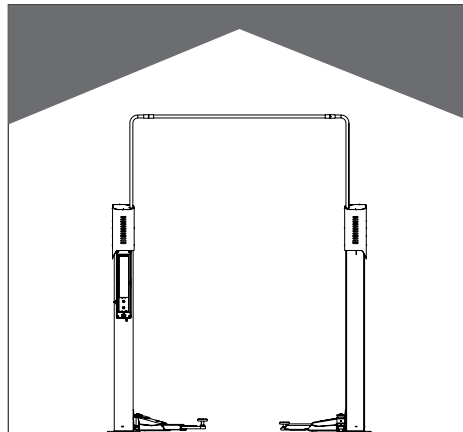

JA

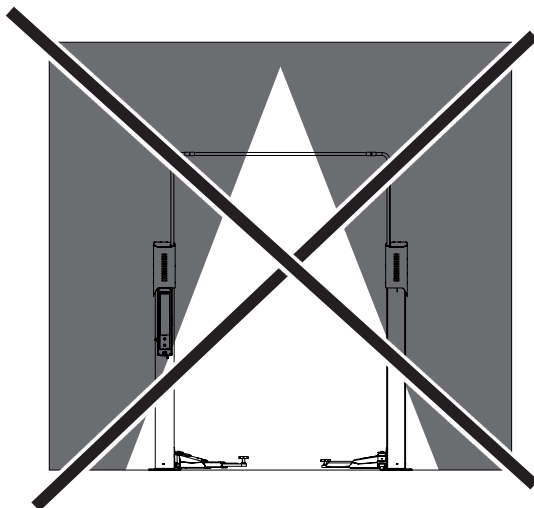

NEIN

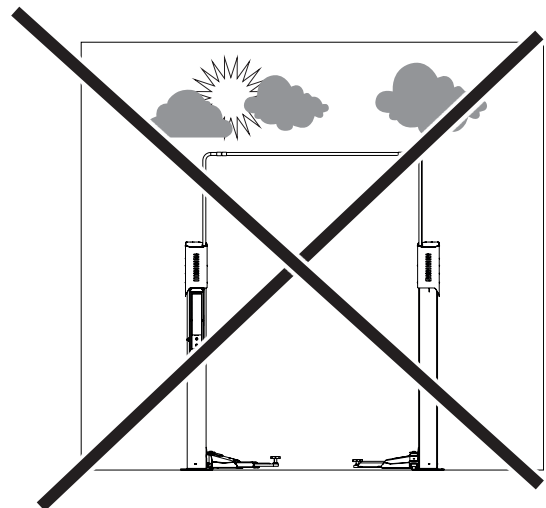

NEIN

5.2 ANFORDERUNGEN AN DEN BODEN



Die Hebebühne muss auf einem ebenen, horizontalen Boden installiert werden, der die in der Tabelle (Abb. B) angegebenen, AUF DEN TRAGEN DEN BODEN ÜBERTRAGEN EN LASTEN tragen kann. Die Mindestanforderungen müssen sein:

- a) Betongüte: mindestens C25/30
- b) Mindeststärke des Bodenbelags: 160 mm (ohne Bodenbeläge und zugehörige Estriche) (*)

Es wird empfohlen, die Eignung für die Installation durch einen qualifizierten Techniker prüfen zu lassen

(*) Die Mindeststärke hängt von der Art des verwendeten Dübels ab

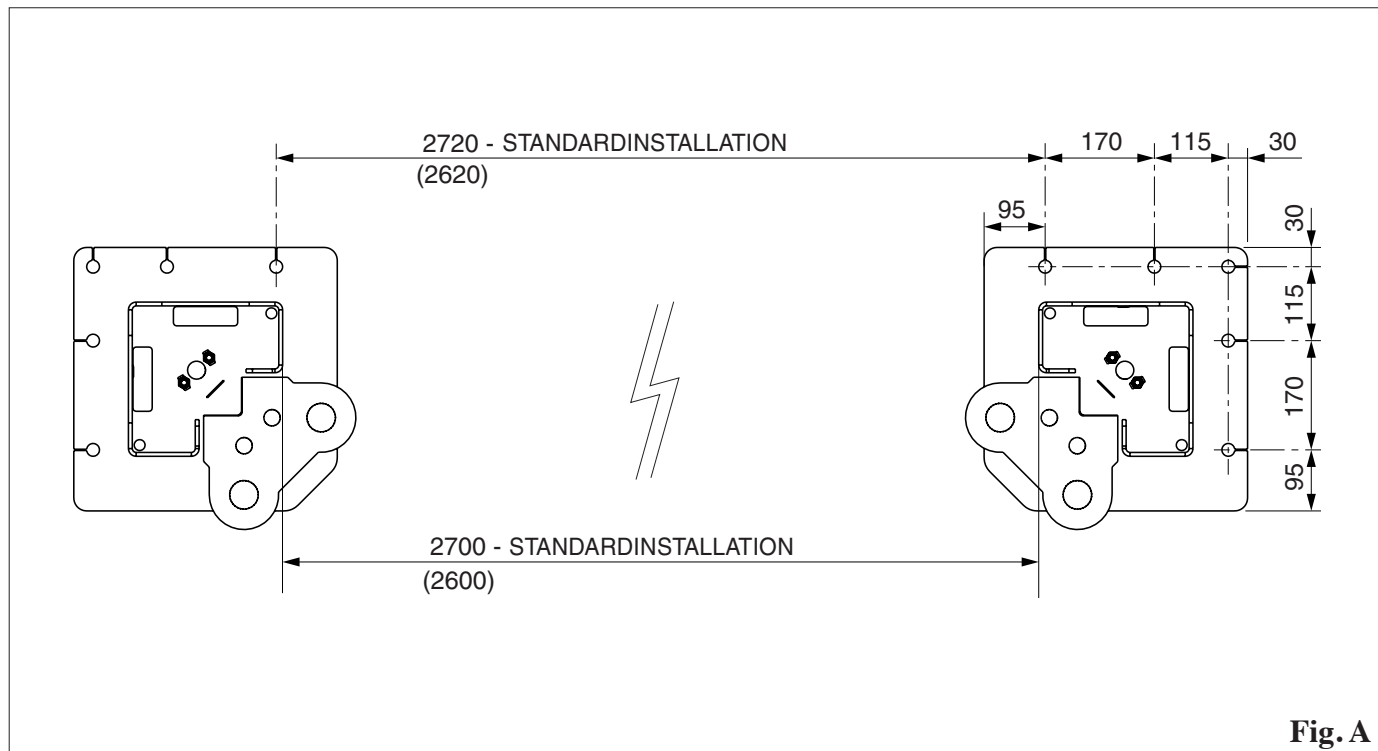

Fig. A



Abb. B

KAP. 6 TRANSPORT UND VORINSTALLATION

- Die Hebebühne wird gemäss Abbildung geliefert (Abb A).
- Die Verpackung (1) enthält Zubehörteile und Kleinteile zur Komplettierung des Zusammenbaus.
- Beim Anheben gemäss Abbildung vorgehen (Abb B).
- Vorsichtig die verschiedenen Elemente zum Ort, wo die Verpackung entfernt wird, transportieren.

- Für die Transportmanöver der Einrichtung zum ausgesuchten Aufstellungsort (oder bei weiteren Transportmanövern) folgende Punkte beachten:

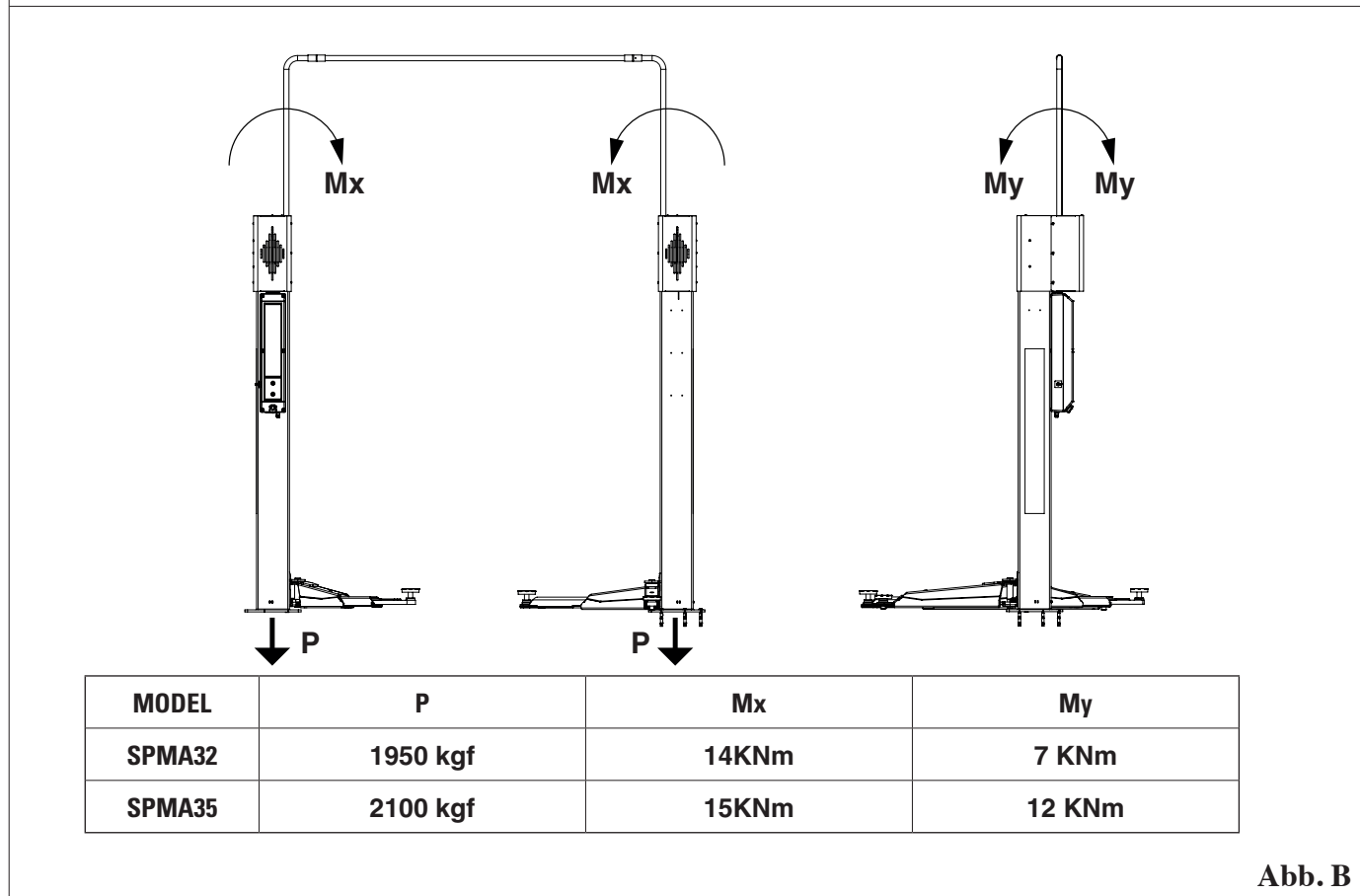
- Vorsichtig anheben, die Last ordnungsgemäss mit geeigneten, sich in einwandfreiem Zustand befindenden Hilfsmitteln stützen. Dabei die auf der Abbildung angegebenen Einhakungspunkte berücksichtigen (Abb B).
- Unerwartete Erhöhungen und Ruckbewegungen meiden. Vorsicht bei Unebenheiten, Querrinnen usw.
- Besondere Vorsicht bei herausstehenden Teilen: Hindernisse, schwierige Durchgänge usw.
- Der auszuführenden Arbeit angemessene Kleidung und individuelle Schutzvorrichtungen tragen.
- Die entfernten Verpackungsteile an einem für Kinder und Tiere unzugänglichen Sammelplatz bis zum Entsorgen aufbewahren.
- Bei Anlieferung die Verpackung auf ihre Vollständigkeit überprüfen. Nach dem Auspacken kontrollieren, ob die Ware evtl. Beschädigungen aufweist.



Abb. A

Vorgehensweise beim Handling:

- Die Ringschraube (2) (*optional*) auf der Schraube (3) montieren.
- Den Gurt (4) wie abgebildet in die Ringschraube und auf den Lastenträger anordnen.
- Die Säule vorsichtig anheben, bis sie vertikal ausgerichtet steht.
- Den Gurt aus der Ringschraube lösen.
- Die Ringschraube (2) entfernen.

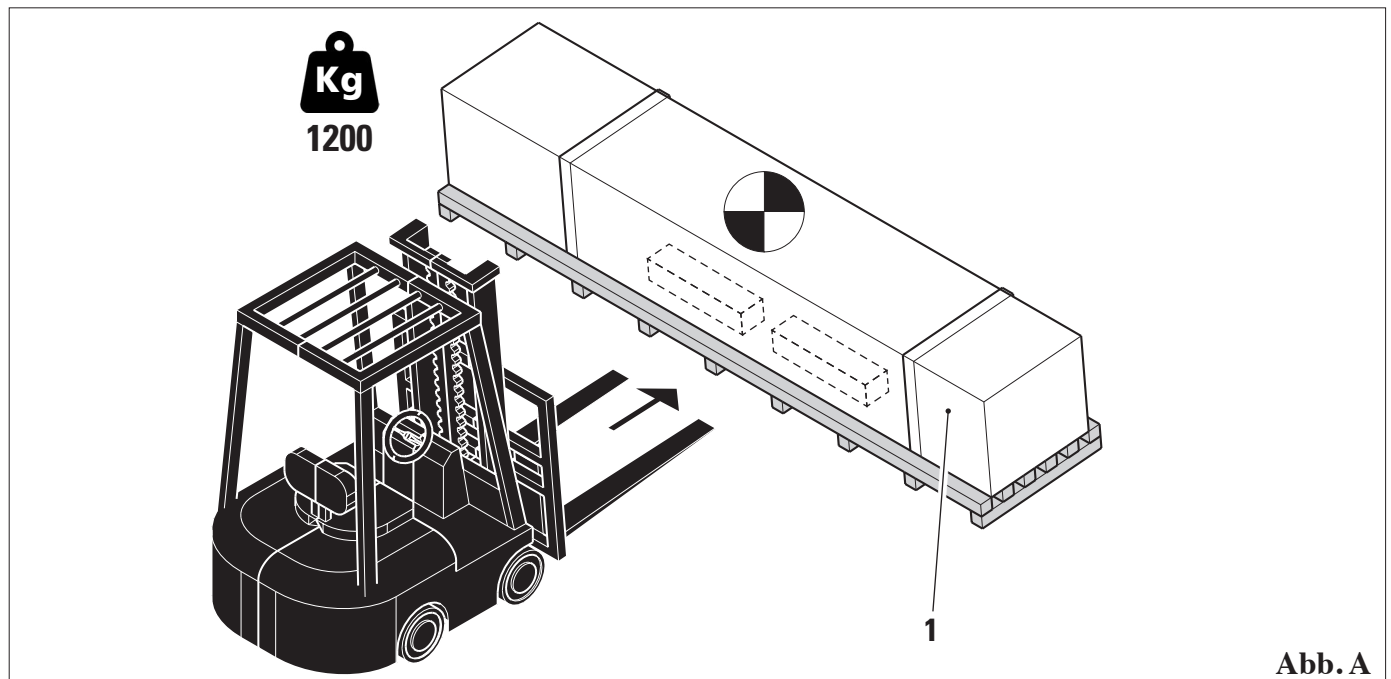

Abb. B

KAP. 7 AUFSTELLUNG

7.1 DÜBEL

Die Hebebühne muss mit mechanischen Spreizdübeln des Typs HILTI HSL-3 M12 oder ähnlichen oder mit chemischen Dübeln des Typs HILTI HVU-M12 oder ähnlichen (mit Gewindestange M12 in Stahlklasse 5.8 oder höher) am Boden befestigt werden. Im Verhältnis zur Tiefe des Betons zum Bodenniveau MÜSSEN DIE DÜBEL EINE LÄNGE HABEN, DIE AUSREICHT, UM DEN TRAGENDEN BODEN ZU ERREICHEN. (siehe Abb. A-B).

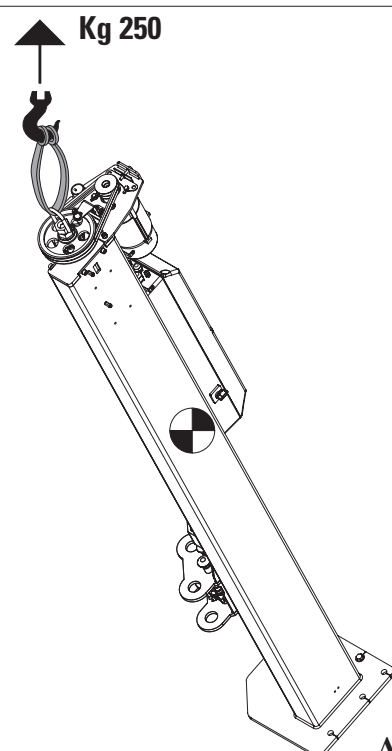
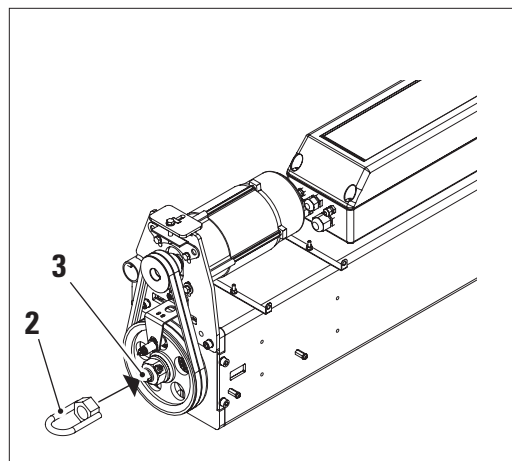
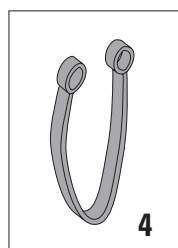
7.2 BETON

Bei Beton mit geringerer Güteklasse empfiehlt sich die Verwendung geeigneter chemischer Dübel.

Hinweis: Es wird empfohlen, den Sockel der Säulen direkt auf den Beton zu stellen, auch wenn dieser mit einem Bodenbelag belegt ist. Ist dieser jedoch von guter Qualität, können die Säulen mit Dübeln von geeigneter Länge direkt am Boden befestigt werden.

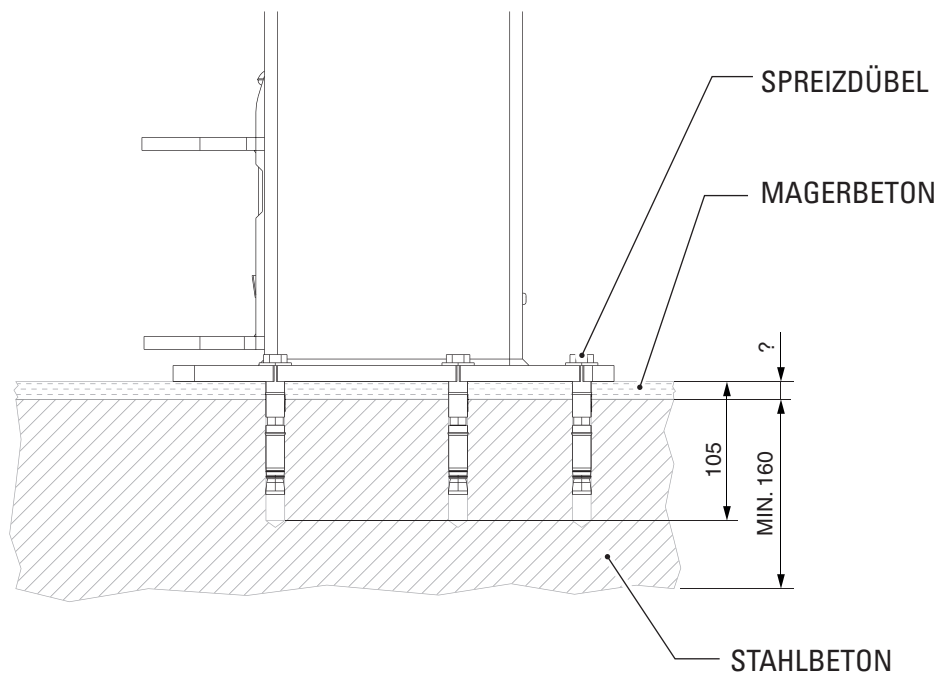
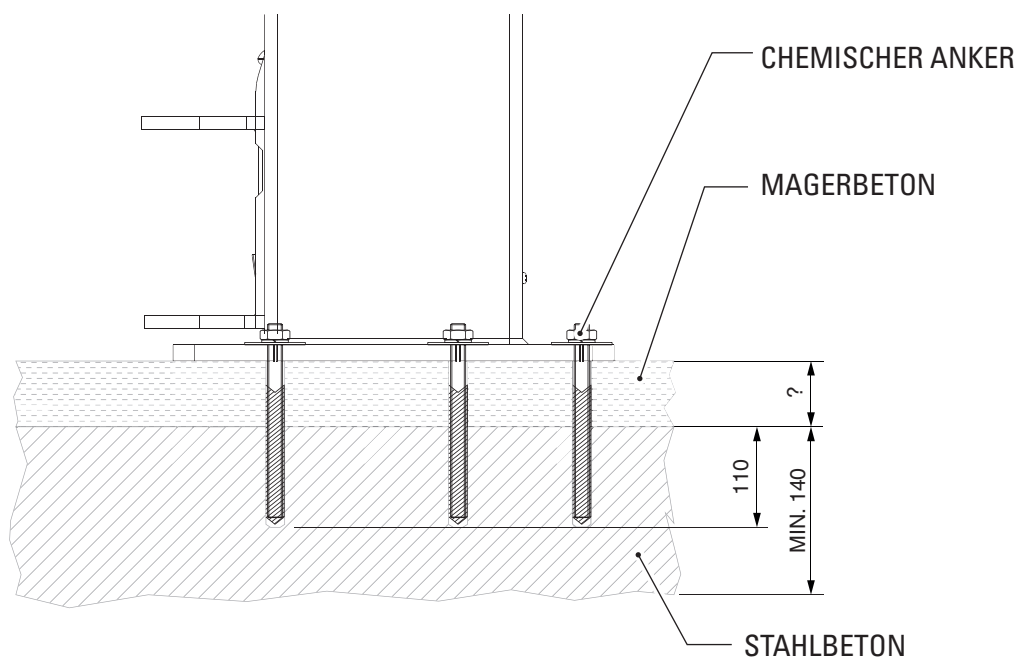
Abb. A

Abb. B

7.3 INSTALLATIONSANWEISUNGEN

Die Säulengrundplatten dienen als Schablonen für die Bohrungen



Hinweis: Die technischen Spezifikationen des Dübelherstellers für die Montage- und Anbringungsmethoden der Dübel beachten. Installationsvorgang:

- eine Säule vertikal positionieren;
- Eventuell unter der Basisplatte vorhandene Luftspalte ausdistanzieren (Abb. B)
- die Bohrungen anzeichnen und entsprechen dem vom Dübelhersteller angegebenen Verfahren die Bohrungen setzen;
- den Dübel in der Position befestigen;
- die andere Säule vertikal aufrichten und im in **Kap. 5.2** angegebenen Abstand positionieren;
- die oben beschriebenen Bohr- und Dübeleinsatzschritte an beiden Säulen ausführen.

! **!** Nach ca. 10 Läufen unter voller Belastung das Spannmoment der Dübel überprüfen.
Diese Kontrolle ist alle 3 Monate zu wiederholen.

- Das Kabelführungsrohr (1) auf den Motorträgerplatten montieren.
- Das Stromkabel (2) durch das Rohr (1) ziehen.
- Die Anschlüsse am Abzweigkasten (Abb. C) herstellen.



Abb. A



Abb. B

Abb. C

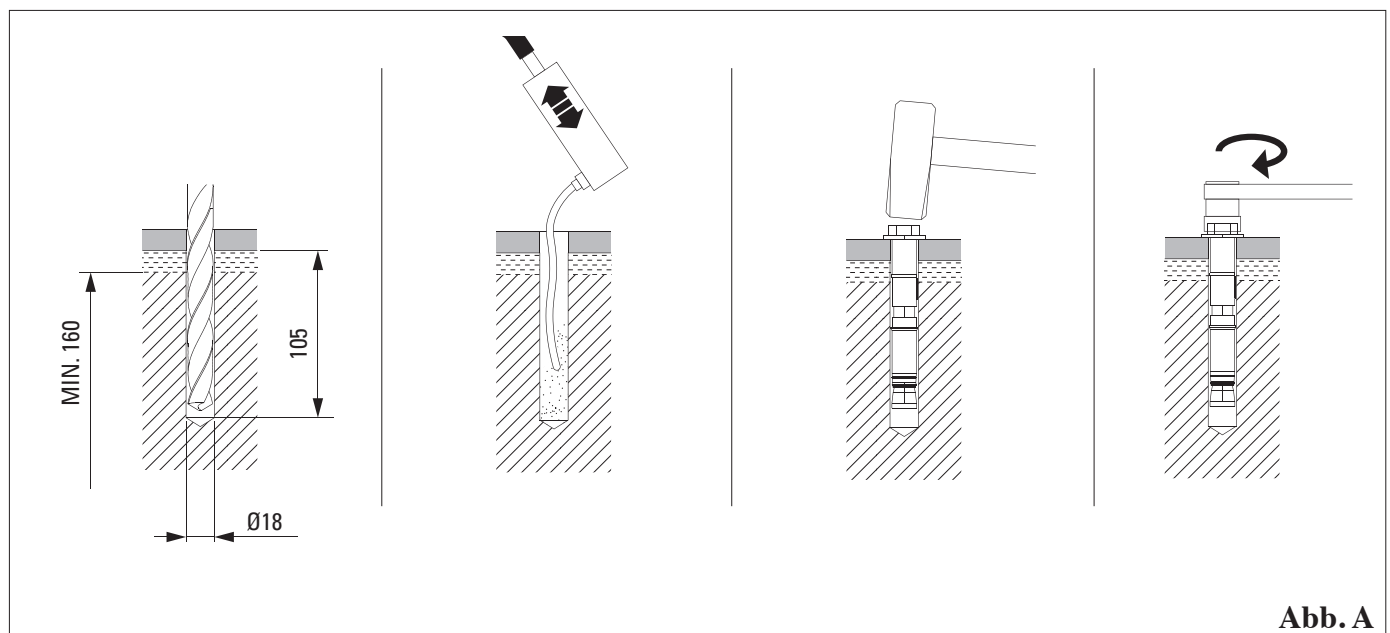
7.4 KONTROLLE DER SPANNUNG

Sicherstellen, dass die für die Anlage ausgelegte Spannung der Netzspannung entspricht. Andernfalls muss die elektrische Anlage ausgewechselt werden und ein Spannungswechsel am Motor erfolgen.

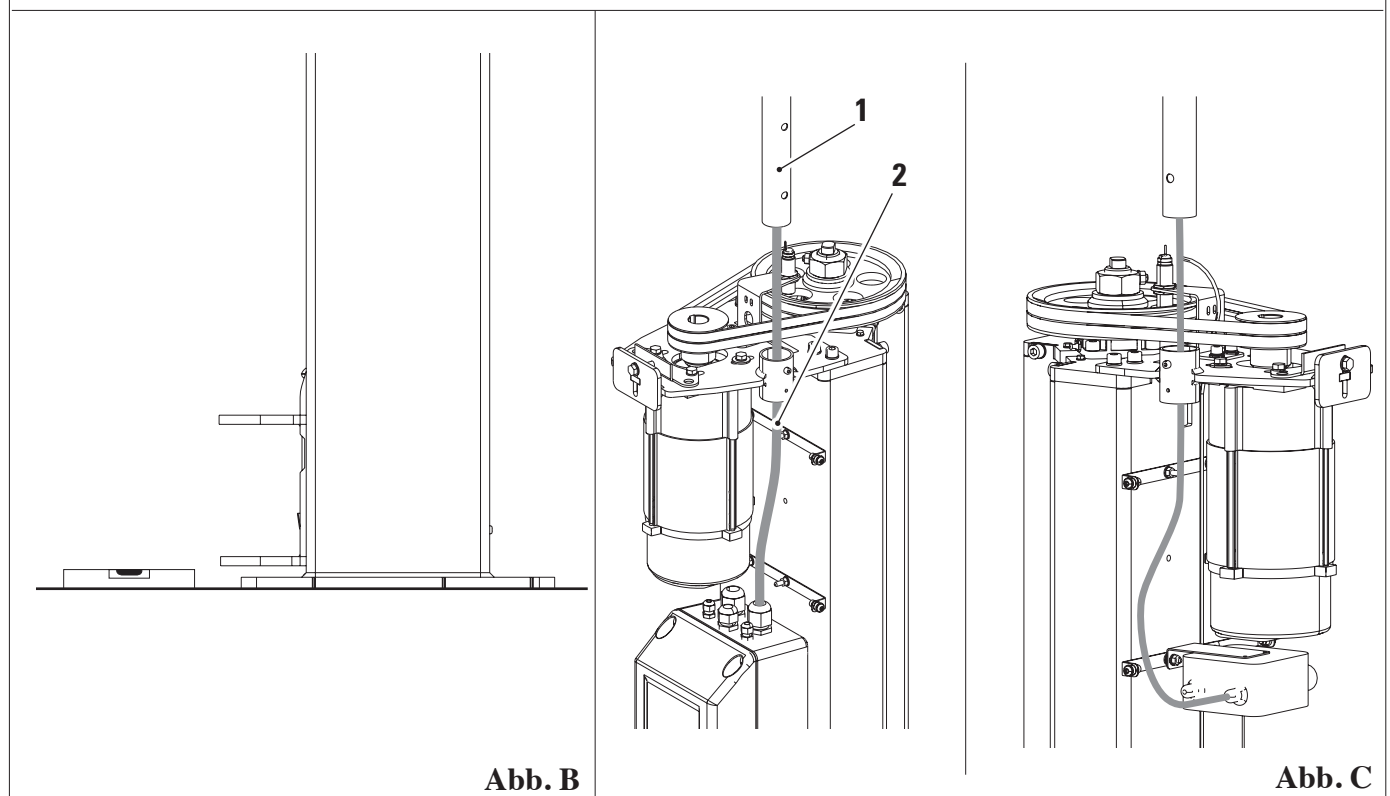

7.5 NETZANSCHLUSS

Dreiphasen-Version: 400V 50Hz 380V 60Hz
 Kabelquerschnitt >= 4mmq 3poli + terra P=11KW I=20A
 Dreiphasen-Version: 230V 50Hz 220V 60Hz
 Kabelquerschnitt >= 6mmq 3poli + terra P=11KW I=32A

Ebenfalls kontrollieren, dass eine automatische Überstrom-Abschaltvorrichtung mit einem 30 mA Schutzschalter vorgeschaltet ist.

7.6 ANSCHLÜSSE

- Das Zuführungskabel im Schaltschrank durch die Kabelklemme führen und die Drähte an die Klemmleiste anschliessen (siehe Schaltplan).

Vor der Installation.

Vorsicht: aus Verpackungsgründe können die Schlitten der Hebebühne nicht ausgerichtet sein. Die Schlitten bis zum Boden (Senkansschlag) absenken, dabei die Angaben im Kap.“8.5” im Handbuch befolgen.



Alle Eingriffe (auch wenn geringfügig) auf elektrischen Teilen sind durch Fachpersonal auszuführen).

MOTORANSCHLUSS

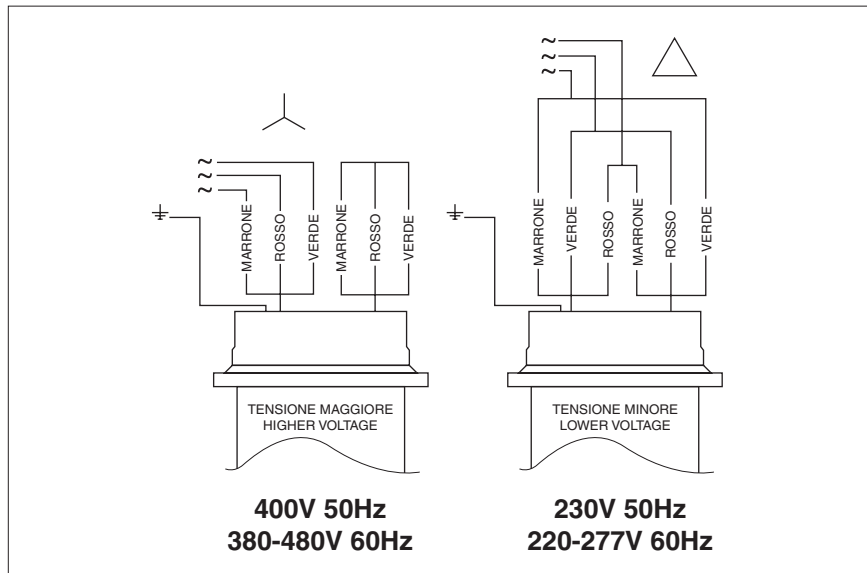

ANSCHLUSS DES TRANSFORMATORS

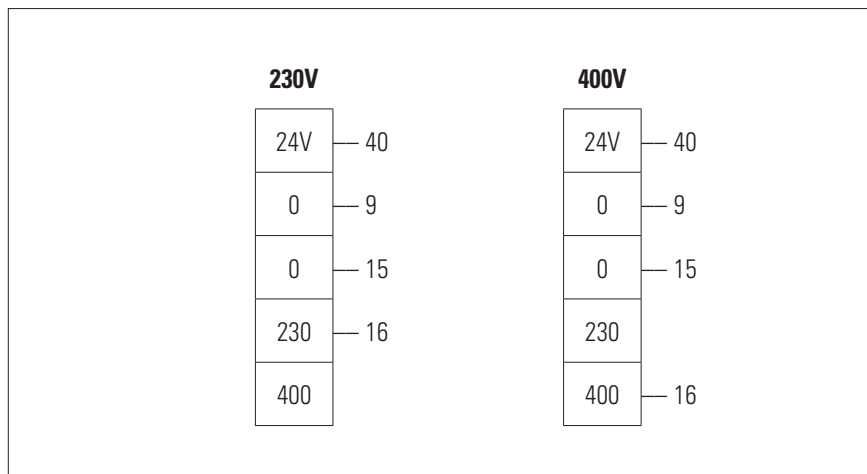

SICHERUNGEN

230V	400V
32A	20A

Die Elektroanlage ist auf die Spannung ausgelegt, die auf dem Seriennummernschild angegeben ist.

7.7 KOMPLETTIERUNG UND KONTROLLE

- Herunterfahren und von Hand den unteren Endschalter betätigen. Die Abwärtsbewegung muss sich unterbrechen.
- Hochfahren, bis die Hubwagen ihren kompletten Hublauf ausgeführt haben und sicherstellen, dass der Stopp durch den Einsatz des oberen Endschalters erfolgt.
- Die Säulentöpfe bis zum angegebenen Ölstand mit Öl ESSO GEAR OIL GX 85W - 140 füllen (siehe Kap. 10).
- Die Sensorplatte der Riemenscheibe an beiden Säulen montieren, Abb. A. Kontrollieren, dass zwischen dem Sensor und der Platte ein Abstand von 0,5 mm gegeben ist (Abb. B).

- Die Abdeckungen montieren, siehe Abb. C:
- Die Abdeckung (1) montieren und sie dabei an den Halterungen (2) befestigen.
- Die Abdeckung (3) montieren und sie dabei an der Abdeckung (1) und den Halterungen (4) befestigen.
- Die Abdeckung (5), indem Sie sie an den Abdeckungen (1) und (3) befestigen.

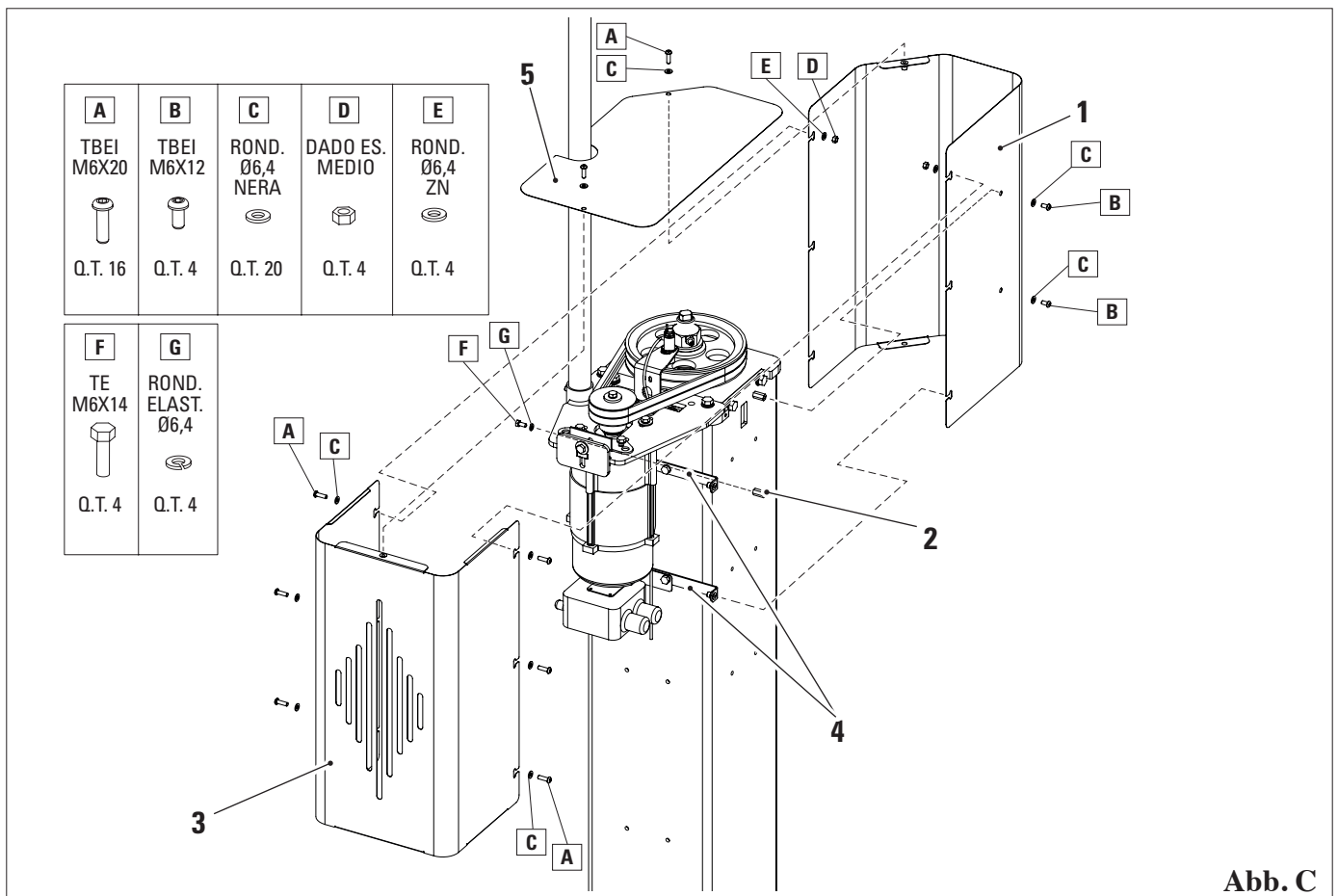
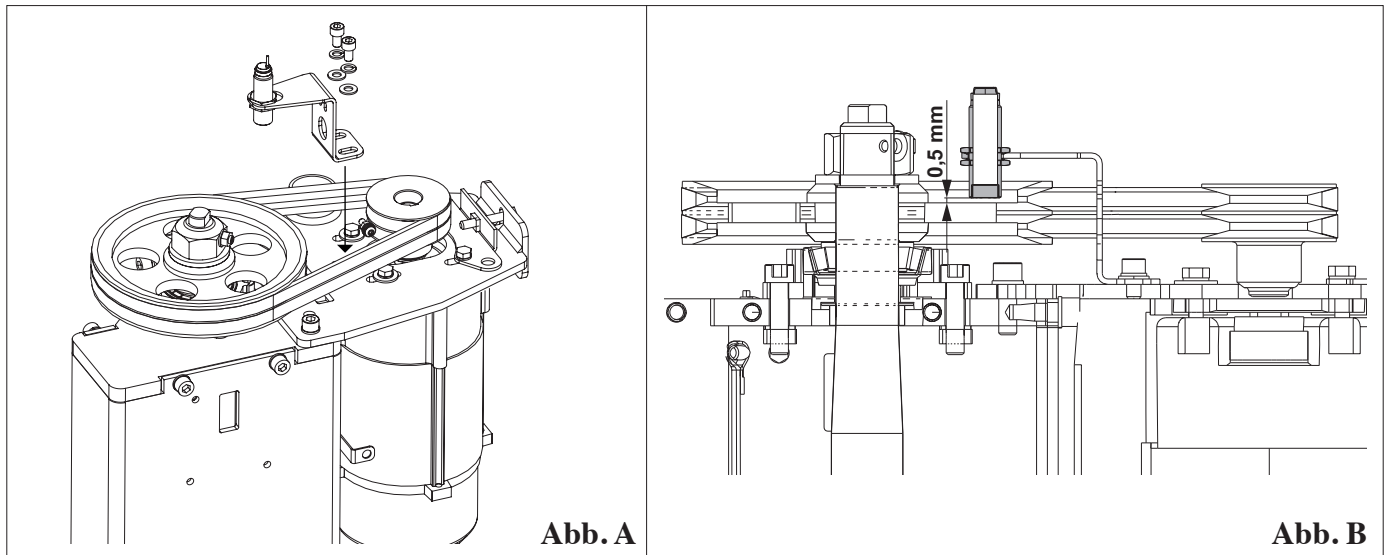

Das Typenschild muss nach der Installation gut sichtbar bleiben.

Abb. C

7.8 MONTAGE DER MONTAGEARME



- Die Hubwagen auf eine Höhe von 70-80 cm fahren.
- Die langen und kurzen Arme montieren:

das Zahnrad (1) entfernen, indem Sie die entsprechenden Schrauben herausdrehen; den Stift (2) entfernen; den Arm in die Schlittenflügel einsetzen und den Stift (2) und das Zahnrad (1) wieder anbringen, indem Sie es mit den Schrauben sichern.

7.9 VERWENDUNG VON ZUBEHÖR

Die Hebebühne kann mit Zubehörteilen verwendet werden, um die Arbeit des Bedieners zu erleichtern.

  *Es darf nur Originalzubehör des Herstellers verwendet werden.*

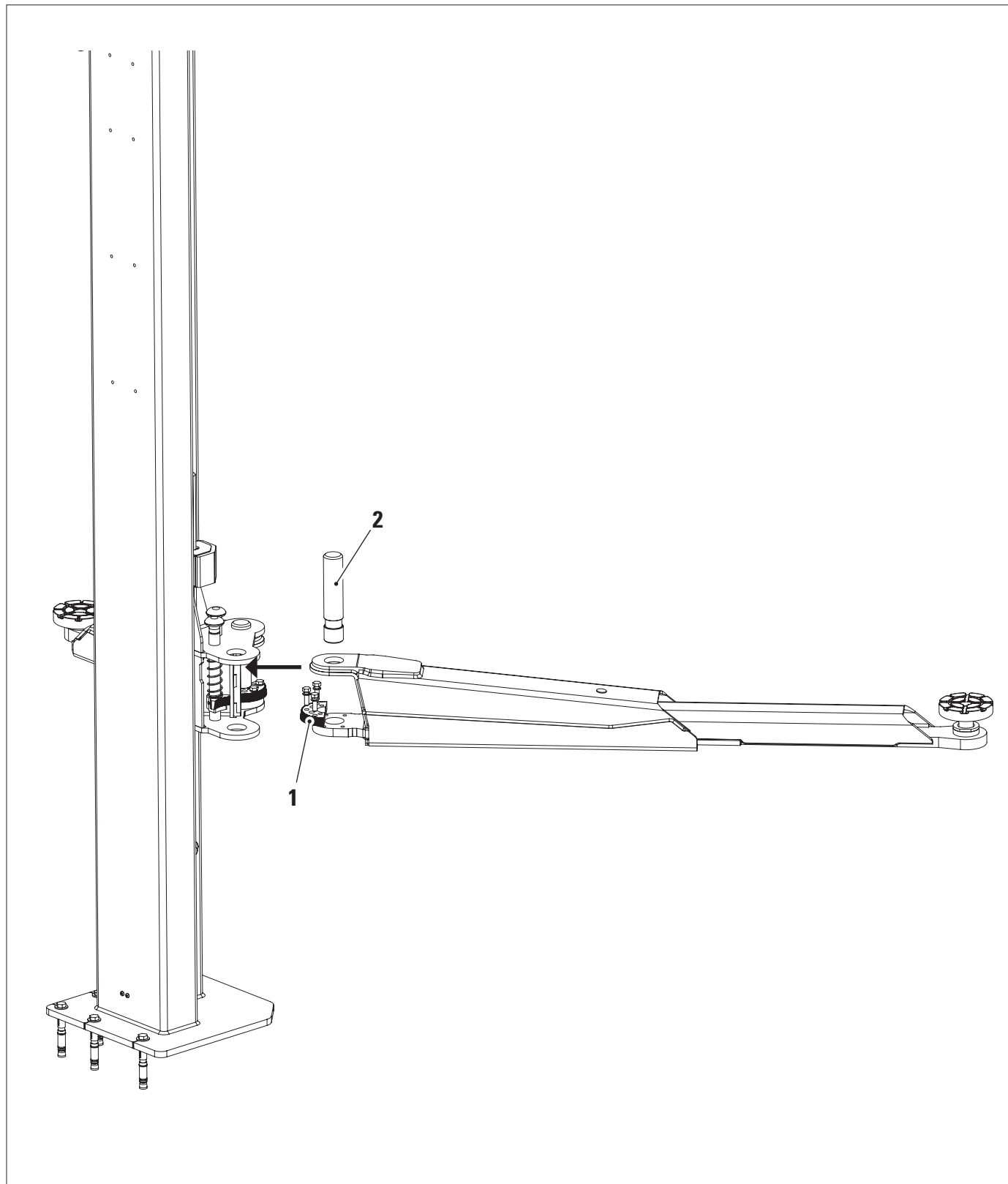

KAP. 8 DIE BEDIENUNG DER HEBEBÜHNE



8.1 VORSICHTSMASSNAHMEN



Es ist absolut verboten, sich während der Hebe- und Senkvorgänge unter dem Fahrzeug aufzuhalten!

- Sicherstellen, dass während der Arbeitsvorgänge keine Gefährdungen hervorgerufen werden. Sobald irgendwelche Betriebsstörungen auftreten, die Hebebühne sofort anhalten und den Kundendienst des autorisierten Händlers zu Rate ziehen.
- Sicherstellen, dass der Arbeitsbereich um die Hebebühne frei von potentiell gefährlichen Gegenständen ist und dass der Fussboden nicht mit Ölresten (oder anderen schmierigen Substanzen) beschmutzt ist, die eine potentielle Gefährdung für den Bediener darstellen könnten.
- Der Bediener muss angemessene Arbeitskleidung tragen: Schutzbrille, Handschuhe und Maske zum Schutz vor aufgewirbelten Staub- und Schmutzpartikeln. Das Tragen herabhängender Gegenstände wie Kettchen, Armbänder u.ä. ist zu vermeiden. Lange Haare sind durch geeignete Massnahmen zu schützen. Die Schuhe müssen der auszuführenden Arbeit angemessen sein.
- Sicherstellen, dass durch das Demontieren von Fahrzeugteilen die vorgesehenen und zugelassenen Lastverteilungslimiten nicht überschritten werden.
- Bei Arbeitsvorgängen auf dem aufgehobenen Fahrzeug den Hauptschalter auf Null stellen.

8.2 HANDHABUNG UND VERHALTEN BEIM HEBEBÜHNEBETRIEB

Die nachstehend beschriebenen Vorgehensweisen befolgen:

- Das Gewicht des Fahrzeugs ermitteln.
- Die Lastverteilung bestimmen.
- Sicherstellen, das Fahrzeug so genau wie möglich auf der Hebebühne zentriert wird.
- Die Greifstellen am Fahrzeug ermitteln und die Anweisungen des Herstellers befolgen.
- **Vorgehensweise zur korrekten Positionierung der Stempel:** Die Hände als benutzen, um den Teleskoparm auszufahren (siehe Abbildung); den Stempel ausrichten und ihn an den zuvor ermittelten Greifstellen des Fahrzeugs positionieren. Nicht die Füße und keine anderen Systeme als die aufgeführten verwenden.
- Den Schlitten auf eine Höhe von etwas mehr als 30 cm bringen und durch Drücken auf das Fahrzeug die korrekte Stabilität der Greifpunkte und das Einrasten der Anschläge überprüfen.
- Während der Hebe- und Senkbewegung den Auflagepunkt am Fahrzeug kontrollieren.

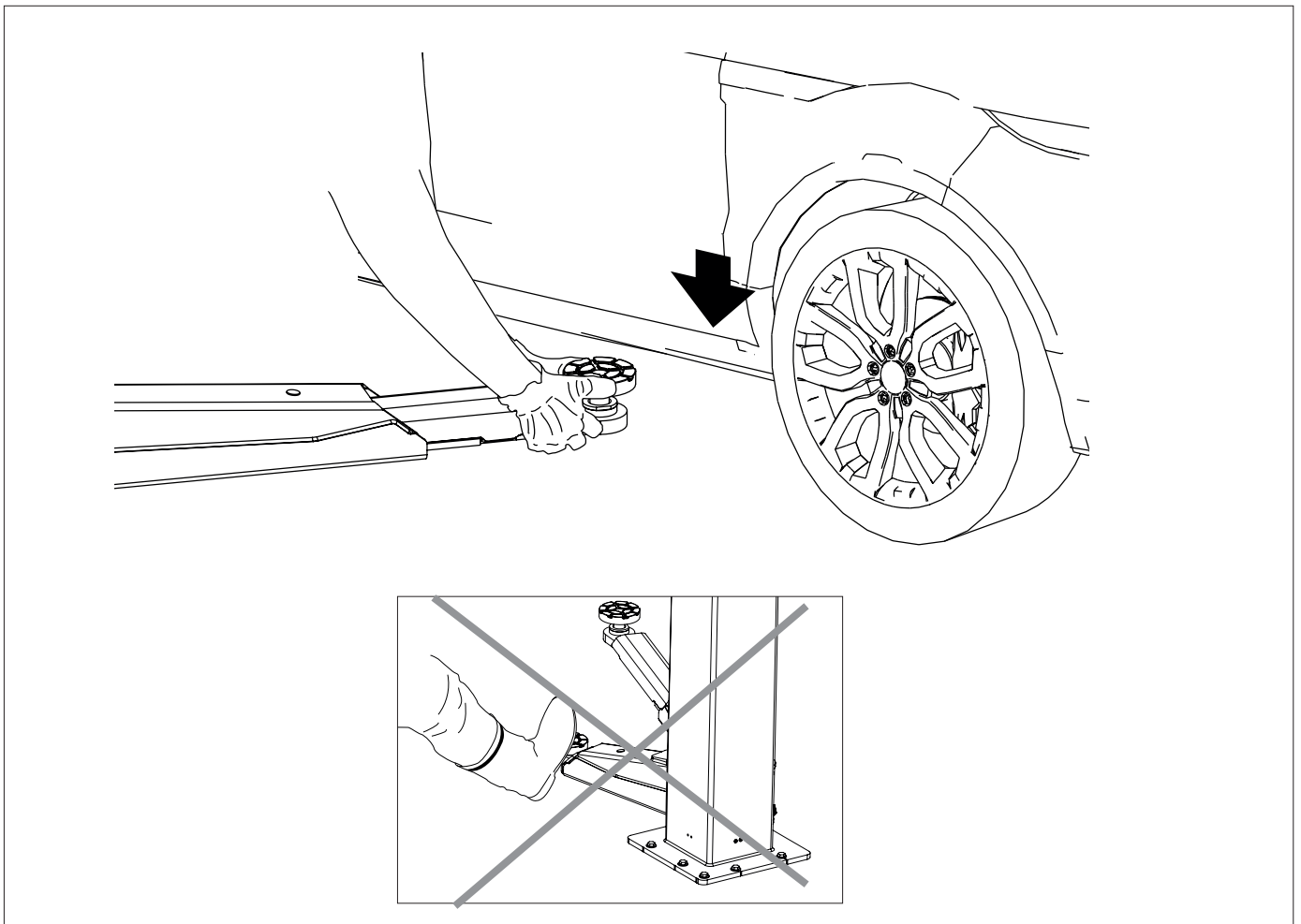

8.3 DIE STEUERUNGEN UND IHRE FUNKTIONEN

 Steuerkästen Art.-Nr. **047303060 - 047303070 / 047303080**

 Identifizierung der Bedien-/Steuerelemente: **SCHALTER (1), TASTE (2), TASTE (3); SUMMER (4), NOT-AUS-TASTE (5)**

Funktion:

	<ul style="list-style-type: none"> • Stromkreis deaktiviert • Mit Vorhängeschloss verriegelte Position 		Gedrückt: Aufwärtsbewegung
	<ul style="list-style-type: none"> • Aktivierter Stromkreis • TEqLINK aktiviert 		Gedrückt: Abwärtsbewegung
	<ul style="list-style-type: none"> • Tasten (2) und (3) deaktiviert • TEqLINK aktiviert • Mit Vorhängeschloss verriegelte Position 		Gedrückt: deaktiviert den Stromkreis
			Aktiv: Hebebühne gesperrt und Schlitten in gefährlicher Höhe bei betätigter Abwärtssteuerung

047303060

Steuerkasten mit Schalter und Auf/Ab-Tasten.

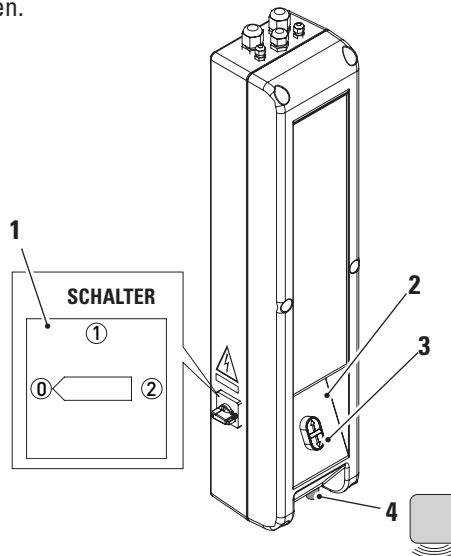
047303070 / 047303080

Doppelter Steuerkasten mit Schalter und Auf-/Ab-Tasten, Not-Aus-Taste.

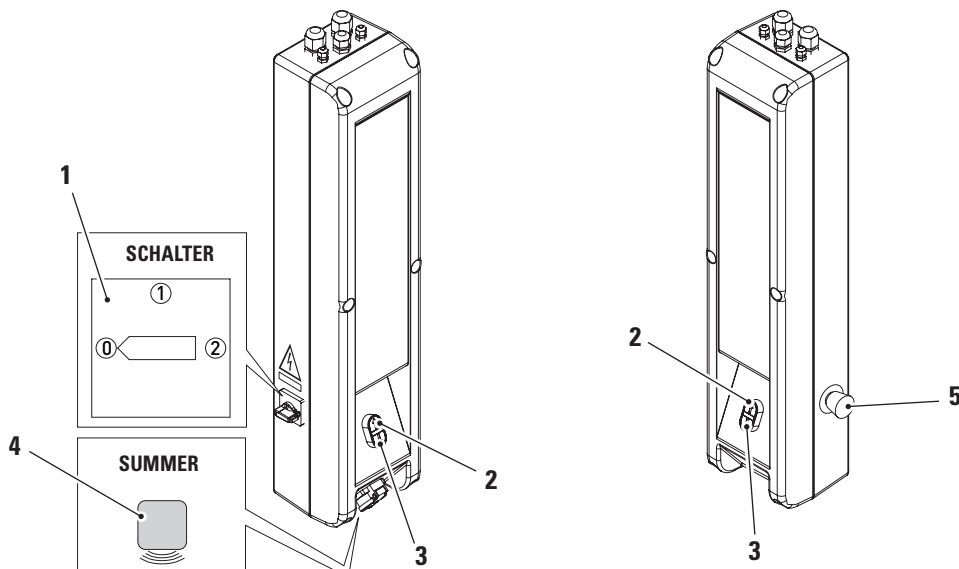

NOT-AUS-PROZEDUR ABSENKEN BEI STROMAUSFALL

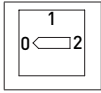

Den Schalter in die Position 0 bringen (um die Möglichkeit einer erneuten Zuschaltung der Stromversorgung auszuschließen).

- SENKEN IM NOT-AUS: Im Falle eines Stromausfalls kann die Last wieder auf den Boden gebracht werden, indem die Abdeckungen oben an den Säulen entfernt und die Stellschrauben mit einem 17 mm-Schlüssel abwechselnd an der Steuersäule und der gegenüberliegenden Säule so gedreht werden, dass der Unterschied zwischen den Schlittenhöhen nicht mehr als 50 mm beträgt. Nach dem erneuten Freischalten des Stromkreises müssen die Schütze zurückgesetzt werden, indem die Hebebühne 5 cm nach oben und dann nach unten gefahren wird.

ACHTUNG! Dieser Vorgang ist von Fachpersonal durchzuführen. Dabei muss die Anordnung der Last beachtet werden, um Ungleichgewichte zwischen den zwei Schlitten zu vermeiden, die die Stabilität der Last beeinträchtigen können.



8.4 UNSACHGEMÄSSE BEDIENUNG DER HEBEBÜHNE

Die Hebebühne ist für das Heben von Fahrzeugen mit den im Kap. 2. und Kap. 3. genannten Eigenschaften bestimmt. Jede andere Betriebsweise ist als unsachgemäss und daher fahrlässig anzusehen. Insbesondere wird strikte verboten:

1. Personen und Tiere anzuheben.
2. Fahrzeuge mit Personen anzuheben.
3. Fahrzeuge mit potentiell gefährlichen, explosiven, korrosiven oder brennbaren Materialien usw. anzuheben.
4. Das Anheben von nicht auf den Aufnahmepunkten positionierten Fahrzeugen.
5. Das Anheben von Fahrzeugen mit Zubehör, die von der RAVAGLIOLI nicht vorgesehen sind.
6. Die Bedienung der Hebebühne seitens nicht entsprechend geschultem und autorisiertem Personal.
- 7) das Verwenden als Wagenheber;
- 8) das Verwenden eines einzigen Armpaars in Längs- oder Querrichtung;
- 9) das Verwenden eines einzigen Arms;
- 10) das Verwenden der Arme für das Zusammendrücken und Quetschen von Material.

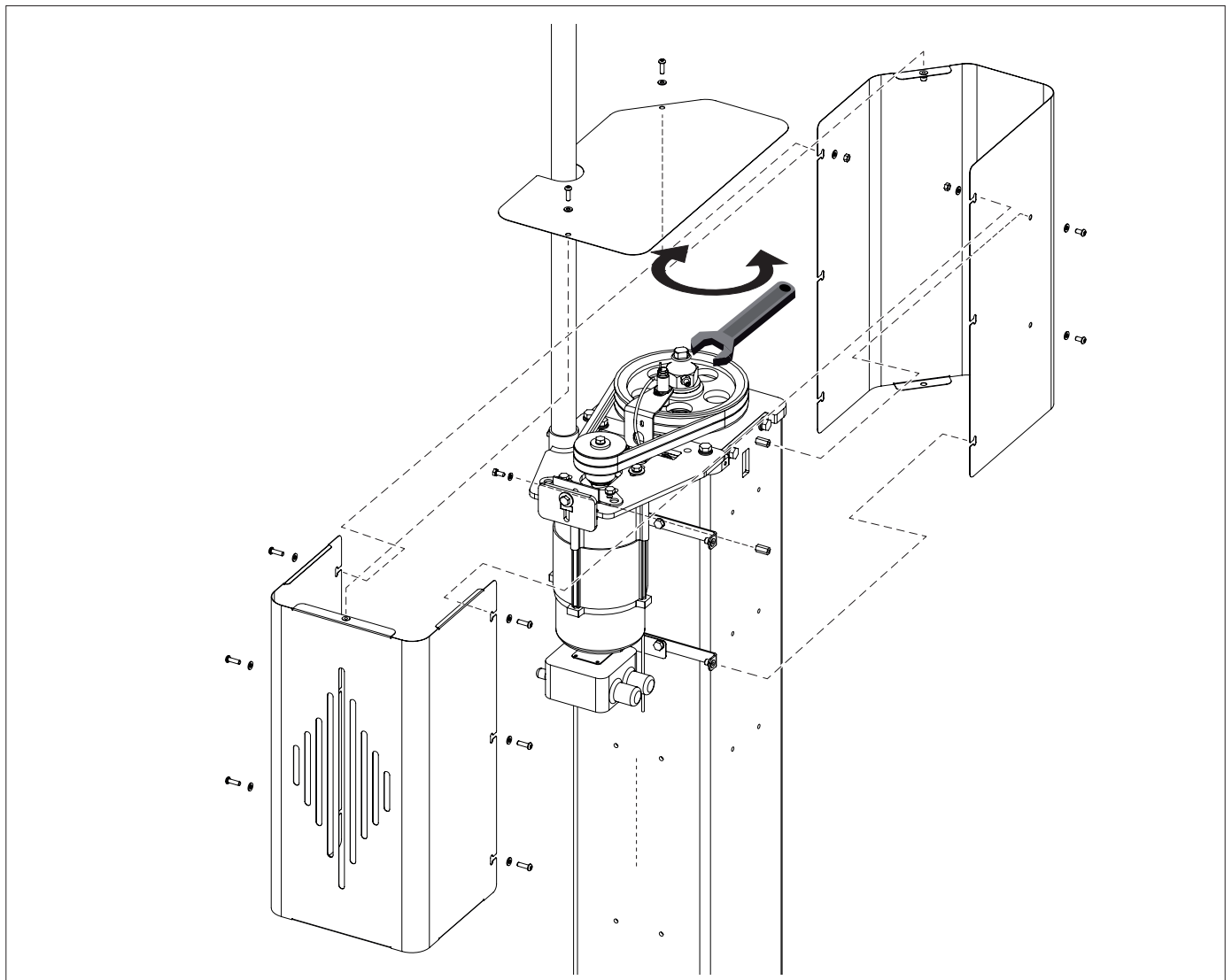

8.5 FUNKTIONSWEISE DER VORRICHTUNG DER SYNCHRONISATIONSKONTROLLE.

Achtung!

Für die Überprüfungen und Notfall-Verfahren ist der Eingriff eines Fachtechnikers erforderlich, da bei anliegender Spannung gearbeitet werden muss.

In der Schalttafel befindet sich die elektronische Platine (1) mit einer LED (2), die aufleuchtet, wenn sich der Schalter unter folgenden Bedingungen befindet:

 Schalter Steuerkasten Art.-Nr. **047303060 - 047303070**

	<ul style="list-style-type: none"> • Aktivierter Stromkreis • TEqLINK aktiviert
	<ul style="list-style-type: none"> • Tasten (4) und (5) deaktiviert • TEqLINK aktiviert • Mit Vorhängeschloss verriegelte Position

Problem: Hebebühne gesperrt (Meldung mittels Tonzeichen).

Abhilfe: Senkung im Not-Aus möglich (Senken eines einzelnen Schlittens).

- Befindet sich die Hebebühne im Sperrzustand, können die Schlitten heruntergefahren werden.

- Auf drehen.

 - Den Deckel des Schaltkastens entfernen.
 - Den Hebel (3) nach unten (auf manuellen Betrieb **A**) verstellen.

- Auf drehen.

Senken einzelner Schlitten. Die Senksteuerung  betätigen und gleichzeitig die folgenden Tasten drücken:

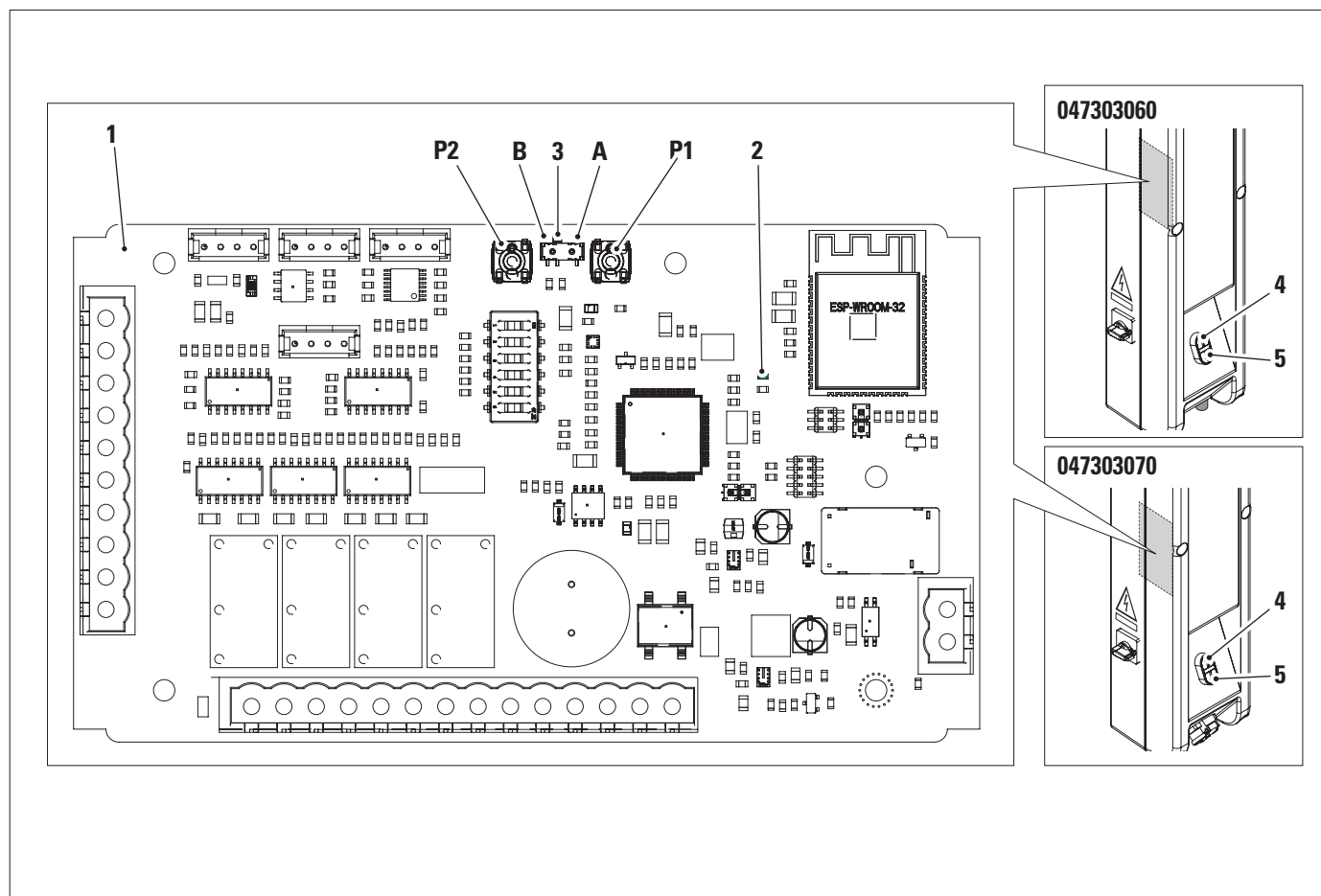
 - die Taste **P1** drücken, um den Schlitten der Steuersäule zu bewegen; die Taste **P2** drücken, um den Schlitten der gegenüberliegenden Säule zu bewegen.



Achtung: Während des Anstiegs im manuellen Betrieb ist das Synchronisationssystem der Schlitten nicht aktiv. Die Manöver müssen korrekt und mit höchster Vorsicht durchgeführt werden, um zu vermeiden, dass das Fahrzeug die Ausrichtung verliert, was gefährlich werden kann.

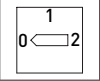

- Beide Schlitten nach unten fahren, der Letzte der am Anschlag angelangt, setzt die Sperre zurück (Tonzeichen erloschen bei betätigter Senksteuerung).

- Auf  drehen.

- Auf der Platine, den Hebel **(3)** auf **(B)** stellen (auf automatischen Betrieb).
 - Den Deckel des Schaltkastens montieren.

Hinweis: Im manuellen Betrieb ist nur das Senken zulässig.

Sollte das Manöver nicht umsetzbar sein, bedeutet dies, dass die Platine in den Sicherheitssperrzustand geschaltet hat, da eine gefährliche Bedingung erfasst wurde.

Zum Rücksetzen der Sicherheitssperre wie folgt verfahren:

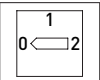
- Auf  drehen.

- Auf der Platine, den Hebel **(3)** auf **(A)** stellen (auf manuellen Betrieb).

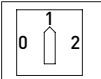
- Die Tasten **P1** und **P2** gleichzeitig drücken und  drehen.

- Die Tasten **P1** und **P2** für 5 Sekunden gedrückt halten.
 - Die LED **(1)**, die bereits leuchtet, blinkt ein Mal auf.
 - Den Hebel **(3)** auf **(B)** (auf den automatischen Betrieb) stellen.

Achtung:

- Wurde die Sperre von einer Störung der Hardware (Platine oder elektrische Anlage) ausgelöst, wird die Sperre sofort erneut ansprechen.
- Ist die Störung in der Platine aufgetreten, muss diese ersetzt werden.
- Ist die Störung in der Anlage aufgetreten, muss der Defekt behoben werden.

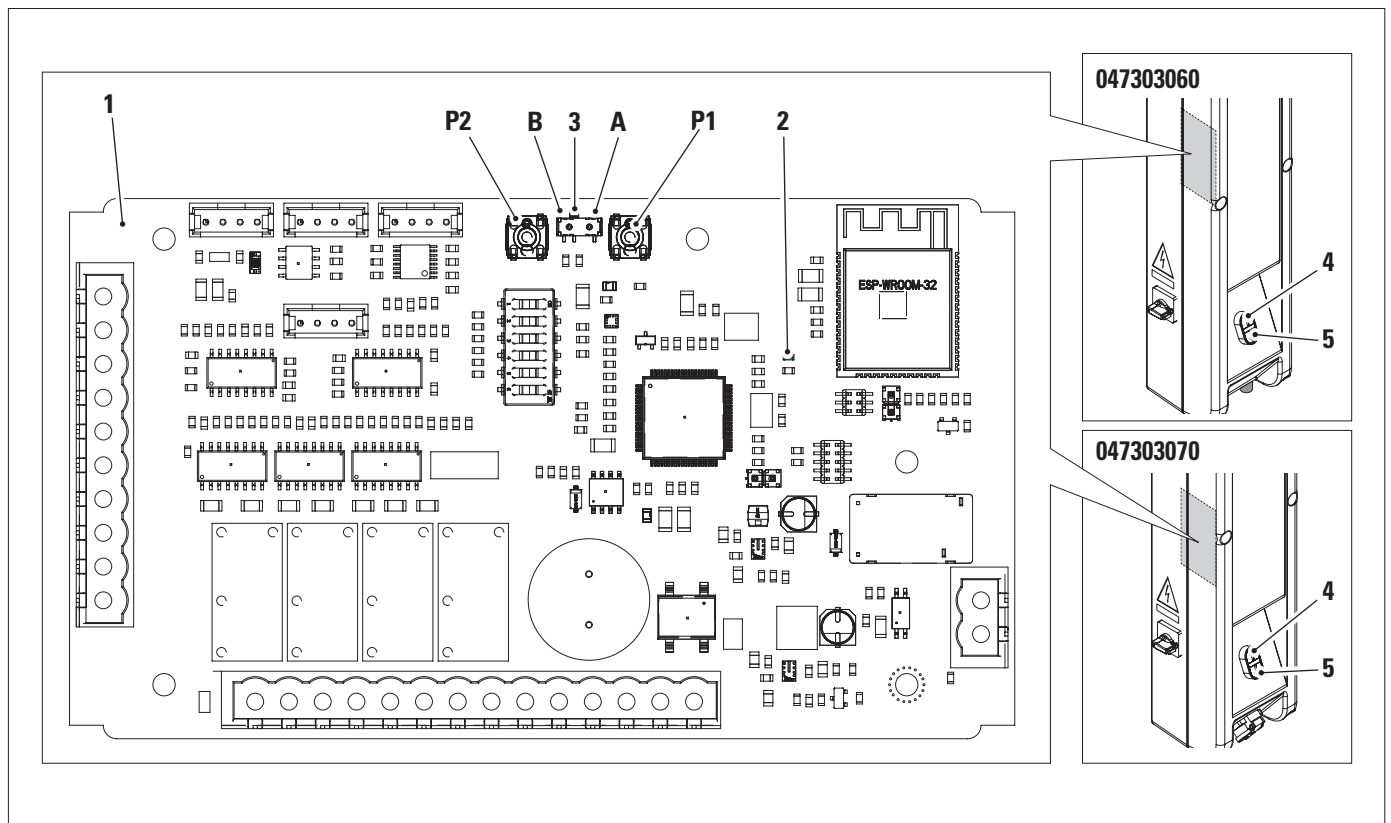

KAP. 9 SICHERHEITSEINRICHTUNGEN

Verriegelbarer Hauptschalter

Schalter Steuerkasten Art.-Nr. 047303060 - 047303070	
	<ul style="list-style-type: none"> • Stromkreis deaktiviert • Mit Vorhängeschloss verriegelte Position
	<ul style="list-style-type: none"> • Tasten deaktiviert • TEqLINK aktiviert • Mit Vorhängeschloss verriegelte Position

Totmann-System

Die Hebebühne ist mit dem "Totmann"-Betriebssystem ausgerüstet. Wird die Schalttaste losgelassen, werden die Hub- und Absenkbewegungen unverzüglich unterbrochen.

Mechanische Anschläge

Die Hebebühne ist mit mechanischen Anschlägen ausgestattet, die bei Endschalterstörungen am Ende des Aufwärts- oder Abwärtshubs aktiviert werden.

In solchen Situationen ist das der vorherigen Steuerung umgekehrte Manöver zu steuern, und zwar für einen Hub von 5-10 cm.

Den betroffenen Endschalter kontrollieren und ggf. austauschen.

Zusätzlich zu den oben erwähnten mechanischen Anschlägen kann es zu einer Unterbrechung des Temperaturfühlers des Motors kommen; letzterer wird nach etwa 3 Minuten automatisch wieder zurückgesetzt.

Gleichlaufregelung der Hubwagen



Alle eigenmächtigen Eingriffe oder Modifizierungen an Einrichtungen, die nicht zuvor vom Hersteller autorisiert wurden, entheben diesen von der Haftungsspflicht für dadurch verursachte Schäden.

Die Entfernung oder der Umbau der Sicherheitseinrichtungen stellt eine Verletzung der Europäischen Sicherheitsnormen dar.

Erreicht der Höhenunterschied der Hubwagen 18 mm greift automatisch die Überwachungsvorrichtung ein und stellt den Gleichlauf wieder her.

Not-Aus

Not-Aus-Abschaltung bei:

- Höhenunterschied zwischen den beiden Hubwagen über 40 mm;
- Motorenstopp;
- Bruch des Ausrichtungsdrahtseils.

Bei Not-Aus zugelassene Manöver

- Bei Not-Aus der Hebebühne (siehe obiger Abschnitt) darf diese über die Tasten weder hoch- noch heruntergefahren werden. Zur Wiederherstellung des Betriebs den Kundendienst zu Rate ziehen.
- Ist das Fahrzeug auf den Boden zu bringen, die Hubwagen manuell über die Riemenscheiben herunterfahren.

Stopp bei Tragmutterabnutzung

Wird die Hebebühne über die in KAP. 10.2 angegebene Grenze hinaus benutzt, greift die Tragmutterabnutzungs-Vorrichtung ein.

Das Gerät spricht an, wenn die Schlitten die Endanschläge der Senkung erreichen.

Dies wird vom Summer signalisiert, der wie folgt Modi aktiv ist: **1s ON** und **1s OFF**.

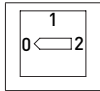
KAP. 10 WARTUNG

Bei Wartungsarbeiten den Hauptschalter auf 0 (Null) stellen.



Vorsicht: mechanische Elemente in Bewegung
Entfernung der Schutzabdeckungen auf eigene Gefahr des Bedieners.

10.1 WARTUNGSVORGANG

Alle 3 Monate eine regelmäßige Kontrolle der Sicherheitseinrichtungen durchführen.



Nach 10 Jahren Betrieb der Hebebühne ist eine Generalüberprüfung erforderlich, die von einem qualifizierten, vorzugsweise vom Hersteller autorisierten Techniker durchgeführt wird.

• MONATLICH

Tragende Schnecken - Die Schutzvorhänge entfernen, wenn die Wagen 50 cm vom Boden distanziert sind, und die Schnecken mit Hilfe der mitgelieferten Plättchens (1) kontrollieren: es muss wie abgebildet in die Nut eingefügt werden können; wenn die Seite STOP nicht positioniert werden kann, die Schnecke ersetzen.

• ALLE DREI MONATE

Gleitführungen - Die Gleitschuhführungen schmieren, indem Fett aufgetragen wird (Abb. B).

Lager - Die Motorabdeckungen abnehmen und Fett in die Schmiernippel (2) spritzen.

• JÄHRLICH

Schmierwannen - Die Schutzvorhänge entfernen und die Schmierwanne (3) mit Öl (ESSO GEAR OIL 85W-140 oder gleichwertigem) füllen.



Abb. A



Abb. B

Programmierter Wartungsplan

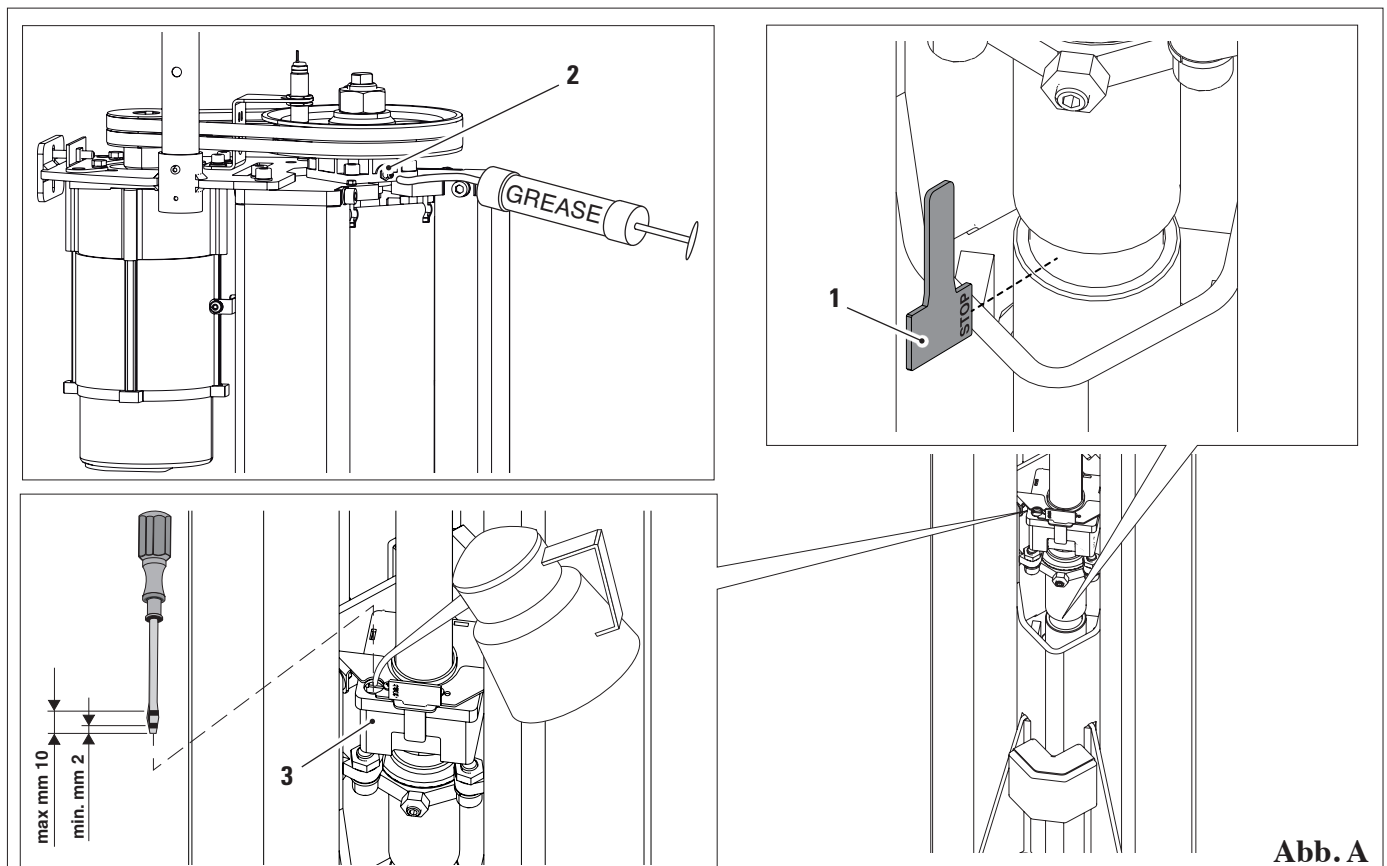
ZEITLICHE FÄLLIGKEIT	Art der WARTUNG	Plan der WARTUNG	POSITION*	KRITISCHER GRAD
TAG	AUFKLEBER	Beschädigte oder unleserliche Sicherheitsaufkleber kontrollieren und ggf. ersetzen	An Säule An Schalttafel	MITTEL
	ARME	Den Zustand des Fußschutzes, den Verschleiß oder die Beschädigung überprüfen und ggf. austauschen	Arme	MITTEL
	ARME	Den Zustand der Stempel, den Verschleiß oder die Beschädigung überprüfen und ggf. austauschen	Arme	GERING
MONAT	LAGER	Das tragende Lager der Schraube fetten (siehe aktuelle Angabe)	Am Kopf der Schraube	HOCH
	SCHNECKE	Den Zustand der Schraube, den Verschleiß oder Beschädigung überprüfen, ggf. austauschen (siehe aktuelle Angabe)	Oben am Schlitten	HOCH
	SCHNECKE	Den Ölstand in Schmierwanne überprüfen und ggf. Öl nachfüllen (siehe aktuelle Angabe)	Oben am Schlitten	HOCH
	SICHERHEITSSCHNECKE	Die Sicherheitsgegenschnecke mit Mehrzweckfett einfetten, KEIN Fett auf Feststoffbasis (Molicote), z. B. Graphit, verwenden.	Oben am Schlitten	MITTEL
QUARTAL	GLEITFÜHRUNGEN	Die Gleitführungen der Gleitschuhe der Schlitten mit Schmierfett schmieren (frei von Feststoffsuspensionen)		HOCH
	DÜBEL	Die Verankerung nach etwa zehn Hüben unter Vollast überprüfen, indem das Anzugsmoment der Dübel kontrolliert wird.	An Säule	HOCH
JAHR	RIEMEN	Die korrekte Riemenspannung und den Verschleiß überprüfen, ggf. spannen oder ersetzen	Oben an der Säule	HOCH
	SCHRAUBE	Überprüfen Sie den Zustand der Schraube, Abnutzung oder Beschädigung, ggf. austauschen	Im Inneren der Säule	HOCH
	ELEKTRONISCHE KOMPONENTEN	Überprüfen Sie den Zustand der elektrischen und elektronischen Komponenten, intakte Verbindungen und Schäden an Klemmenleisten oder Steckern	Schalttafel	HOCH
	LACKIERUNG	Kontrollieren Sie die lackierten Oberflächen auf Beschädigungen und Abschürfungen schleifen und streichen, falls erforderlich, um Rostschäden zu vermeiden	Schlitten-Säule	MITTEL
	SCHWEISSNÄHTE	Kontrollieren Sie die Schweißnähte an der Säule, am Schlitten und an den Armen auf Schäden und Risse. Falls erforderlich, den Bereich reinigen und die Schweißnaht wieder herstellen.	Schlitten-Säule	HOCH
	BEFESTIGUNGSSCHRAUBEN	Festigkeit aller Befestigungsschrauben prüfen Falls erforderlich, mit einem Drehmomentschlüssel anziehen.		
	ARME	1. Reinigen und schmieren Sie die Bolzen 2. die Federn der Bolzen kontrollieren und gegebenenfalls austauschen oder reparieren 3. kontrollieren, dass die Arme und Auszugsanschlüsse nicht beschädigt sind 4. das Armschlagsystem, die Gewinde und Verschleiß kontrollieren und ggf. ersetzen	Arme	MITTEL
	GLEITSCHUHE	Kontrollieren Sie die Gleitschuhe und Führungen auf Schäden und Verschleiß. Falls erforderlich, die Gleitschuhe austauschen und Passscheiben unterlegen, den Bereich reinigen und schmieren	Schlitten	MITTEL

10.2 SCHNECKENVERSCHLEISS UND ERSATZ DER SCHRAUBENEINHEIT

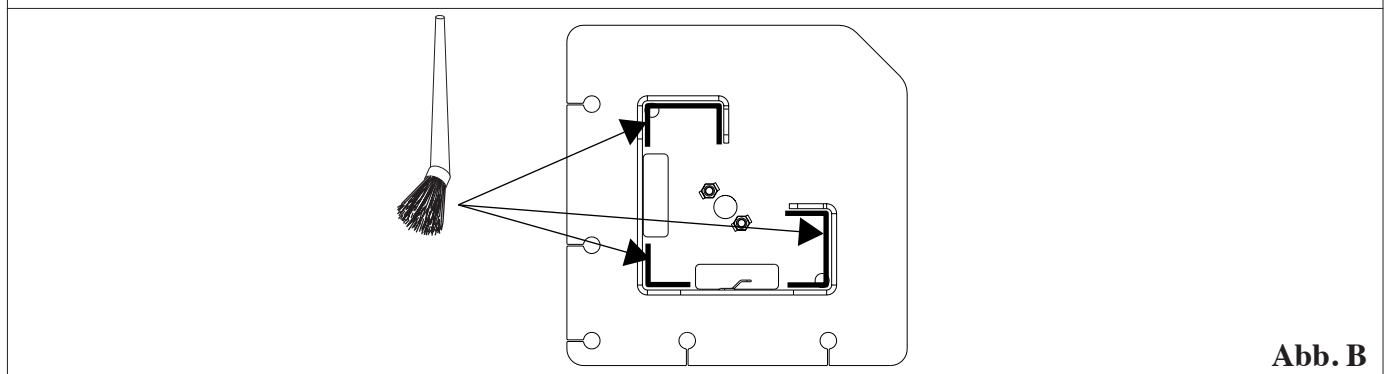

Der Verschleiß der tragenden Schnecke führt zum ihrem Bruch; in diesem Fall wird sich der Schlitten um 20 mm senken. Diese Bedingung wird von der elektronischen Platine erfasst, wenn die Endschalter des Senkhubs aktiviert werden, was durch die akustische Warnvorrichtung im 1 Sekunden-Modus signalisiert wird. ON - 1 Sek. OFF. Infolgedessen kann das Hubmanöver nicht ausgeführt werden. Ein Bruch der Schnecke erfordert den Austausch der gesamten Schraubeneinheit.

Verfahren für den Austausch der Schraubeneinheit:

- Den Schlitten auf eine Höhe von ca. 350 mm bringen und einen Holzklötz (1) unter den Schlitten einfügen.
- Die Maschine von der Spannungsversorgung trennen.
- Den Schutzvorhand (2) abnehmen.
- Die Abdeckungen (3) abmontieren.
- Die Halterung des Näherungsschalters (4) entfernen (Achtung: nicht den Näherungsschalter aus seiner Halterung).
- Die Antriebsriemen (5) abnehmen.
- Die Riemenscheibe so weit drehen, bis der Schlitten den Holzklötz (Abb. C) berührt.
- Den Drehschutz der Wanne (6) ausbauen.
- Den Stift und die Mutter (7) lösen und entfernen.
- Die Halteschrauben (8) lösen und entfernen.
- Die Schrauben des Lagerhalters (9) lösen und entfernen.
- Die Schnecke drehen, bis sie mit der Sicherheitsschnecke in Berührung kommt (im Uhrzeigersinn) (10).
- Die Ringschraube am Ende der Schraube (11) anschrauben.
- Die Schraubeneinheit von der Innenseite der Hebebühne (Abb. D) mit einer diagonalen Bewegung entfernen.
- Diese Schritte in umgekehrter Richtung ausführen, um das Ersatzteil zu montieren (dabei insbesondere auf die Befestigung des Stifts achten).
- Das RESET vornehmen, siehe Kapitel 8.5.

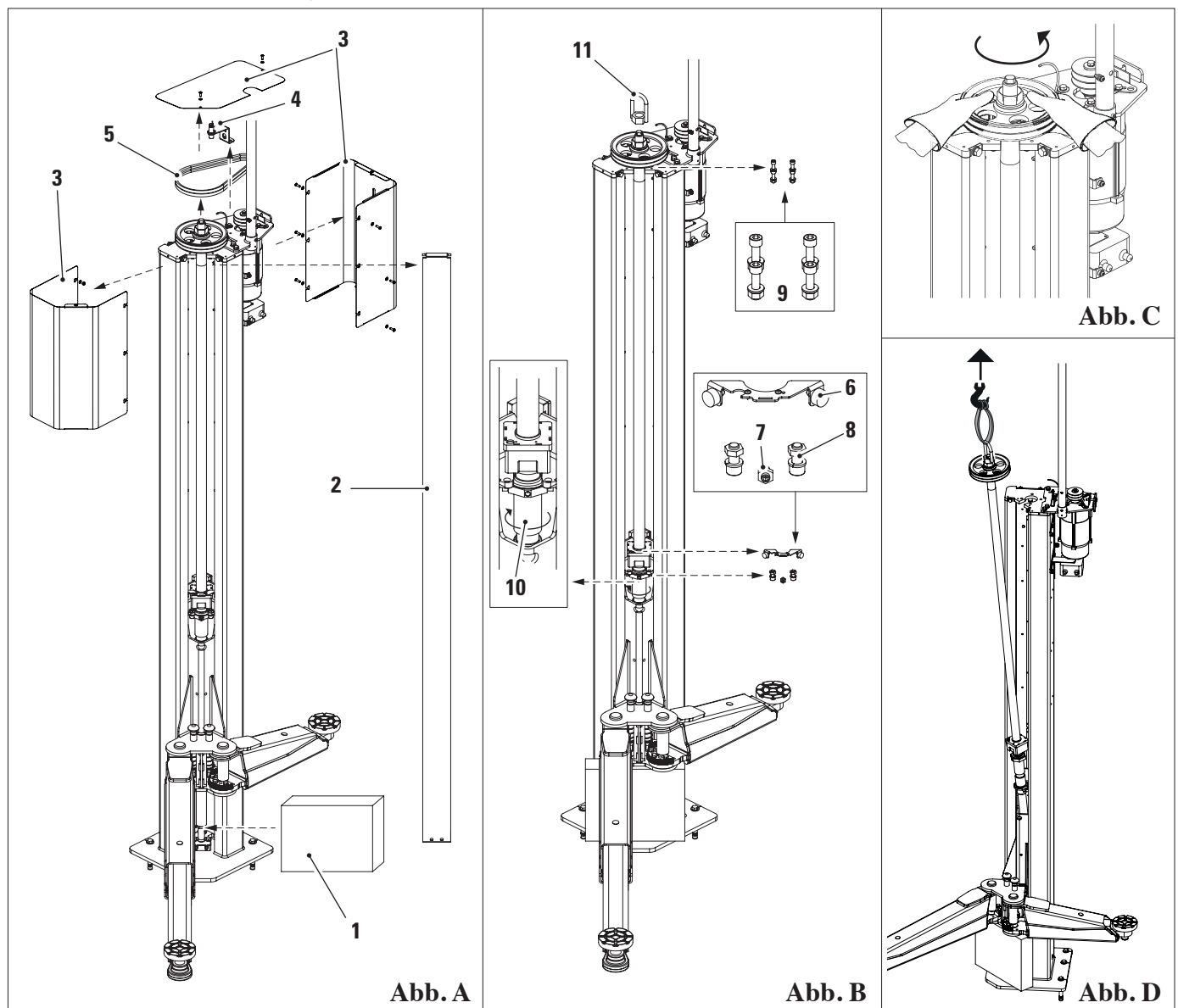

10.3 BETRIEBSSTÖRUNGEN

Nachstehend einige der Betriebsstörungen, die während der Bedienung der Hebebühne auftreten könnten. ROTARY übernimmt in keinem Fall die Haftung für eventuelle durch Eingriffe seitens nicht autorisiertem Personal verursachte Schäden an Personen, Tieren oder Sachen. Bei Betriebsstörungen unverzüglich den technischen Kundendienst zu Rate ziehen, damit Anweisungen zur Ausführung der Eingriffe und/oder Einstellungen unter Berücksichtigung der notwendigen Sicherheitsmassnahmen, damit weder für Personen, Tiere noch Sachen Gefahr besteht, erteilt werden können.



Muss durch den technischen Kundendienst ausgeführt werden. Eingriff verboten.

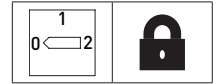

STÖRUNG	URSACHE	BESEITIGUNG
Kein Betrieb Summer aus.	Versorgungsspannung.	Die Spannung in den Versorgungskabeln kontrollieren. Den Schalter / Wechselrichter der Hebebühne kontrollieren. Leitungssicherungen kontrollieren. Transformator der Steuerungen und seine Sicherungen kontrollieren.
Der Hub wird nicht abgeschlossen. Summer aus.	Thermosensor des Motors schaltet ab.	Rücksetzung abwarten.
Kein Betrieb Summer ein.	Hebebühne in Not-Aus. Näherungsschalter. Motor steht.	Siehe Kapitel 8.5. Einstellen/Ersetzen. Motorriemen kontrollieren.
Kein Betrieb. Summer ein: 2 Sek. ON / 2 Sek. OFF	Den Kartenschalter nach dem Zurücksetzen der Sperre auf manuell stellen.	Schalter auf automatisch stellen.
Hebt die Schlitten am Ende des Abwärtshubs nicht an. Summer ein: 1 Sek. ON / 1 Sek. OFF	Sperre aufgrund von Schneckenabnutzung.	Siehe Kapitel 10.2.
Kein Betrieb, auch nicht im manuellen Modus. Summer ein.	Sicherheitssperre.	Siehe Kapitel 8.5.

KAP. 11 ENTSORGUNG - VERSCHROTTUNG

11.1 DEMONTAGE

Demontagarbeiten dürfen nur von autorisiertem Fachpersonal durchgeführt werden. Nur qualifizierte Elektriker dürfen an der elektrischen Anlage arbeiten.

1. Schalten Sie das Gerät vor der Demontage über den Hauptschalter (Stellung OFF) aus.
2. Trennen Sie die Stromversorgung.
3. Entleeren Sie den Öltank. Entsorgen Sie Hydrauliköl und Betriebsflüssigkeiten wie im Kapitel 11.3 beschrieben.
4. Entfernen Sie Fett und andere Chemikalien. Entsorgen sie wie in Kapitel 11.3 beschrieben
5. Die Demontage muss in umgekehrter Reihenfolge wie die Montage erfolgen (siehe Kapitel 7).

11.2 EINLAGERUNG

- Soll die Hebebühne über längere Zeit eingelagert werden, ist sie von den Versorgungsanschlüssen zu trennen. Die Behälter, in denen die Betriebsflüssigkeit enthalten ist entleeren und alle Teile schützen, die durch Staubablagerungen beschädigt werden könnten.
- Teile, die durch Austrocknen beschädigt werden könnten, sind zu schmieren.
- Bei der Wiederaufnahme des Betriebs die im Ersatzteilverzeichnis aufgeführten Dichtungen ersetzen.

11.3 ENTSORGUNG

Umweltgerechte Verfahren für die Entsorgung

Vermeiden Sie Umweltgefahren.

Vermeiden Sie den Kontakt mit oder das Einatmen von giftigen Substanzen wie Hydraulikflüssigkeit. Öle und Schmierstoffe sind wassergefährdende Stoffe im Sinne des WGH-Wasserwirtschaftsgesetzes. Entsorgen Sie diese immer auf eine umweltfreundliche Weise und gemäß den Vorschriften Ihres Landes. Hydrauliköl auf Mineralölbasis ist wassergefährdend und brennbar. Bitte beachten Sie das Sicherheitsdatenblatt bei der Entsorgung. Achten Sie darauf, dass kein Hydrauliköl, Schmiermittel oder Reinigungsmittel den Boden verunreinigt oder in die Kanalisation gelangt.

Verpackung

Nicht über den Hausmüll entsorgen! Die Verpackung enthält einige recycelbare Materialien, die nicht über den Hausmüll entsorgt werden dürfen.

1. Entsorgen Sie das Verpackungsmaterial in Übereinstimmung mit den örtlichen Vorschriften.

Öle, Fette und andere Chemikalien.

1. Bei der Arbeit mit Ölen, Fetten und anderen Chemikalien sind die für das jeweilige Produkt geltenden Umweltvorschriften zu beachten.
2. Entsorgen Sie Öl, Fett und andere Chemikalien in Übereinstimmung mit den in Ihrem Land geltenden Umweltvorschriften.

Metalle / Elektronikschrott

Diese müssen stets von einem zertifizierten Unternehmen ordnungsgemäß entsorgt werden.

INSTALLATIONSBERICHT

KONTROLLOPERATION
DURCH DEN MONTEUR AUSZUFÜLLEN

Hebebühne Modell _____

Serie-Nr. _____

Kontrolle der Bodenidoneität	<input type="checkbox"/>
Kontrolle Anschlussspannung	<input type="checkbox"/>
Hauptschalter	<input type="checkbox"/>
Steuerung Heben und Senken	<input type="checkbox"/>
Einwandfreie Bewegung des Hubwagens - Antriebssteuerung	<input type="checkbox"/>
Kontrolle Funktionstüchtigkeit Absenkenschalter	<input type="checkbox"/>
Kontrolle des Anzugsmoments der Dübel	<input type="checkbox"/>
Kontrolle einwandfreies Gleiten der Teleskoparme	<input type="checkbox"/>
Kontrolle einwandfreies Ein- und Ausklinken der Armarretierungen	<input type="checkbox"/>
Kontrolle Stand Schmiervorrichtung der Spindel	<input type="checkbox"/>
Kontrolle Schmierung der Gleitführungen	<input type="checkbox"/>
Kontrolle Vorhandensein und Anbringung der Kleber	<input type="checkbox"/>
Tragfähigkeit	<input type="checkbox"/>
Hinweise	<input type="checkbox"/>
Serie-Nr.	<input type="checkbox"/>

Unterschrift und Stempel des Monteurs

Datum der Installatiom

PERIODISCHER KUNDENBESUCH

Kontrolloperation	Datum	Unterschrift	Datum	Unterschrift	Datum	Unterschrift	Datum	Unterschrift
	Kontrolle Stand Tragmutterverschleiss	<input type="checkbox"/>		<input type="checkbox"/>		<input type="checkbox"/>		<input type="checkbox"/>
Hauptschalter	<input type="checkbox"/>		<input type="checkbox"/>		<input type="checkbox"/>		<input type="checkbox"/>	
Steuerung Heben und Senken	<input type="checkbox"/>		<input type="checkbox"/>		<input type="checkbox"/>		<input type="checkbox"/>	
Kontrolle Funktionstüchtigkeit Absenkenschalter	<input type="checkbox"/>		<input type="checkbox"/>		<input type="checkbox"/>		<input type="checkbox"/>	
Kontrolle des Anzugmoments der Dübel	<input type="checkbox"/>		<input type="checkbox"/>		<input type="checkbox"/>		<input type="checkbox"/>	
Kontrolle einwandfreies Gleiten der Teleskoparme	<input type="checkbox"/>		<input type="checkbox"/>		<input type="checkbox"/>		<input type="checkbox"/>	
Kontrolle einwandfreies Ein- und Ausklinken der Armarretierungen	<input type="checkbox"/>		<input type="checkbox"/>		<input type="checkbox"/>		<input type="checkbox"/>	
Kontrolle Stand Schmiervorrichtung der Spindel	<input type="checkbox"/>		<input type="checkbox"/>		<input type="checkbox"/>		<input type="checkbox"/>	
Kontrolle Schmierung der Gleitführungen	<input type="checkbox"/>		<input type="checkbox"/>		<input type="checkbox"/>		<input type="checkbox"/>	
Kontrolle Vorhandensein und Anbringung der Kleber	<input type="checkbox"/>		<input type="checkbox"/>		<input type="checkbox"/>		<input type="checkbox"/>	
Integritätskontrolle der Hebeanlaufstopfen	<input type="checkbox"/>		<input type="checkbox"/>		<input type="checkbox"/>		<input type="checkbox"/>	
Tragfähigkeit	<input type="checkbox"/>		<input type="checkbox"/>		<input type="checkbox"/>		<input type="checkbox"/>	
Hinweise	<input type="checkbox"/>		<input type="checkbox"/>		<input type="checkbox"/>		<input type="checkbox"/>	
Serie-Nr.	<input type="checkbox"/>		<input type="checkbox"/>		<input type="checkbox"/>		<input type="checkbox"/>	

INDEX

CH. 1	SYMBOLS USED IN THE MANUAL	EN_2
CH. 2	INTRODUCTION	EN_3
2.1	DESCRIPTION OF LIFT.....	EN_3
2.2	INTENDED USE.....	EN_3
CH. 3	TECHNICAL DETAILS	EN_4
3.1	MAIN TECHNICAL SPECIFICATIONS.....	EN_4
3.2	GENERAL TECHNICAL DETAILS.....	EN_5
3.3	MACHINE IDENTIFICATION DATA.....	EN_7
3.4	MAIN CONTROLS OF THE LIFT.....	EN_8
3.5.	ELECTRICAL INSTALLATION.....	EN_9
CH. 4	GENERAL SAFETY PRECAUTIONS	EN_17
4.1	INDICATION OF OUTSTANDING RISKS.....	EN_17
4.2	SAFETY PLATES AND/OR STICKERS.....	EN_17
4.3	STAFF TRAINING.....	EN_17
4.4	SUITABILITY FOR USE.....	EN_17
CH. 5	INSTALLATION REQUIREMENTS	EN_18
5.1	MINIMUM REQUIREMENTS FOR THE PLACE OF INSTALLATION.....	EN_18
5.2	FLOORING REQUIREMENTS.....	EN_19
CH. 6	PRE-INSTALLATION AND MOVEMENT	EN_20
CH. 7	INSTALLATION	EN_21
7.1	BLOCKS.....	EN_21
7.2	CONCRETE.....	EN_21
7.3	INSTALLATION INSTRUCTIONS.....	EN_22
7.4	VOLTAGE CHECK.....	EN_23
7.5	CONNECTING UP TO THE MAINS.....	EN_23
7.6	CONNECTIONS.....	EN_23
7.7	COMPLETION AND CHECK.....	EN_24
7.8	ARM FITTING.....	EN_25
7.9	USE OF ACCESSORIES.....	EN_25
CH. 8	USING THE LIFT	EN_26
8.1	IMPORTANT CHECKS TO BE MADE.....	EN_26
8.2	HANDLING AND BEHAVIOUR DURING LIFT OPERATION.....	EN_26
8.3	DESCRIPTION AND FUNCTION OF CONTROLS.....	EN_27
8.4	IMPROPER USE OF THE LIFT.....	EN_28
8.5	SYNCHRONISATION CONTROL DEVICE OPERATION.....	EN_29
CH. 9	SAFETY DEVICES	EN_31
CH. 10	MAINTENANCE	EN_32
10.1	MAINTENANCE ACTIVITIES.....	EN_32
10.2	NUT WEAR AND REPLACEMENT OF SCREW ASSEMBLY.....	EN_34
10.3	TROUBLE SHOOTING.....	EN_35
CH. 11	WASTE DISPOSAL-DISMANTLING	EN_35
11.1	DISASSEMBLING.....	EN_35
11.2	STORAGE.....	EN_35
11.3	WASTE DISPOSAL.....	EN_35
	INSTALLATION REPORT	EN_36
	PERIODICAL VISIT	EN_37
	UNSCHEDULED MAINTENANCE AND REPAIRING	EN_38

CAUTION!

- This manual is an integral part of the product and must be kept together with the lift throughout its lifetime.
- Therefore, store it in a known and readily available place so as to refer to it any time doubts arise.
- Only suitably trained personnel who have read and understood this manual may use the lift.
- Any damage resulting from improper use of the lift and failure to follow the instructions contained in this manual will release ROTARY from any liability.

CH. 1 SYMBOLS USED IN THE MANUAL

	Caution!		It is mandatory to consult the manual/ instruction booklet
	Electrical hazard		Specialist staff
	Danger of suspended loads		Obligation
	Danger fork-lift trucks and other industrial vehicles		Passing and standing under suspended loads is prohibited
	Danger of moving parts		Use protective shoes
	Danger of crushing hands		Use gloves
	Lifting from above		Wear protective clothing
	Prohibited		Use goggles
			It must be disconnected before maintenance or repairs

CH. 2 INTRODUCTION

2.1 DESCRIPTION OF LIFT

- Product name: CAR LIFT
- Product description: Electromechanical lift with two posts and telescopic arms.
Chassis-level lift

2.2 INTENDED USE

The product is intended for lifting motor vehicles in accordance with current legislation, Machinery Directive 2006/42/EC; the load capacity is as indicated on the serial number plate.

The lift is designed for indoor use not subject to the action of wind.

Vehicles having the following characteristics may be lifted:

- the weight must not exceed the lift capacity (see fig. **A**) as required by the UNI EN 1493:2010 standard
- the lift complies with the 2/5 - 3/5 load distribution and reversibility condition expressed by 1493:2010 (fig. **B**).
- minimum distance of pickup points: mm.1000 (Fig. **C**).

For lower distance values, the lift capacity will be reduced. In this case or in other cases not covered by this manual, the manufacturer should be contacted.

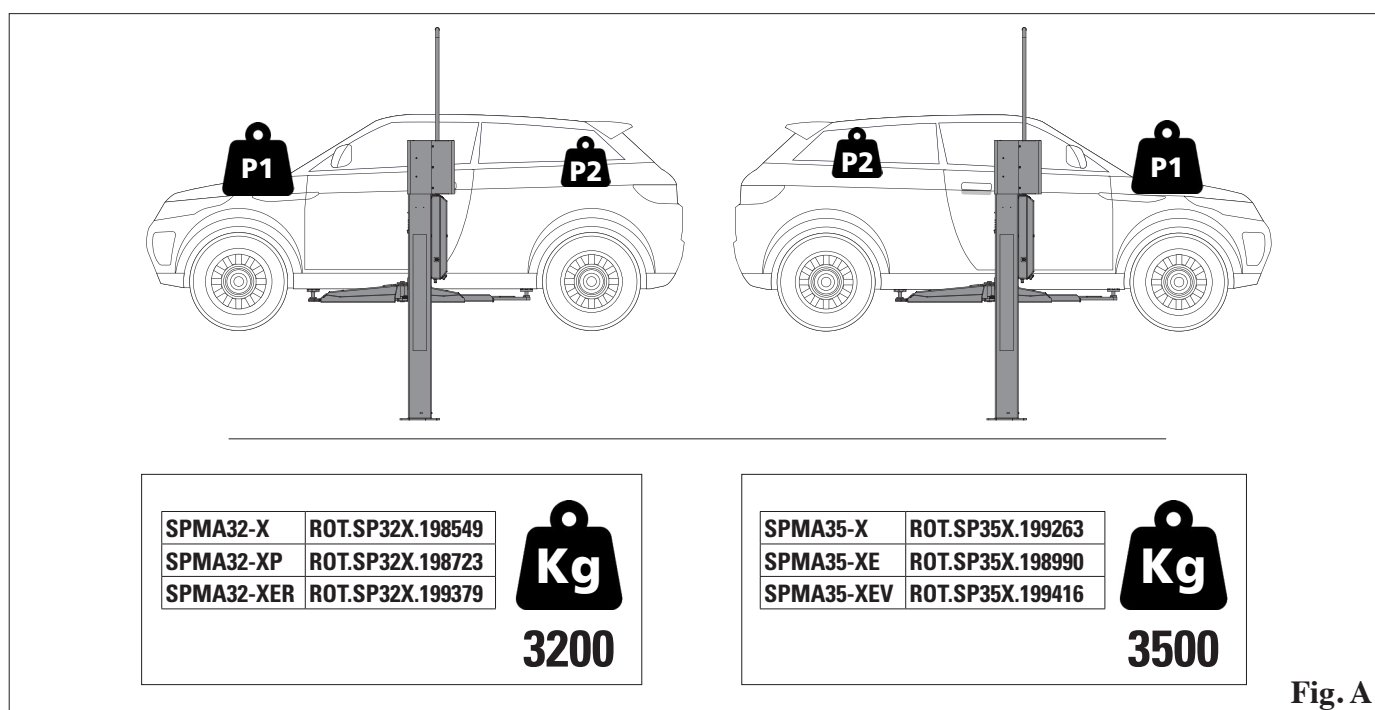
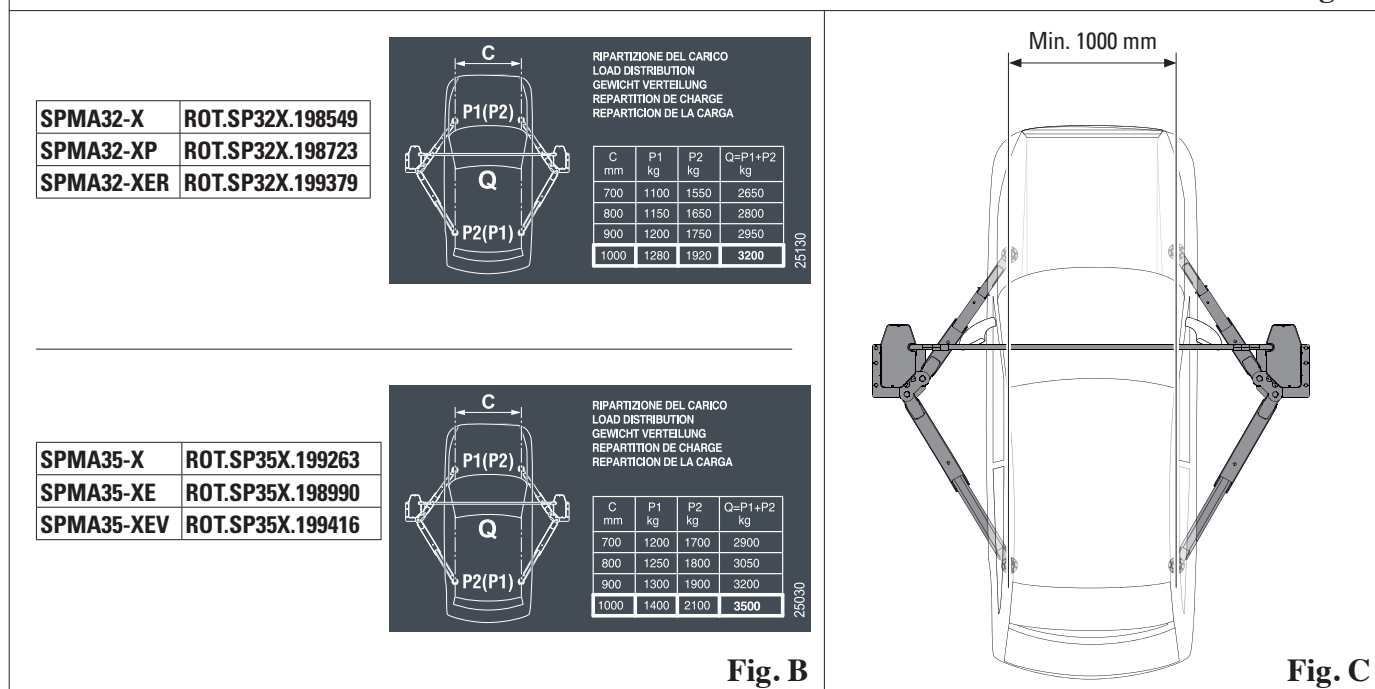
Fig. A

Fig. B
Fig. C

CH. 3 TECHNICAL DETAILS

3.1 MAIN TECHNICAL SPECIFICATIONS

Carriage translation on high strength, low friction coefficient technopolymer sliding shoes.

Lifting and lowering movements obtained by means of bronze bearing nuts coupled with fine pitch actuator screws to guarantee movements cannot be reversed.

Electronic safety device to prevent further lifting movements in the event of complete wear of the bearing nut.

Automatic lubrication of the actuator screws at each stroke.

Carriage realignment by electronic device.

Locking device for misalignment of carriages exceeding **30 mm**.

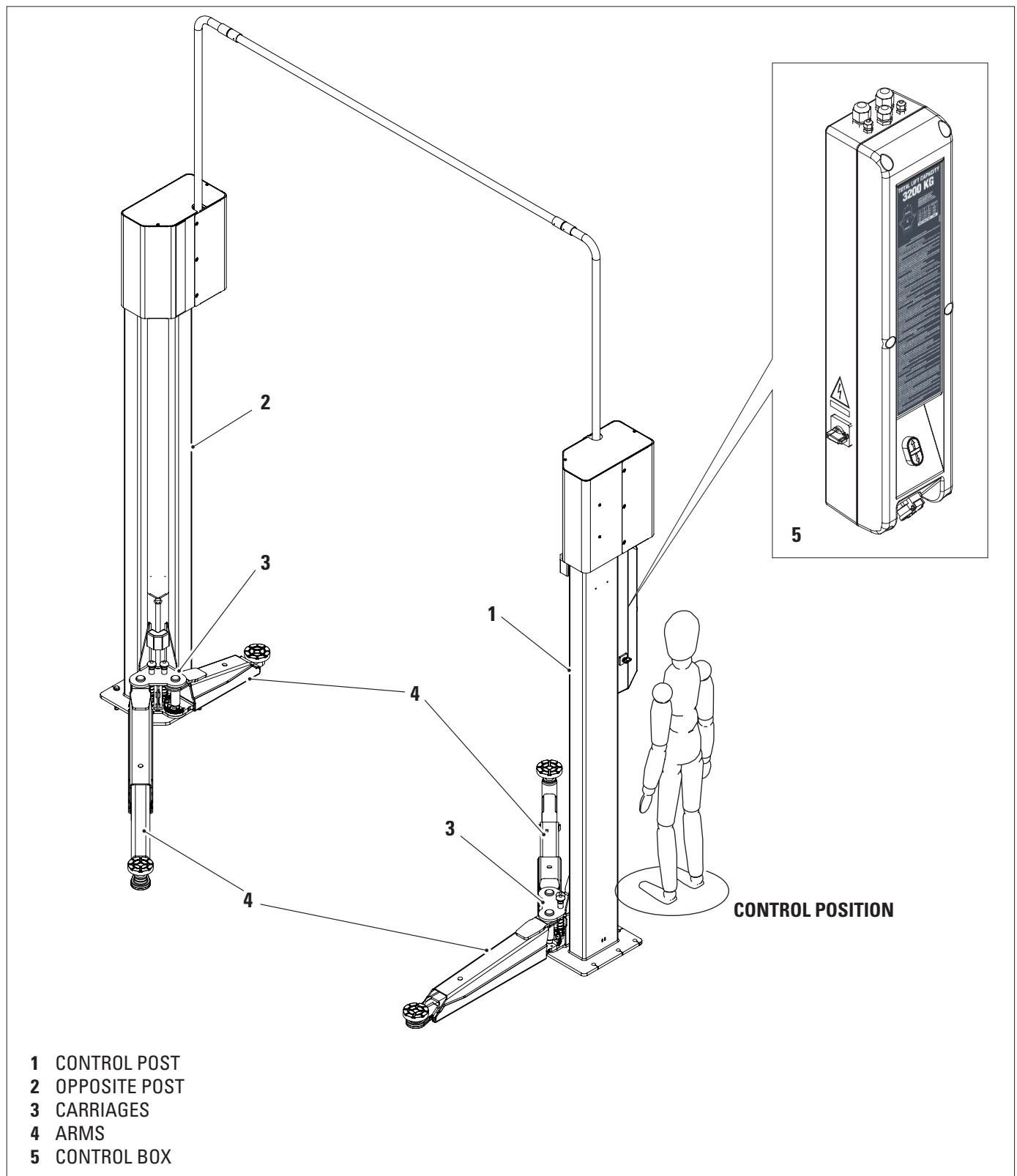

3.2 GENERAL TECHNICAL DETAILS
SPMA32

Number of columns	2	D Drive-Thru	2472 mm	Lifting height max.	2000 mm
Lifting Capacity	3200 kg	Front Arm Min	555 mm	Rise	1860 mm
Required ceiling height	4150 mm	Front Arm Max	1100 mm	Lifting/lowering time	42 secs.
A Height overall	4052 mm	Rear Arm Min	805 mm	Power supply	400 V 50 Hz 3Ph
B Outside columns	3223 mm	Rear Arm Max	1200 mm	Driving power	2x2.6 Kw
C Inside columns	2700 mm	E Max. pad Height	130 mm		
		F Min. pad Height	96 mm		

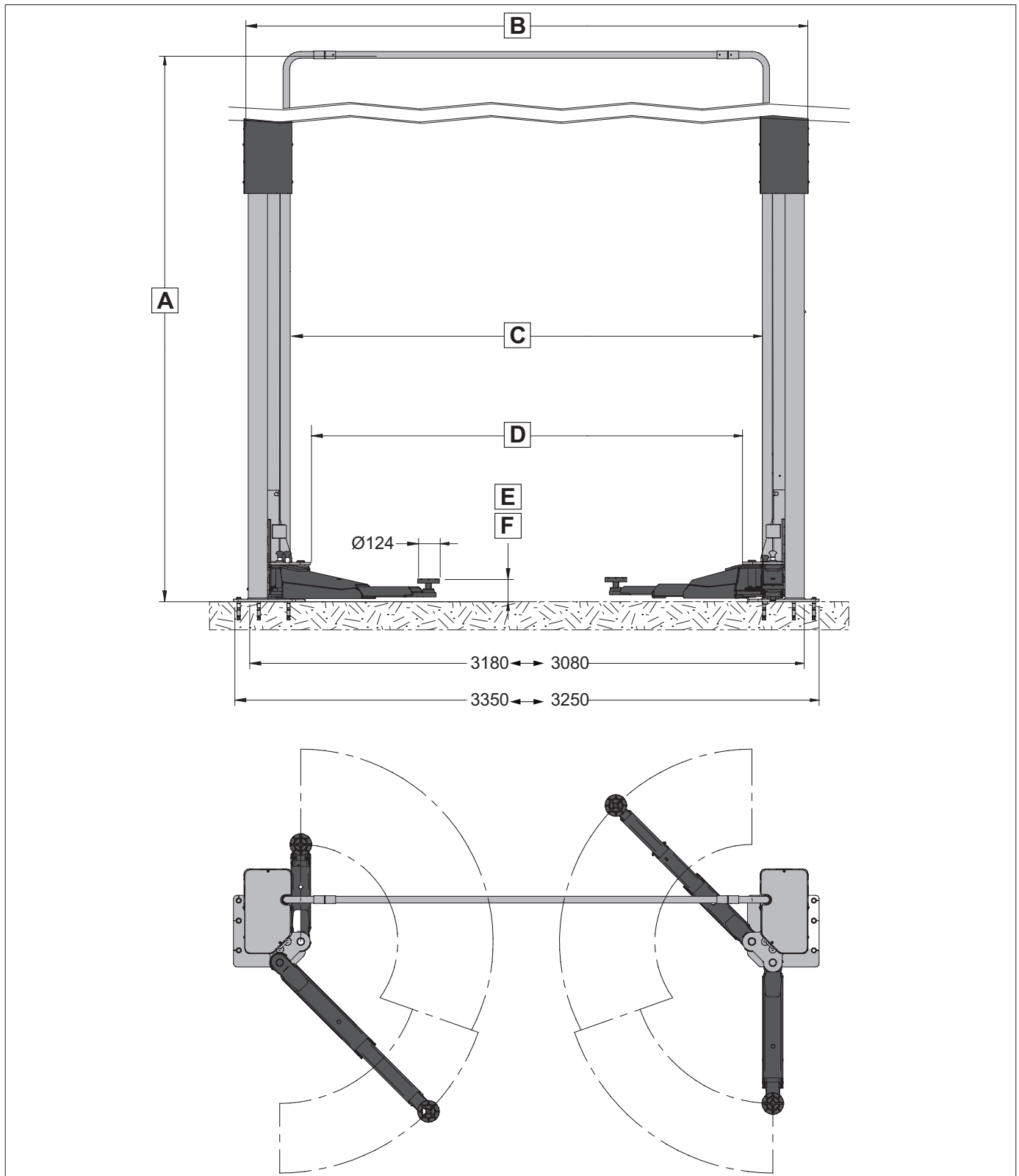

SPMA35

Number of columns	2
Lifting Capacity	3500 kg
Required ceiling height	4150 mm
A Height overall	4052 mm
B Outside columns	3223 mm
C Inside columns	2700 mm

D Drive-Thru	2472 mm
Front Arm Min	564 mm
Front Arm Max	1160 mm
Rear Arm Min	922 mm
Rear Arm Max	1460 mm
E Max. pad Height	150 mm
F Min. pad Height	100 mm

Lifting height max.	2012 mm
Rise	1863 mm
Lifting/lowering time	42 secs.
Power supply	400 V 50 Hz 3Ph
Driving power	2x2.6 Kw

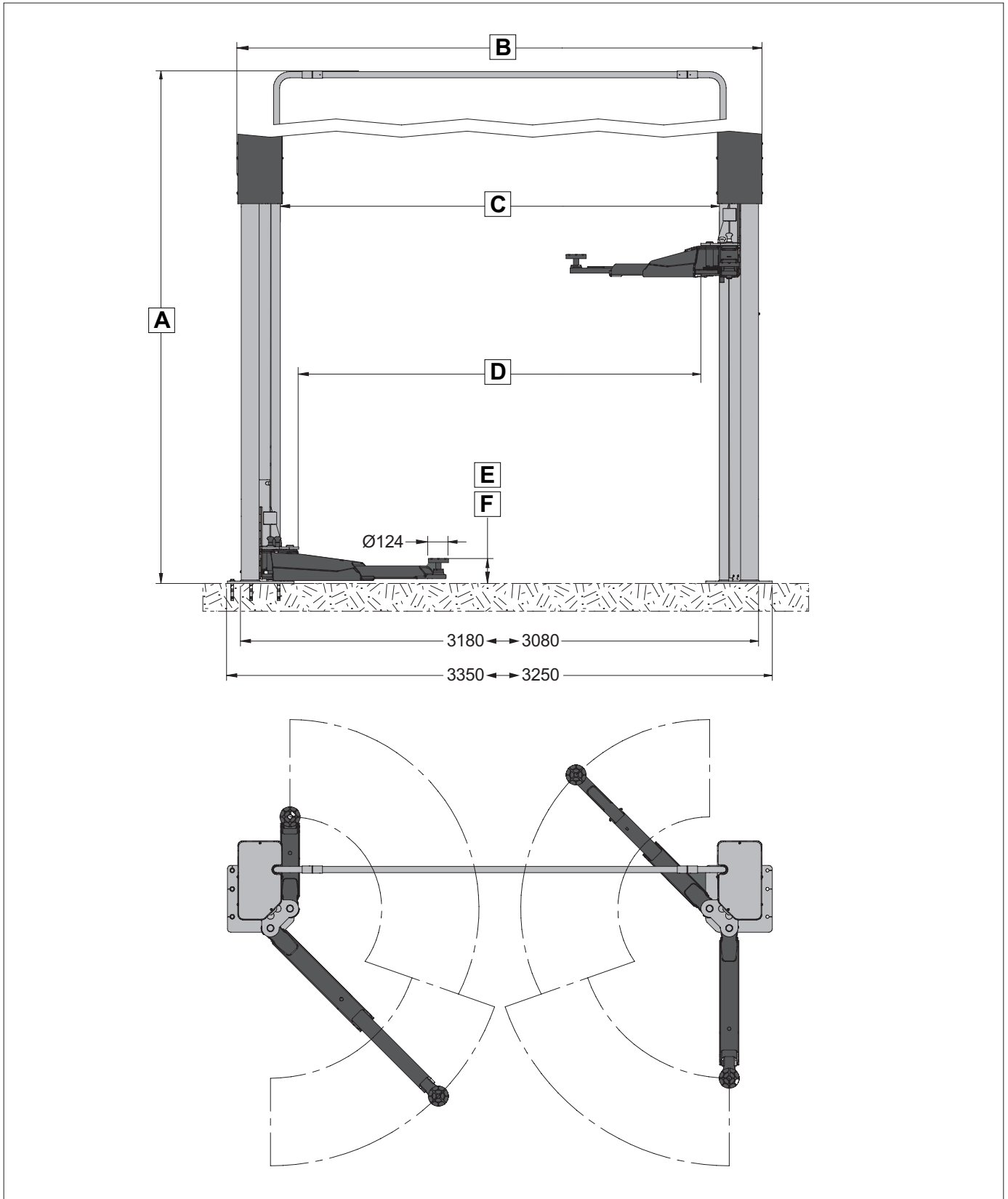

PHONOMETRIC DATA
NOISE LEVEL

	Ref	Distance (m)	Lp dB(A)	Lpk dB(C)	U dB
	1	0,6	I 70dB(A)	I 130dB(C)	
2	1,0	73	I 130dB(C)		

3.3 MACHINE IDENTIFICATION DATA

The lift identification plate on the control column trailer contains the following data:

- A** Manufacteur
- B** Capacity lift
- C** Serial number
- D** Year of manufacture
- E** Model

CAUTION: Do not tamper with, carve, change or remove the identification plate; do not cover it with panels, etc., since it must always be visible.

Said plate must always be kept clean.

WARNING: Should the plate be accidentally damaged (removed from the machine, damaged or even partially illegible) inform immediately the manufacturer.

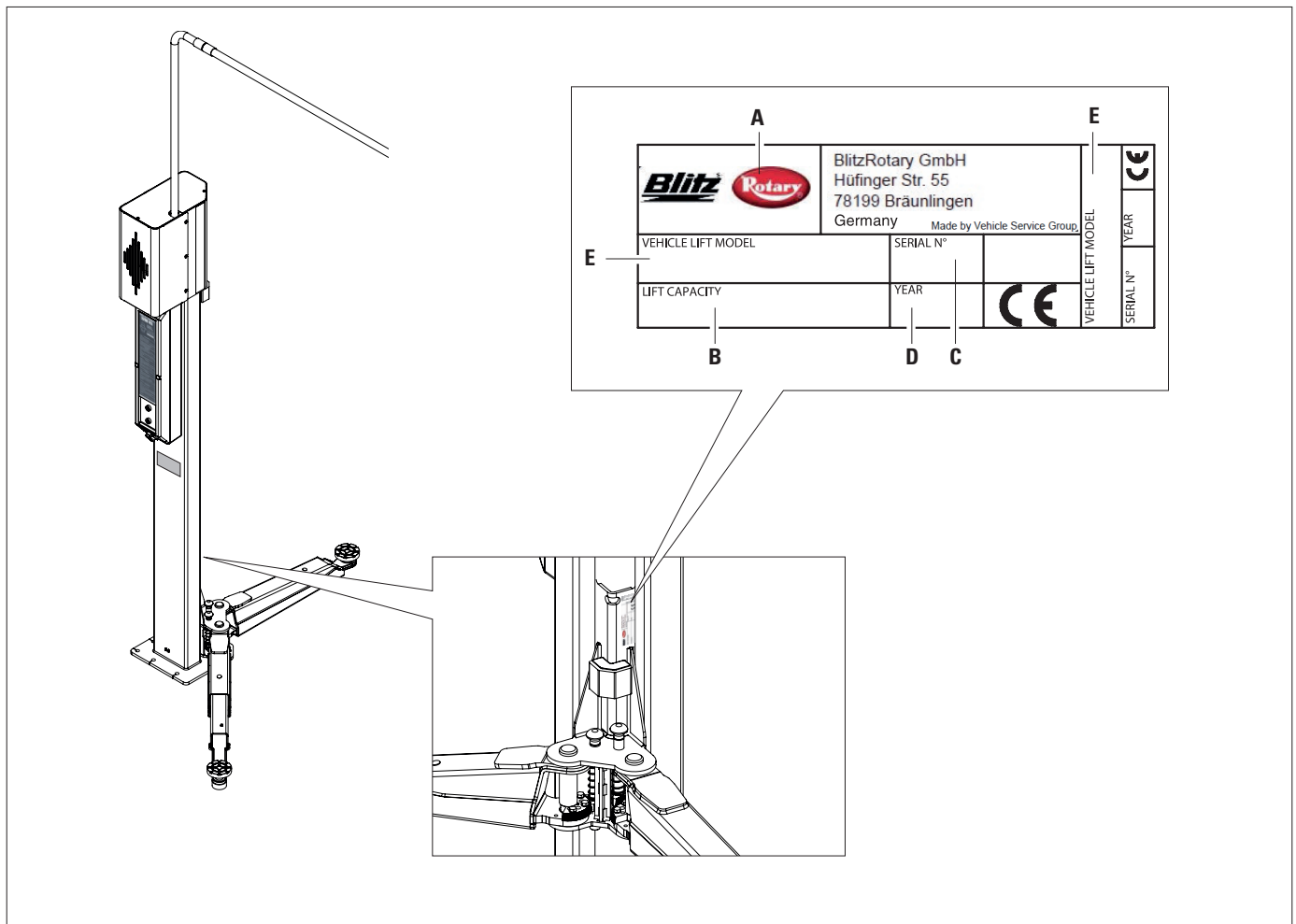

3.4 MAIN CONTROLS OF THE LIFT

The main controls are located in the control box, which changes according to the model. Refer to comparison diagram.

MODEL	PN CODE	CONTROL BOX PART NO.	JUNCTION BOX PART NO.	ELECTRICAL SYSTEM PART NO.
SPMA32-X	ROT.SP32X.198549	047303060	047303021	047305510
SPMA32-XP	ROT.SP32X.198723	047303070	047303080 (control box)	047305530
SPMA32-XER	ROT.SP32X.199379	047303070	047303080 (control box)	047305530
SPMA35-X	ROT.SP35X.199263	047303060	047303021	047305510
SPMA35-XE	ROT.SP35X.198990	047303070	047303080 (control box)	047305530
SPMA35-XEV	ROT.SP35X.199416	047303070	047303080 (control box)	047305530

047303060

Control box with switch and up/down push-buttons.

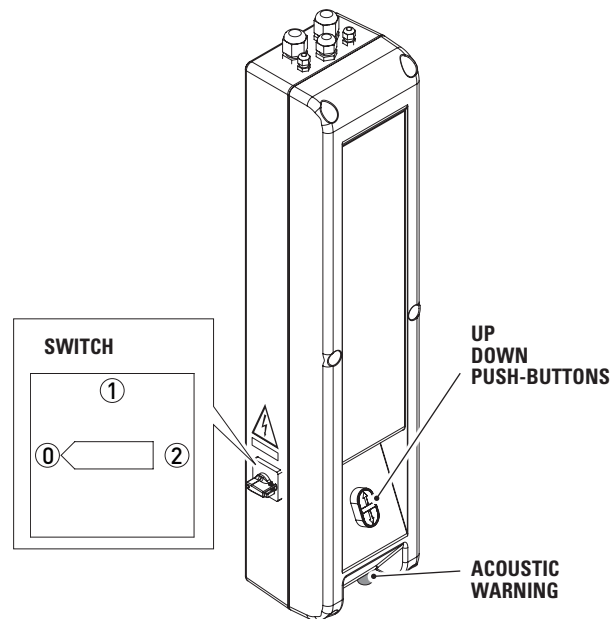
047303070 / 047303080

Double control box with switch, up and down push-buttons, emergency button.

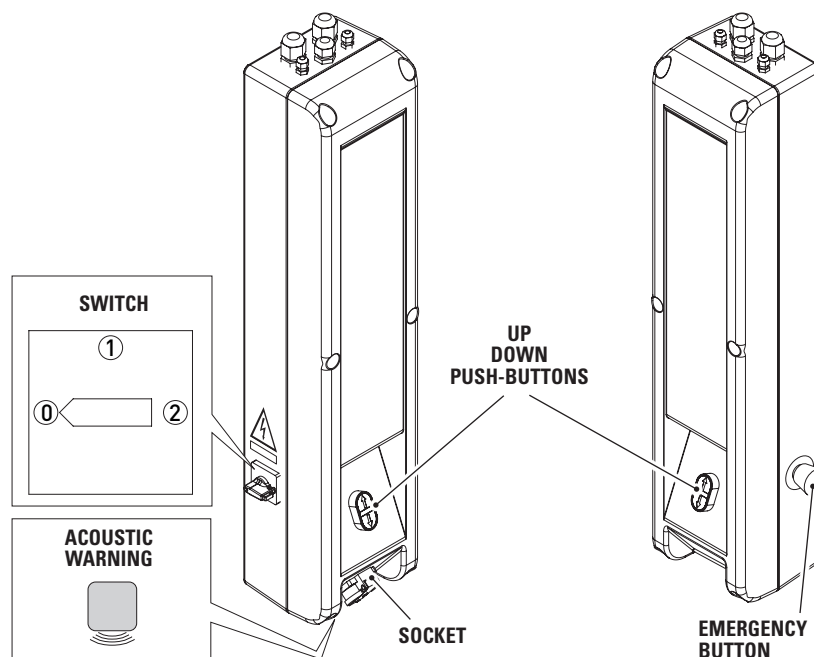

3.5. ELECTRICAL INSTALLATION

Power installations must be made by the user

ELECTRICAL SYSTEM PART NO: 047305510

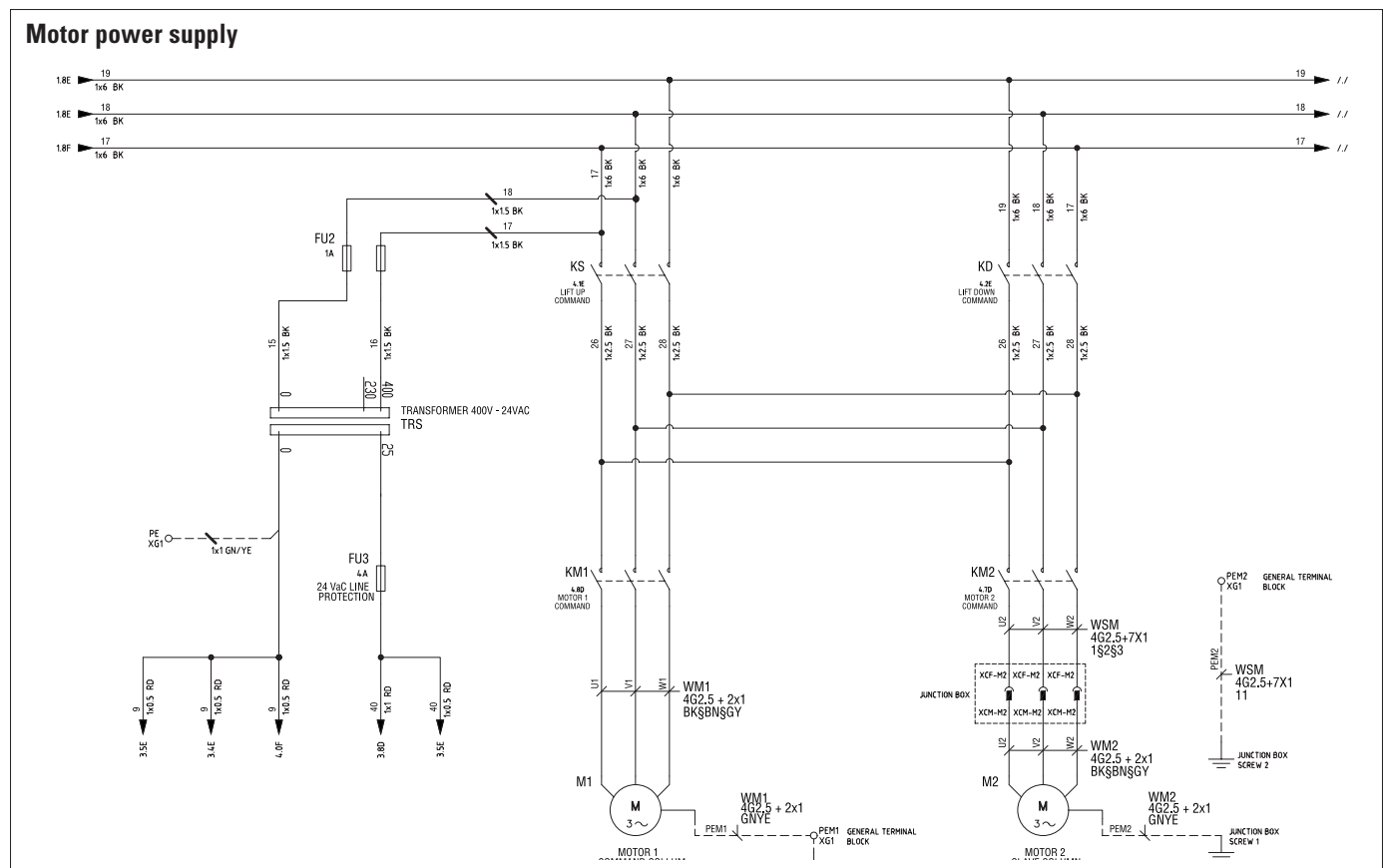
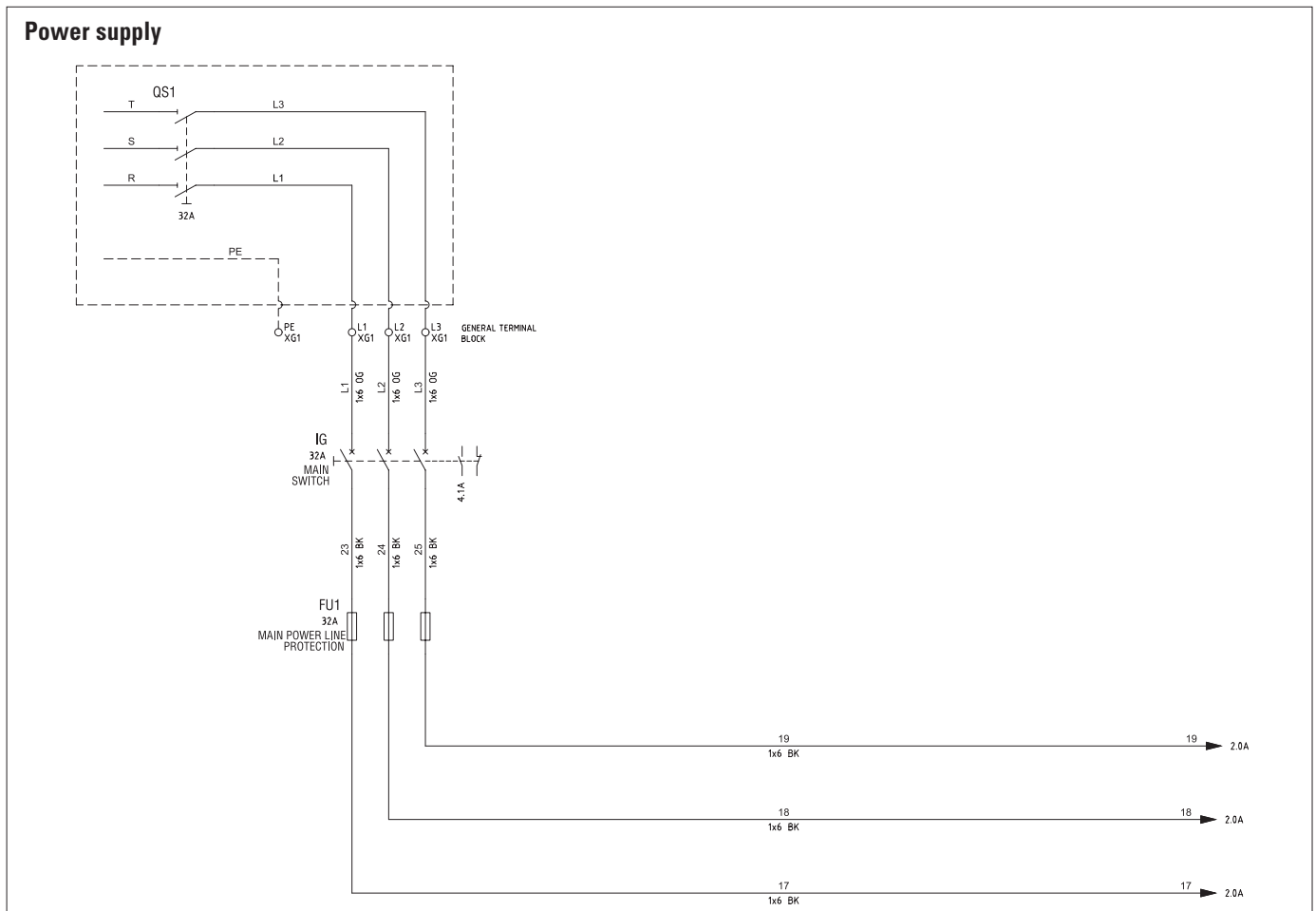

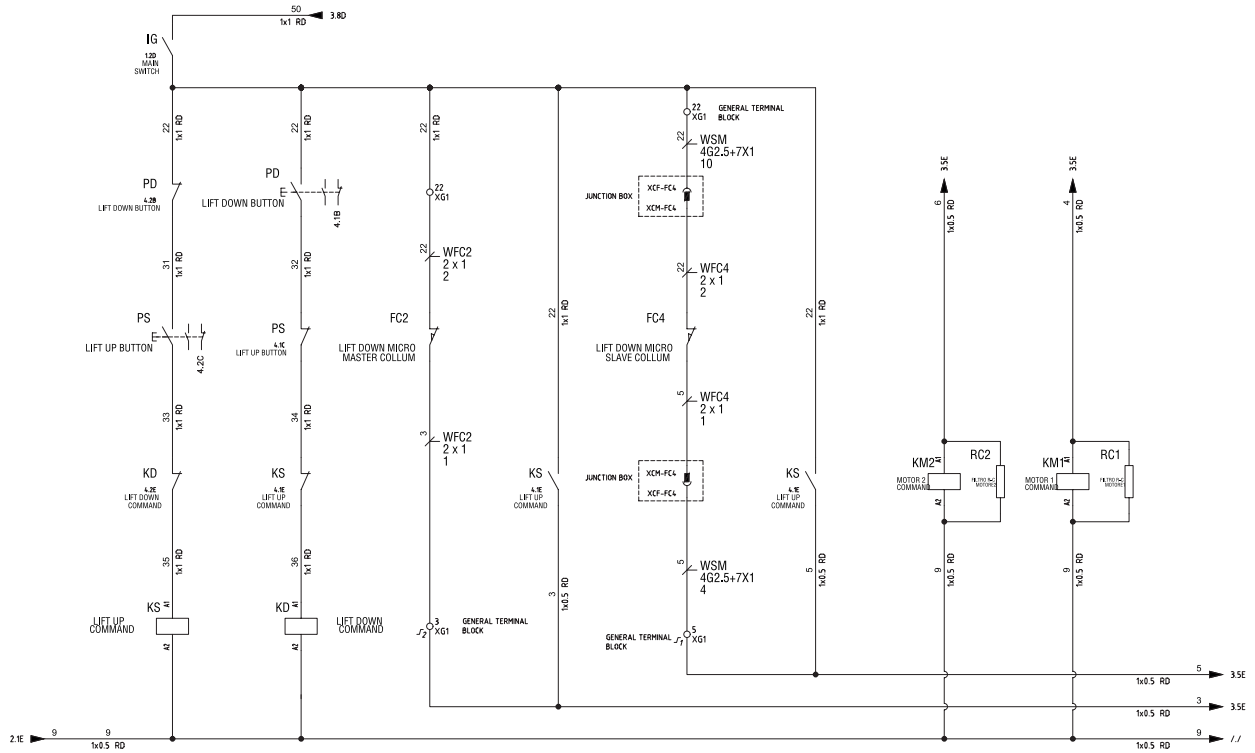
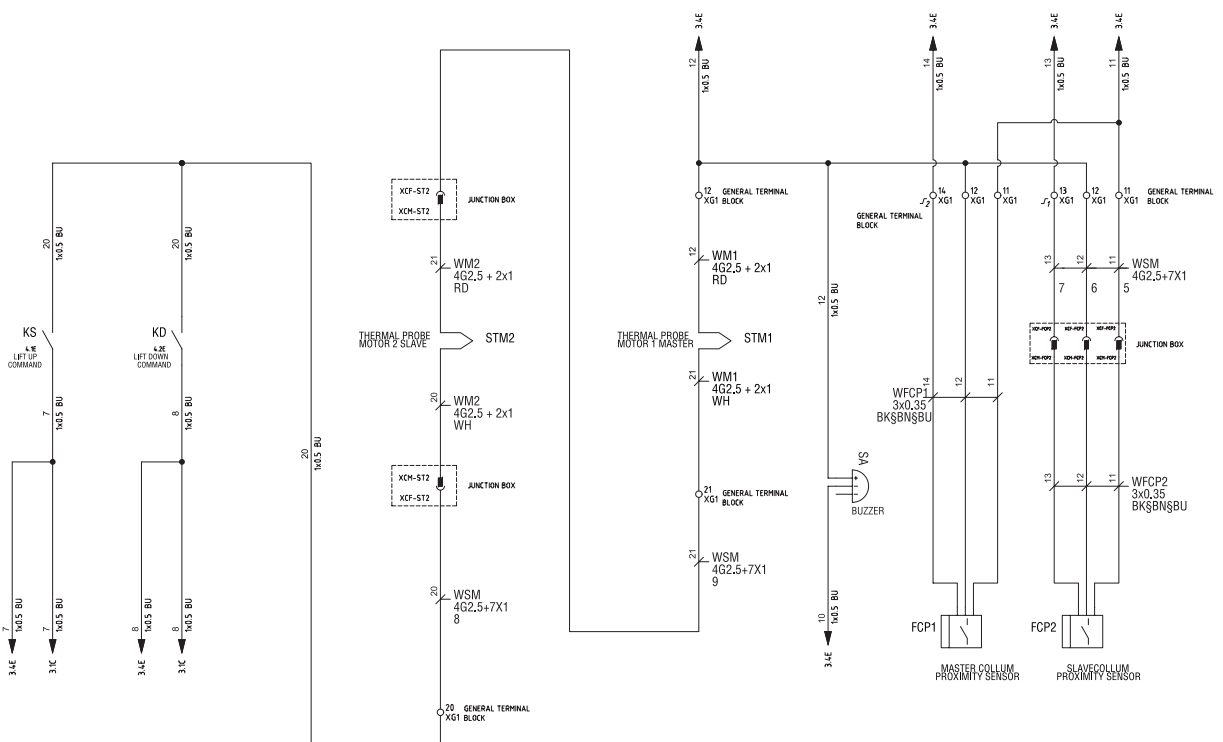
ELECTRICAL SYSTEM PART NO: 047305510
Control signals

Signals

ELECTRICAL SYSTEM PART NO: 047305510

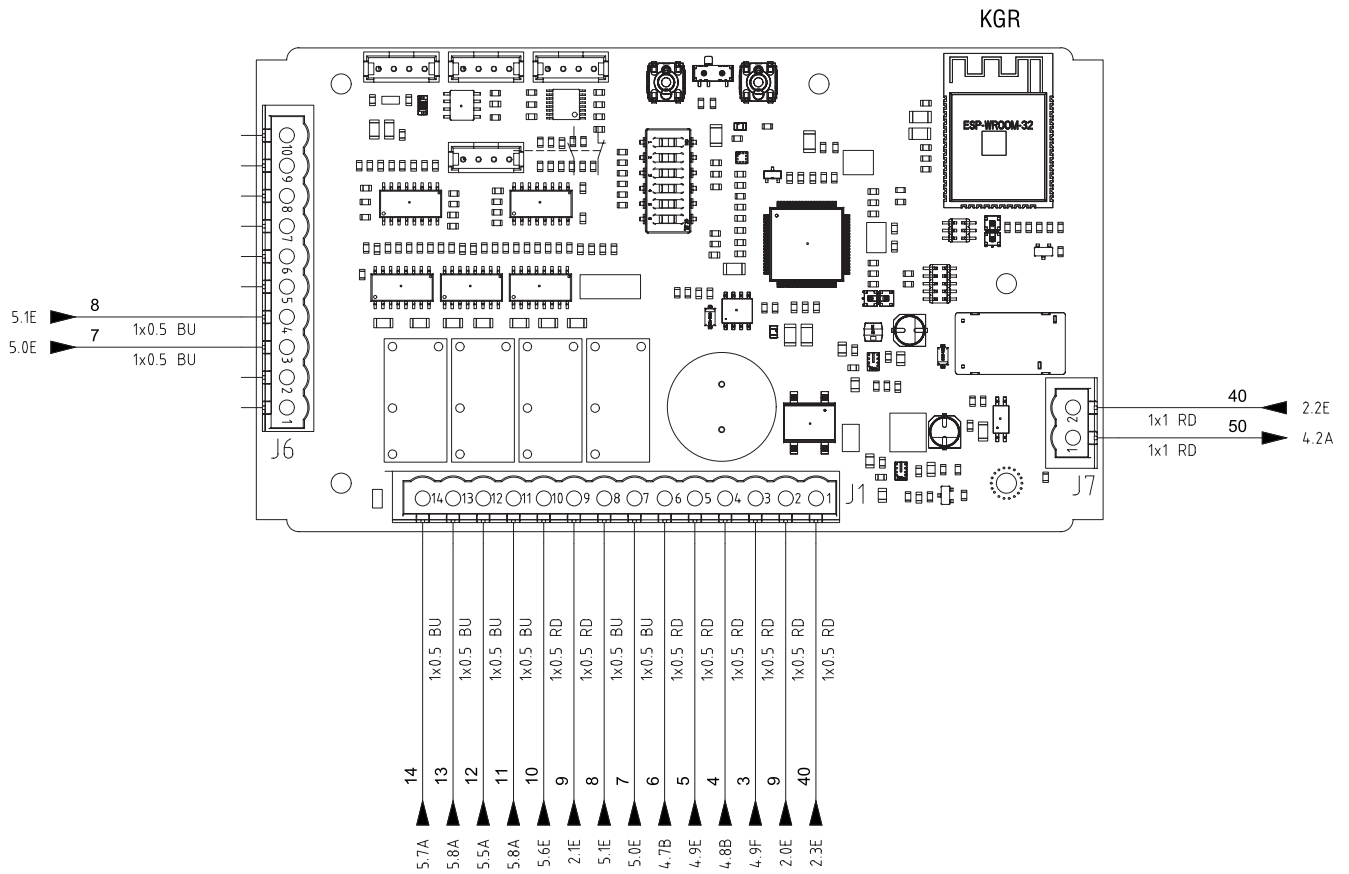
Electronic board signals



ELECTRICAL SYSTEM PART NO: 047305510
Key

LISTA CROSS REFERENCE \ CROSS REFERENCE LIST							
Componente	Reference	Dati Tecnici	Technical Data	Componente	Reference	Dati Tecnici	Technical Data
		Nome\Item:M1	Quadro\Panel: +BM Fg.\Sh:2			Nome\Item:FU3	Quadro\Panel: +QG Fg.\Sh:2
		Tipo \ Type : Costruttore \ Marke : Descrizione \ Device : Funzione \ Use Type :	Motore asincrono trifase MOTOR 1 COMMAND COLLUM			Tipo \ Type : Costruttore \ Marke : Descrizione \ Device : Funzione \ Use Type :	PORTAFUSIBILE UNIPOLARE 1A 5X20 250V 24 Vac LINE PROTECTION
		Nome\Item:M2	Quadro\Panel: +BM Fg.\Sh:2			Nome\Item:IG	Quadro\Panel: +QG Fg.\Sh:1
		Tipo \ Type : Costruttore \ Marke : Descrizione \ Device : Funzione \ Use Type :	Motore asincrono trifase MOTOR 2 SLAVE COLLUM			Tipo \ Type : Costruttore \ Marke : Descrizione \ Device : Funzione \ Use Type :	INTERRUTTORE GENERALE 4 POLI + AUX, 32A MAIN SWITCH
		Nome\Item:FC2	Quadro\Panel: +BM Fg.\Sh:4			Nome\Item:KD	Quadro\Board: +QG Fg.\Sh:4
		Tipo \ Type : Costruttore \ Marke : Descrizione \ Device : Funzione \ Use Type :	Fine corsa NC LIFT DOWN MICRO MASTER COLLUM			Tipo \ Type : Costruttore \ Marke : Descrizione \ Device : Funzione \ Use Type :	TELERUTTORE COMADO DISCESA LIFT DOWN COMMAND
		Nome\Item:FC4	Quadro\Panel: +BM Fg.\Sh:4			Nome\Item:KM1	Quadro\Panel: +QG Fg.\Sh:4
		Tipo \ Type : Costruttore \ Marke : Descrizione \ Device : Funzione \ Use Type :	Fine corsa NC LIFT DOWN MICRO SLAVE COLLUM			Tipo \ Type : Costruttore \ Marke : Descrizione \ Device : Funzione \ Use Type :	TELERUTTORE COMANDO MOTORE 1 MOTOR 1 COMMAND
		Nome\Item:FU1	Quadro\Panel: +QG Fg.\Sh:1			Nome\Item:KM2	Quadro\Panel: +QG Fg.\Sh:4
		Tipo \ Type : Costruttore \ Marke : Descrizione \ Device : Funzione \ Use Type :	PORTAFUS, TRIPOLARE 10X38 WIMEX 32A 500V MAIN POWER LINE PROTECTION			Tipo \ Type : Costruttore \ Marke : Descrizione \ Device : Funzione \ Use Type :	TELERUTTORE COMANDO MOTORE 2 MOTOR 2 COMMAND
		Nome\Item:FU2	Quadro\Panel: +QG Fg.\Sh:2			Nome\Item:KS	Quadro\Panel: +QG Fg.\Sh:4
		Tipo \ Type : Costruttore \ Marke : Descrizione \ Device : Funzione \ Use Type :	PORTAFUS, BIPOLARE 10X38 WIMEX 1A 500V TRANSFORMER POWER LINE PROTECTION			Tipo \ Type : Costruttore \ Marke : Descrizione \ Device : Funzione \ Use Type :	TELERUTTORE COMANDO SALITA LIFT UP COMMAND

LISTA CROSS REFERENCE \ CROSS REFERENCE LIST							
Componente	Reference	Dati Tecnici	Technical Data	Componente	Reference	Dati Tecnici	Technical Data
		Nome\Item:PD	Quadro\Panel: +QG Fg.\Sh:4			Nome\Item:FCP1	Quadro\Panel: +BM Fg.\Sh:5
		Tipo \ Type : Costruttore \ Marke : Descrizione \ Device : Funzione \ Use Type :	PULSANTE DISCESA LIFT DOWN BUTTON			Tipo \ Type : Costruttore \ Marke : Descrizione \ Device : Funzione \ Use Type :	INTERRUTTORE DI PROSSIMITA' PROXIMITY SENSOR
		Nome\Item:PS	Quadro\Panel: +QG Fg.\Sh:4			Nome\Item:FCP2	Quadro\Panel: +BM Fg.\Sh:5
		Tipo \ Type : Costruttore \ Marke : Descrizione \ Device : Funzione \ Use Type :	PULSANTE DISCESA LIFT UP BUTTON			Tipo \ Type : Costruttore \ Marke : Descrizione \ Device : Funzione \ Use Type :	INTERRUTTORE DI PROSSIMITA' PROXIMITY SENSOR
		Nome\Item:QS1	Quadro\Panel: +QG Fg.\Sh:1			Nome\Item:KGR	Quadro\Board: +QG Fg.\Sh:3
		Tipo \ Type : Costruttore \ Marke : Descrizione \ Device : Funzione \ Use Type :	INTERRUTTORE GENERALE CLIENTE 32A CLIENT POWER MAIN SWITCH			Tipo \ Type : Costruttore \ Marke : Descrizione \ Device : Funzione \ Use Type :	SCHEDA ELETTRONICA ELECTRONIC BOARD
		Nome\Item:RC1	Quadro\Panel: +QG Fg.\Sh:4			Nome\Item:STM1	Quadro\Panel: +BM Fg.\Sh:5
		Tipo \ Type : Costruttore \ Marke : Descrizione \ Device : Funzione \ Use Type :	FILTRO ANTIDISTURBI R-C MOTORE1			Tipo \ Type : Costruttore \ Marke : Descrizione \ Device : Funzione \ Use Type :	SONDA TERMICA THERMAL PROBE MOTOR 1 MASTER
		Nome\Item:RC2	Quadro\Panel: +QG Fg.\Sh:4			Nome\Item:STM2	Quadro\Panel: +BM Fg.\Sh:5
		Tipo \ Type : Costruttore \ Marke : Descrizione \ Device : Funzione \ Use Type :	FILTRO ANTIDISTURBI R-C MOTORE2			Tipo \ Type : Costruttore \ Marke : Descrizione \ Device : Funzione \ Use Type :	SONDA TERMICA THERMAL PROBE MOTOR 2 SLAVE
		Nome\Item:SA	Quadro\Panel: +QG Fg.\Sh:5			Nome\Item:TRS	Quadro\Panel: +QG Fg.\Sh:2
		Tipo \ Type : Costruttore \ Marke : Descrizione \ Device : Funzione \ Use Type :	AVVISATORE ACUSTICO BUZZER			Tipo \ Type : Costruttore \ Marke : Descrizione \ Device : Funzione \ Use Type :	TRASFORMATORE 100 V/A TRANSFORMER 400V - 24VAC

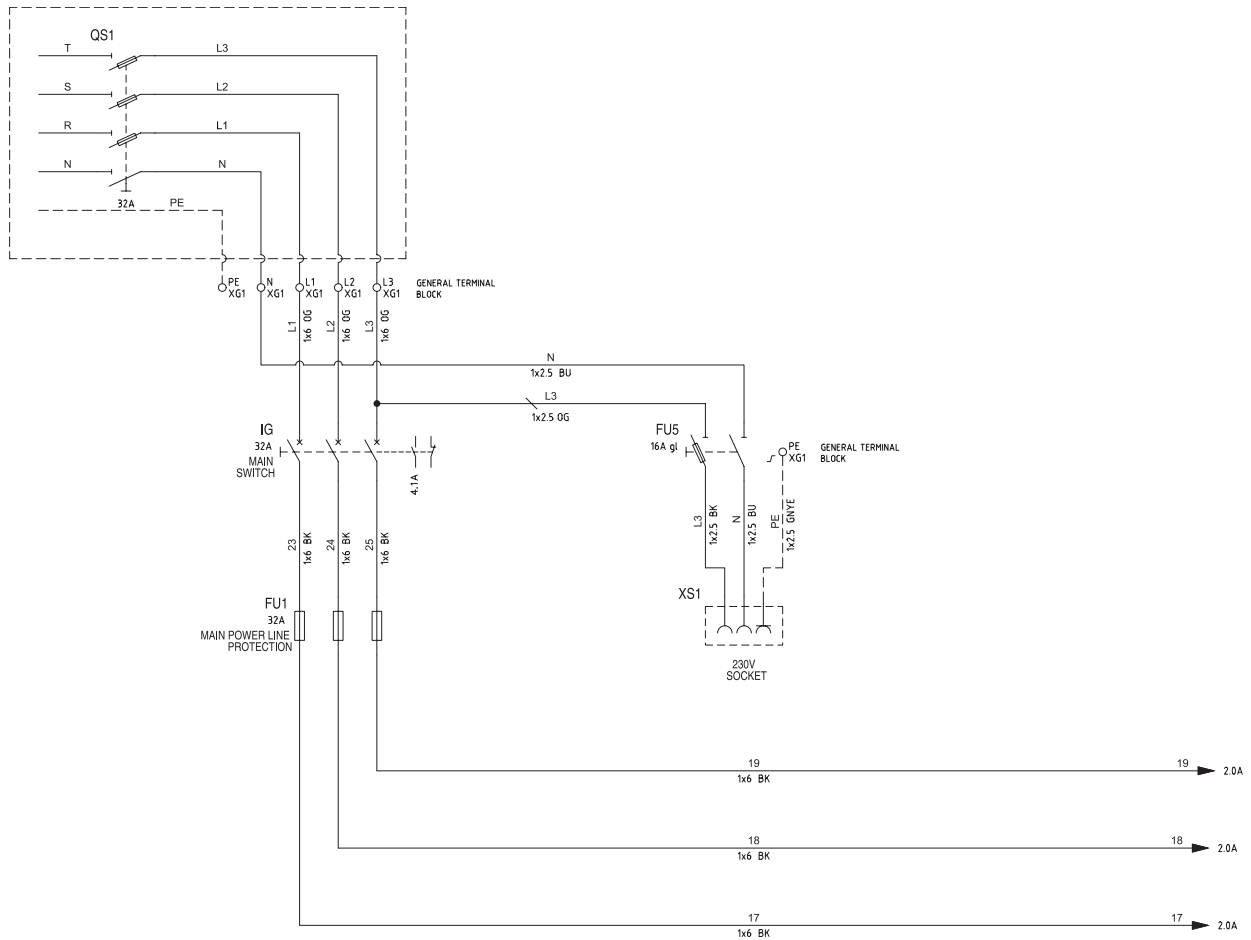
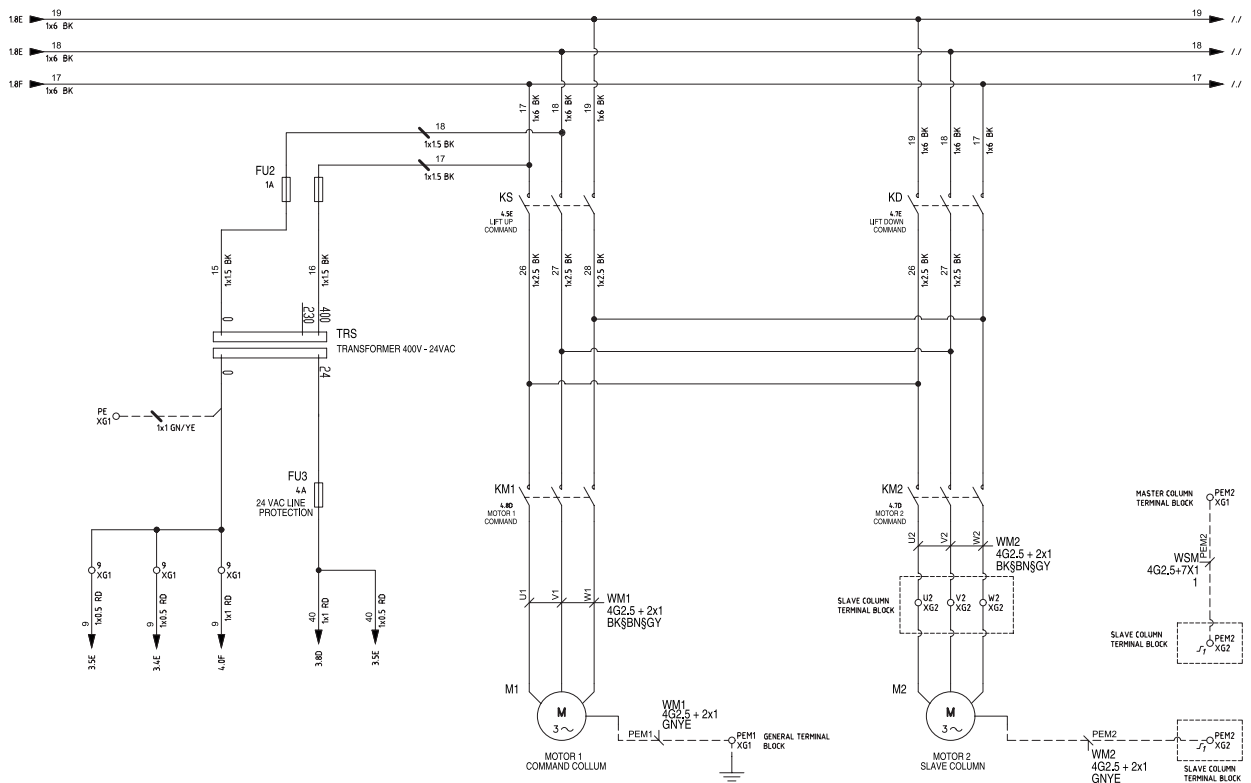
ELECTRICAL SYSTEM PART NO: 047305530
Power supply

Motor power supply

ELECTRICAL SYSTEM PART NO: 047305530

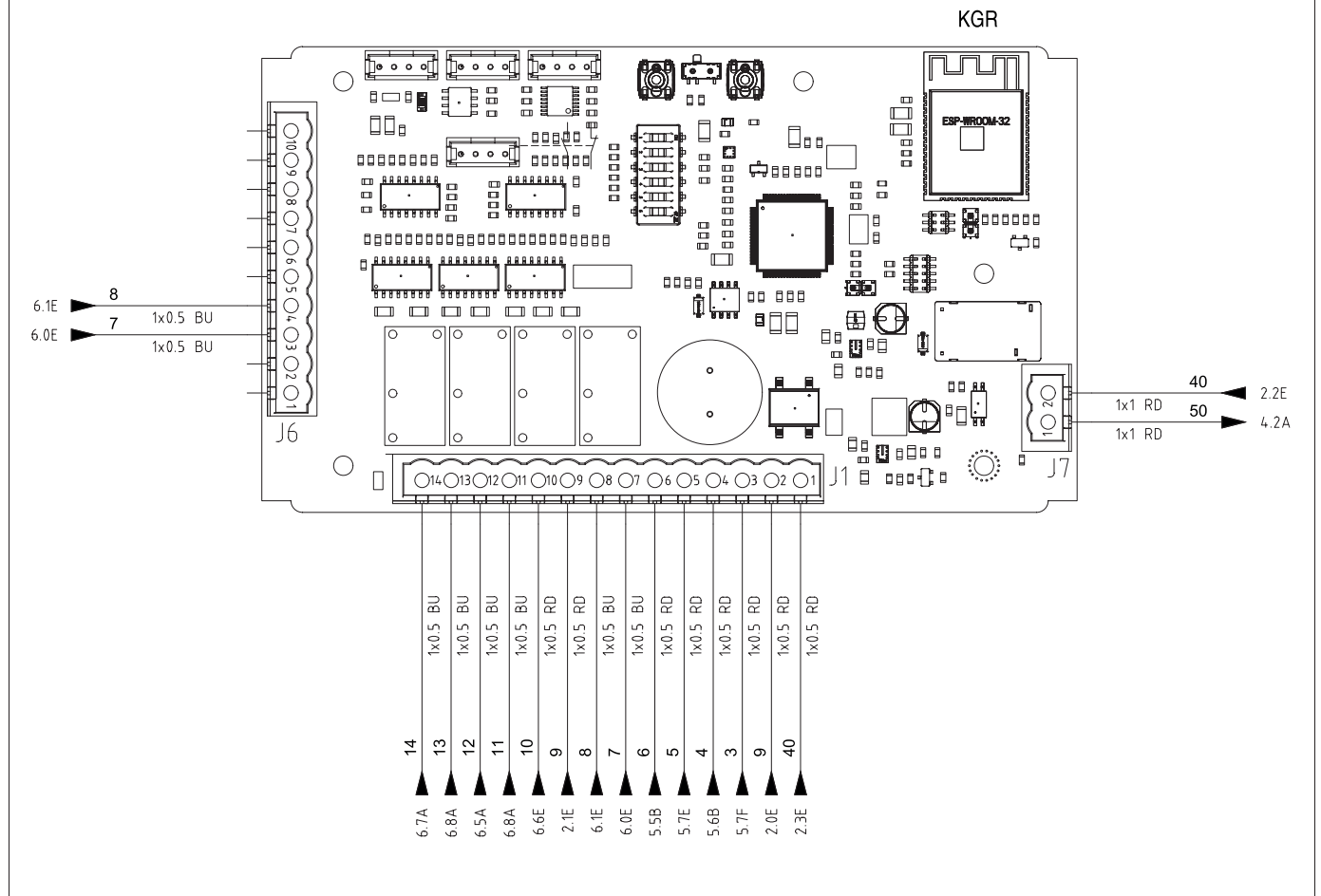
Electronic board signals

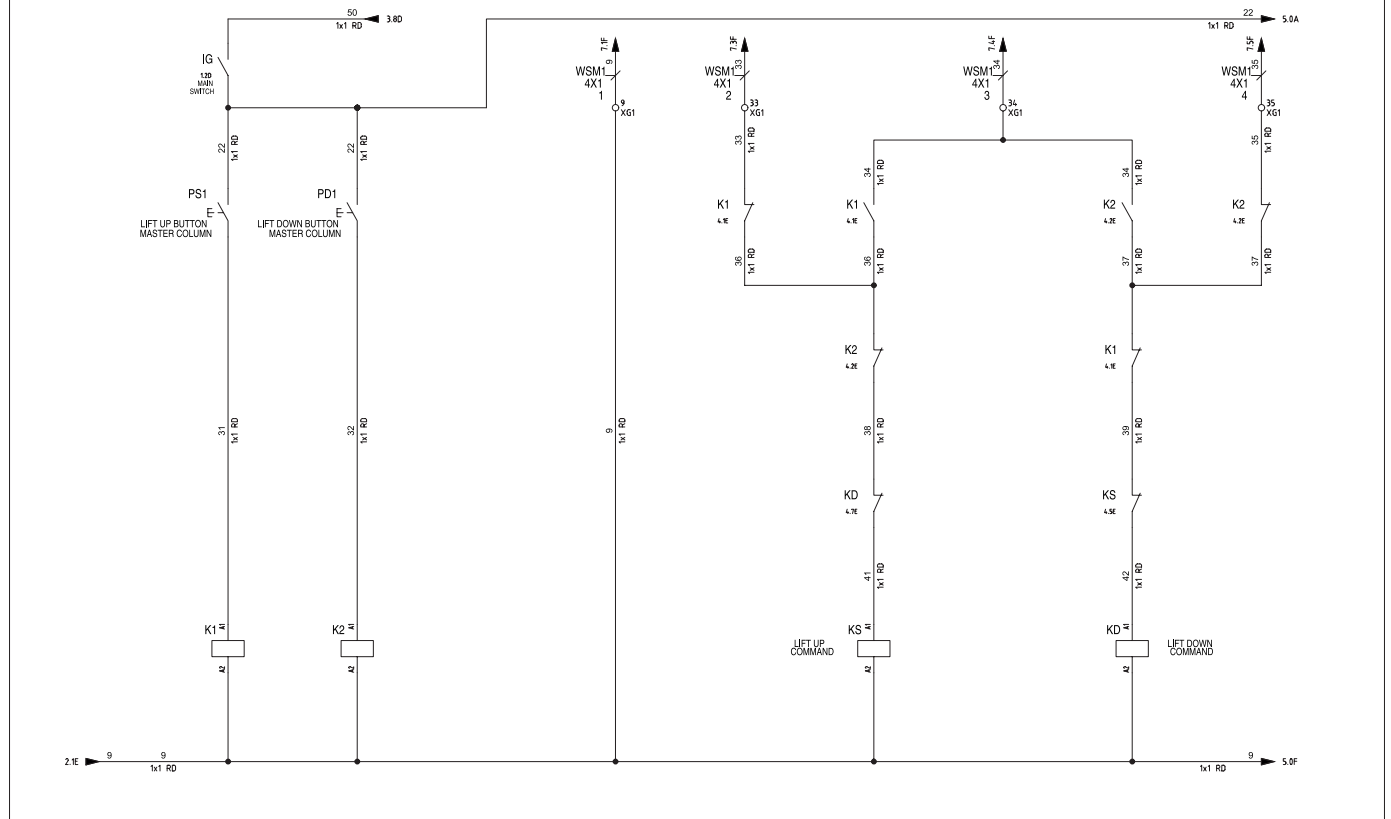

Control signals



ELECTRICAL SYSTEM PART NO: 047305530

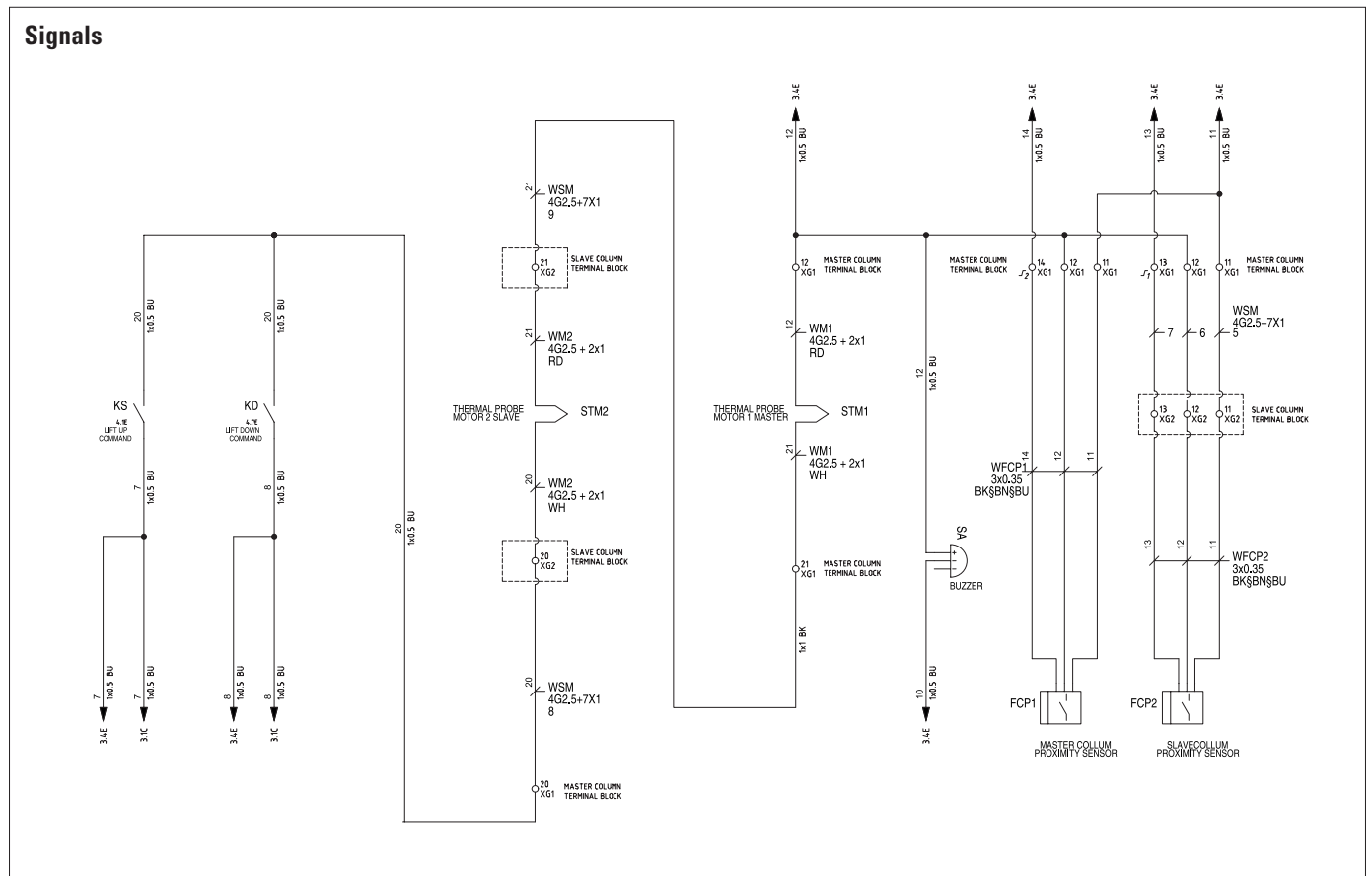
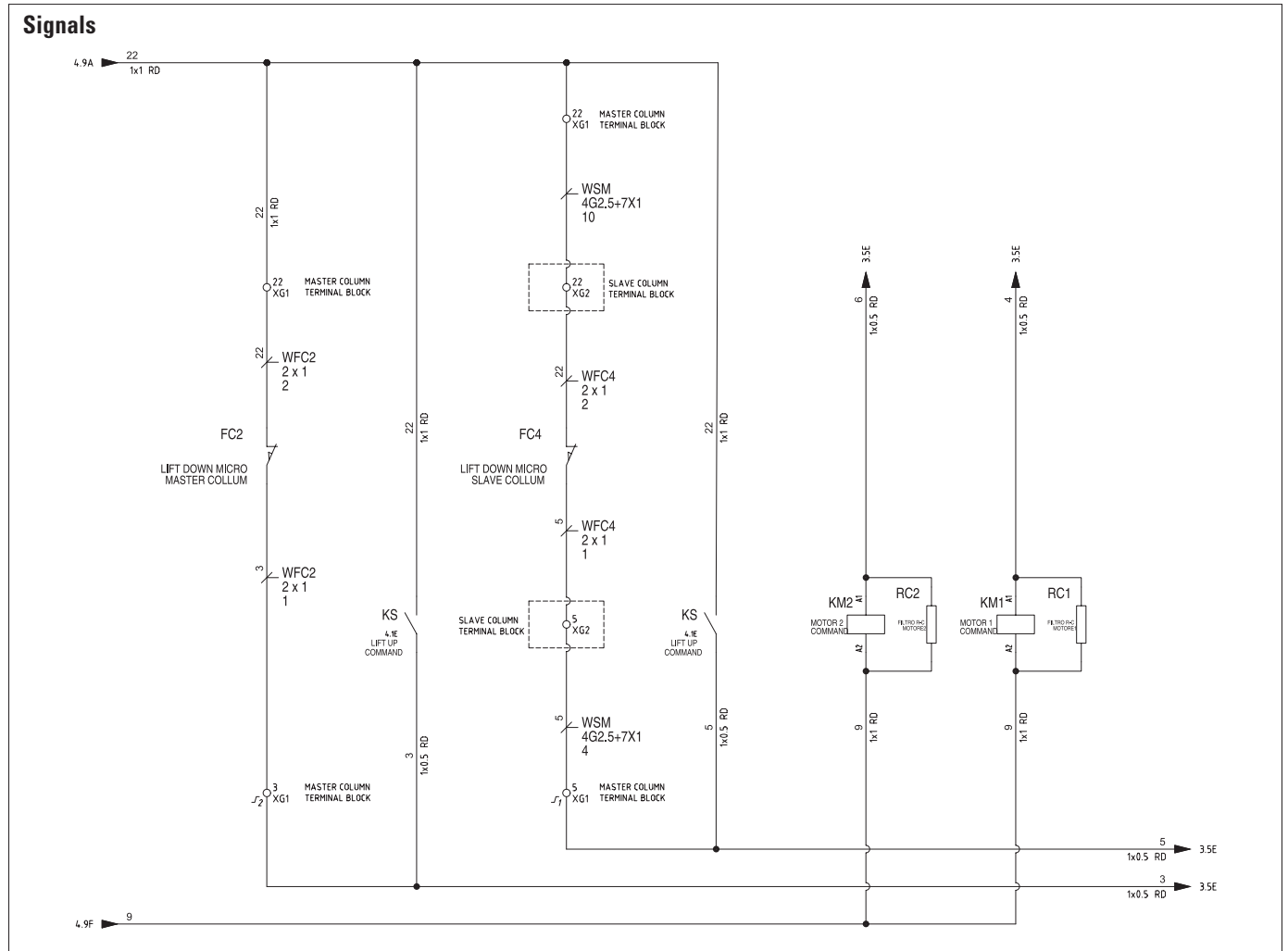

ELECTRICAL SYSTEM PART NO: 047305530
Key

LISTA CROSS REFERENCE \ CROSS REFERENCE LIST							
Componente	Reference	Dati Tecnici	Technical Data	Componente	Reference	Dati Tecnici	Technical Data
		Nome\Item:M1	Quadro\Panel: +BM Fg.\Sh.:2			Nome\Item:FU3	Quadro\Panel: +QG Fg.\Sh.:2
		Tipo \ Type : Costruttore \ Marke: Descrizione \ Device : Motore asincrono trifase Funzione \ Use Type : MOTOR 1 COMMAND COLLUM				Tipo \ Type : Costruttore \ Marke: Descrizione \ Device : PORTAFUSIBILE UNIPOLARE 1A 5X20 250V Funzione \ Use Type : 24 VaC LINE PROTECTION	
		Nome\Item:M2	Quadro\Panel: +BM Fg.\Sh.:2			Nome\Item:IG	Quadro\Panel: +QG Fg.\Sh.:1
		Tipo \ Type : Costruttore \ Marke: Descrizione \ Device : Motore asincrono trifase Funzione \ Use Type : SLAVE COLUMN				Tipo \ Type : Costruttore \ Marke: Descrizione \ Device : INTERRUTTORE GENERALE 4 POLI + AUX. 32A Funzione \ Use Type : MAIN SWITCH	
		Nome\Item:FC2	Quadro\Panel: +BM Fg.\Sh.:4			Nome\Item:KD	Quadro\Board: +QG Fg.\Sh.:4
		Tipo \ Type : Costruttore \ Marke: Descrizione \ Device : Fine corsa NC Funzione \ Use Type : LIFT DOWN MICRO MASTER COLLUM				Tipo \ Type : Costruttore \ Marke: Descrizione \ Device : TELERUTTORE COMADO DISCESA Funzione \ Use Type : LIFT DOWN COMMAND	
		Nome\Item:FC4	Quadro\Panel: +BM Fg.\Sh.:4			Nome\Item:KM1	Quadro\Panel: +QG Fg.\Sh.:4
		Tipo \ Type : Costruttore \ Marke: Descrizione \ Device : Fine corsa NC Funzione \ Use Type : LIFT DOWN MICRO SLAVE COLLUM				Tipo \ Type : Costruttore \ Marke: Descrizione \ Device : TELERUTTORE COMANDO MOTORE 1 Funzione \ Use Type : MOTOR 1 COMMAND	
		Nome\Item:FU1	Quadro\Panel: +QG Fg.\Sh.:1			Nome\Item:KM2	Quadro\Panel: +QG Fg.\Sh.:4
		Tipo \ Type : Costruttore \ Marke: Descrizione \ Device : PORTAFUS. TRIPOLARE 10X38 WIMEX 32A 500V Funzione \ Use Type : MAIN POWER LINE PROTECTION				Tipo \ Type : Costruttore \ Marke: Descrizione \ Device : TELERUTTORE COMANDO MOTORE 2 Funzione \ Use Type : MOTOR 2 COMMAND	
		Nome\Item:FU2	Quadro\Panel: +QG Fg.\Sh.:2			Nome\Item:KS	Quadro\Panel: +QG Fg.\Sh.:4
		Tipo \ Type : Costruttore \ Marke: Descrizione \ Device : PORTAFUS. BIPOLARE 10X38 WIMEX 1A 500V Funzione \ Use Type : TRANSFORMER POWER LINE PROTECTION				Tipo \ Type : Costruttore \ Marke: Descrizione \ Device : TELERUTTORE COMANDO SALITA Funzione \ Use Type : LIFT UP COMMAND	

LISTA CROSS REFERENCE \ CROSS REFERENCE LIST							
Componente	Reference	Dati Tecnici	Technical Data	Componente	Reference	Dati Tecnici	Technical Data
		Nome\Item:PD	Quadro\Panel: +QG Fg.\Sh.:4			Nome\Item:FCP1	Quadro\Panel: +BM Fg.\Sh.:5
		Tipo \ Type : Costruttore \ Marke: Descrizione \ Device : PULSANTE DISCESA Funzione \ Use Type : LIFT DOWN BUTTON				Tipo \ Type : Costruttore \ Marke: Descrizione \ Device : INTERRUTTORE DI PROSSIMITA' Funzione \ Use Type : PROXIMITY SENSOR	
		Nome\Item:PS	Quadro\Panel: +QG Fg.\Sh.:4			Nome\Item:FCP2	Quadro\Panel: +BM Fg.\Sh.:5
		Tipo \ Type : Costruttore \ Marke: Descrizione \ Device : PULSANTE DISCESA Funzione \ Use Type : LIFT UP BUTTON				Tipo \ Type : Costruttore \ Marke: Descrizione \ Device : INTERRUTTORE DI PROSSIMITA' Funzione \ Use Type : PROXIMITY SENSOR	
		Nome\Item:QS1	Quadro\Panel: +QG Fg.\Sh.:1			Nome\Item:KGR	Quadro\Board: +QG Fg.\Sh.:3
		Tipo \ Type : Costruttore \ Marke: Descrizione \ Device : INTERRUTTORE GENERALE CLIENTE 32A Funzione \ Use Type : CLIENT POWER MAIN SWITCH				Tipo \ Type : Costruttore \ Marke: Descrizione \ Device : SCHEDA ELETTRONICA Funzione \ Use Type : ELECTRONIC BOARD	
		Nome\Item:RC1	Quadro\Panel: +QG Fg.\Sh.:4			Nome\Item:STM1	Quadro\Panel: +BM Fg.\Sh.:5
		Tipo \ Type : Costruttore \ Marke: Descrizione \ Device : FILTRO ANTIDISTURBI R-C Funzione \ Use Type : MOTORE1				Tipo \ Type : Costruttore \ Marke: Descrizione \ Device : SONDA TERMICA Funzione \ Use Type : THERMAL PROBE MOTOR 1 MASTER	
		Nome\Item:RC2	Quadro\Panel: +QG Fg.\Sh.:4			Nome\Item:STM2	Quadro\Panel: +BM Fg.\Sh.:5
		Tipo \ Type : Costruttore \ Marke: Descrizione \ Device : FILTRO ANTIDISTURBI R-C Funzione \ Use Type : MOTORE2				Tipo \ Type : Costruttore \ Marke: Descrizione \ Device : SONDA TERMICA Funzione \ Use Type : THERMAL PROBE MOTOR 2 SLAVE	
		Nome\Item:SA	Quadro\Panel: +QG Fg.\Sh.:5			Nome\Item:TRS	Quadro\Panel: +QG Fg.\Sh.:2
		Tipo \ Type : Costruttore \ Marke: Descrizione \ Device : AVVISATORE ACUSTICO Funzione \ Use Type : BUZZER				Tipo \ Type : Costruttore \ Marke: Descrizione \ Device : TRASFORMATORE 100 V/A Funzione \ Use Type : TRANSFORMER 400V - 24VAC	
		Nome\Item: FU5	Quadro\Panel: +QG Fg.\Sh.:1			Nome\Item:	Quadro\Panel: Fg.\Sh.:
		Tipo \ Type : Costruttore \ Marke: Descrizione \ Device : Funzione \ Use Type :PROTEZIONE LINA 230V PRESA				Tipo \ Type : Costruttore \ Marke: Descrizione \ Device : Funzione \ Use Type :	
		Nome\Item: XS1	Quadro\Panel: +QG Fg.\Sh.:1			Nome\Item:	Quadro\Panel: Fg.\Sh.:
		Tipo \ Type : Costruttore \ Marke: Descrizione \ Device : PRESA 230V Funzione \ Use Type :				Tipo \ Type : Costruttore \ Marke: Descrizione \ Device : Funzione \ Use Type :	

CH. 4 GENERAL SAFETY PRECAUTIONS



4.1 INDICATION OF OUTSTANDING RISKS

Our lift has been manufactured according to the most stringent standards required by applicable directives. Risk analysis has been carefully made and all hazards have, as far as possible, been eliminated. Any outstanding risks are evidenced in this manual and on the machine by pictograms.

4.2 SAFETY PLATES AND/OR STICKERS

There are plates and stickers on the lift to identify the machine, its capacity, instructions and electrical system. In the event of these pictograms being damaged, they must be replaced by new ones available from ROTARY.

4.3 STAFF TRAINING

The equipment may only be operated by specially trained and authorised staff.

To ensure that the machine is used in the best possible way and that work can be carried out efficiently, the staff responsible for the machine must be properly trained to handle the necessary information in order to achieve an operative method in line with the instructions supplied by the manufacturer.

For any doubts concerning use and maintenance of the machine, refer to the instructions manual and, if necessary, authorised technical service centres or the ROTARY technical service department.

4.4 SUITABILITY FOR USE

This product has been manufactured in compliance with the European Directive 2006/42/CE. According to article 4.1.2.3 (Annex 1) of this Directive, the coefficients used for the tests are as follows:

1.10 for the Dynamic test

1.25 for the Static test

These tests must be performed by specialised personnel.

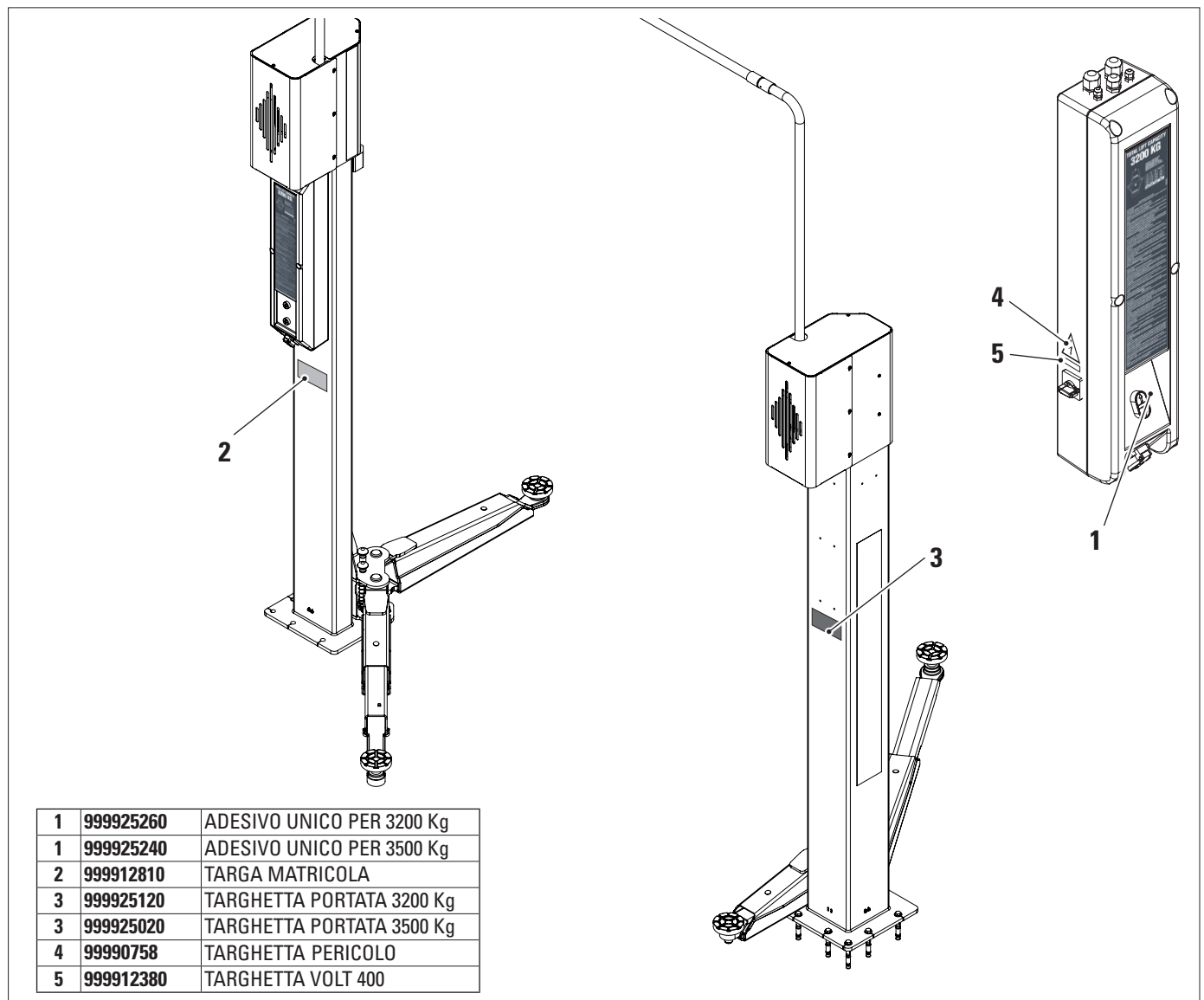

CH. 5 INSTALLATION REQUIREMENTS

5.1 MINIMUM REQUIREMENTS FOR THE PLACE OF INSTALLATION

Make sure that the place where the machine is to be installed complies with the following requirements:

- the use of the lift is allowed only inside enclosed areas, where there is no danger of explosion or fire.
- the lift is not suitable for use where vehicle washing is involved.
- sufficient lighting (nonetheless the place must not be subject to glare or intense light). UNI 10380 reference standard;
- place not exposed to the weather;
- place with adequate air exchange;
- pollutant-free environment;
- noise level below the regulatory requirements in force at I 70 dB (A);
- room temperature: min. 5° - max 55°;
- the workplace must not be exposed to dangerous movements due to other machines in operation;
- the room where the machine is installed must not be used to store explosive, corrosive and/or toxic materials;
- the distance of the columns from walls or any fixed equipment must be at least 50 cm.
- choose the installation layout considering that from the control position the operator must be able to view the entire machine and the surrounding area. S/he must prevent the presence of unauthorised persons and objects that could cause a source of danger in this area.

All installation procedures related to external power supply connections (in particular electrical) must be performed by qualified personnel.

Installation must be carried out by authorised personnel following the special instructions described in this manual; if in doubt, please refer to authorised service centres or ROTARY technical service.

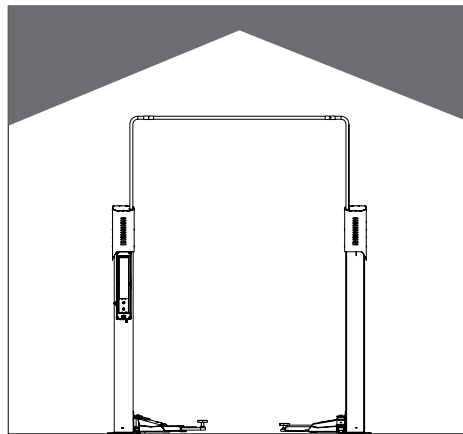

YES

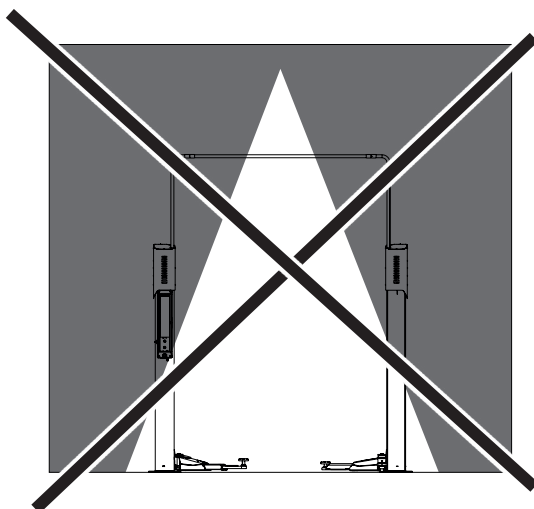

NO

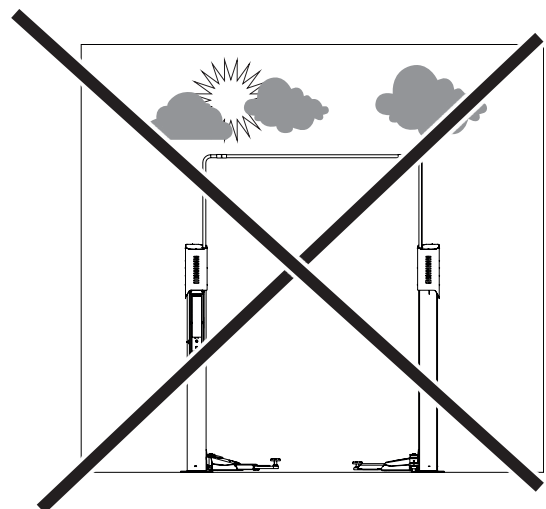

NO

5.2 FLOORING REQUIREMENTS

The lift must be installed on a flat, horizontal floor capable of bearing the LOADS TRANSMITTED TO THE SUPPORTING FLOOR shown in the table (fig. B). The minimum requirements are:

- a) Concrete quality: C25/30 min
- b) Floor minimum thickness: 160mm (net of any floor and related screeds) (*)

It is advised to consult a qualified technician for installation suitability

(*) Minimum thickness depends on the block type used

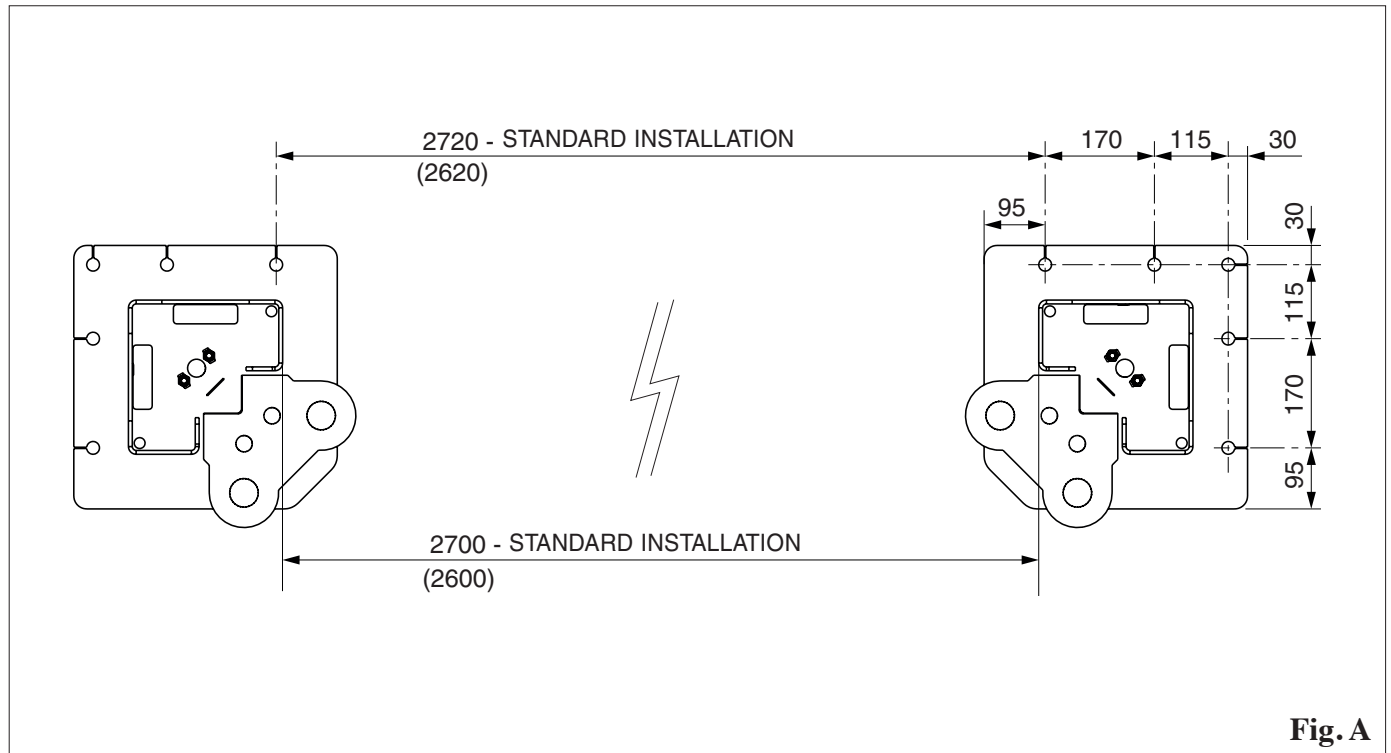
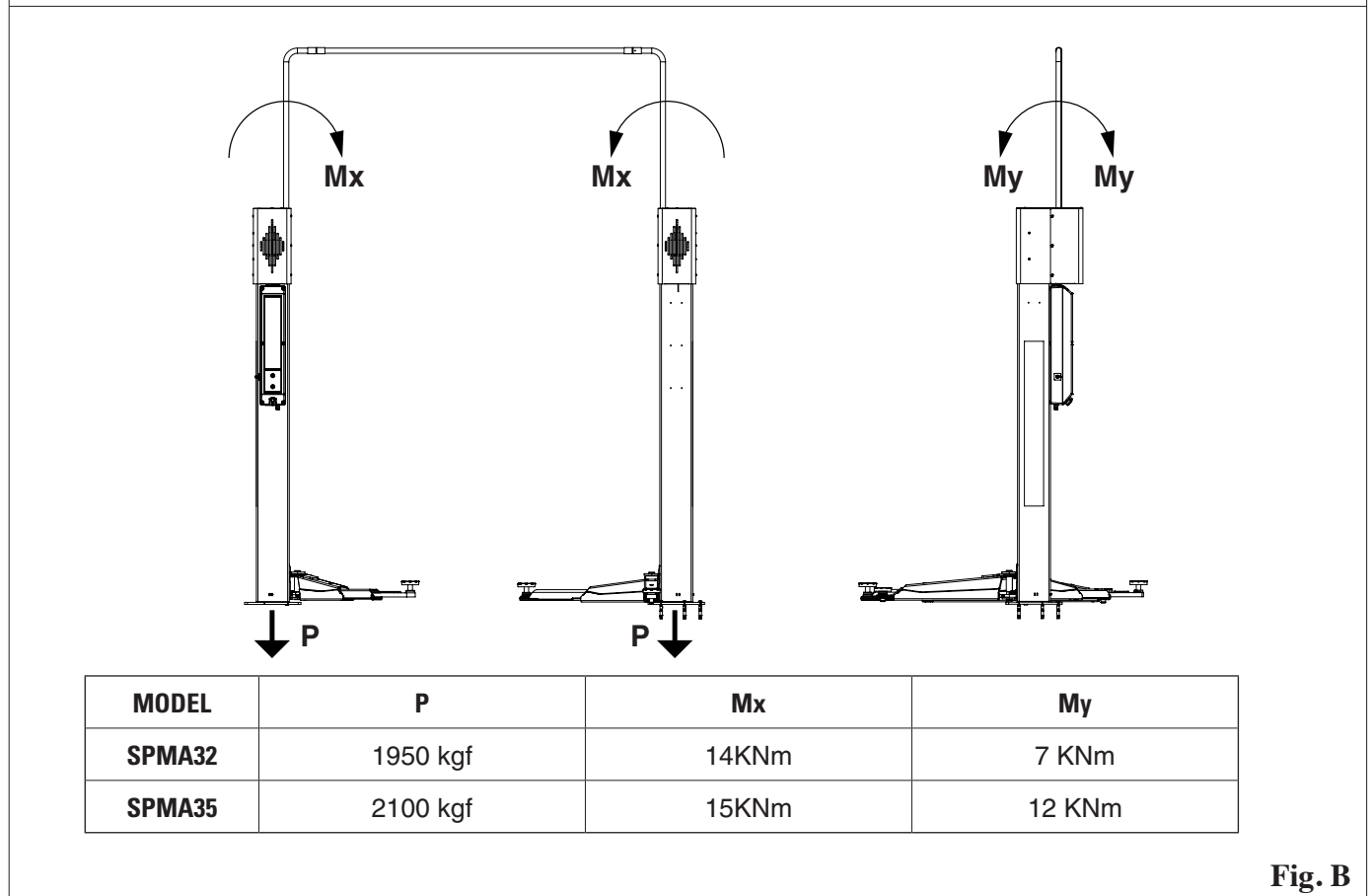
Fig. A

Fig. B

CH. 6 PRE-INSTALLATION AND MOVEMENT

- The lift is dispatched as shown in the illustration (fig. A).
- Package (1) contains the accessories and the small parts for assembly completion.
- Lifting must be done as shown in the illustration. (fig. B).
- Raise with care and move the various units to the unpacking site.

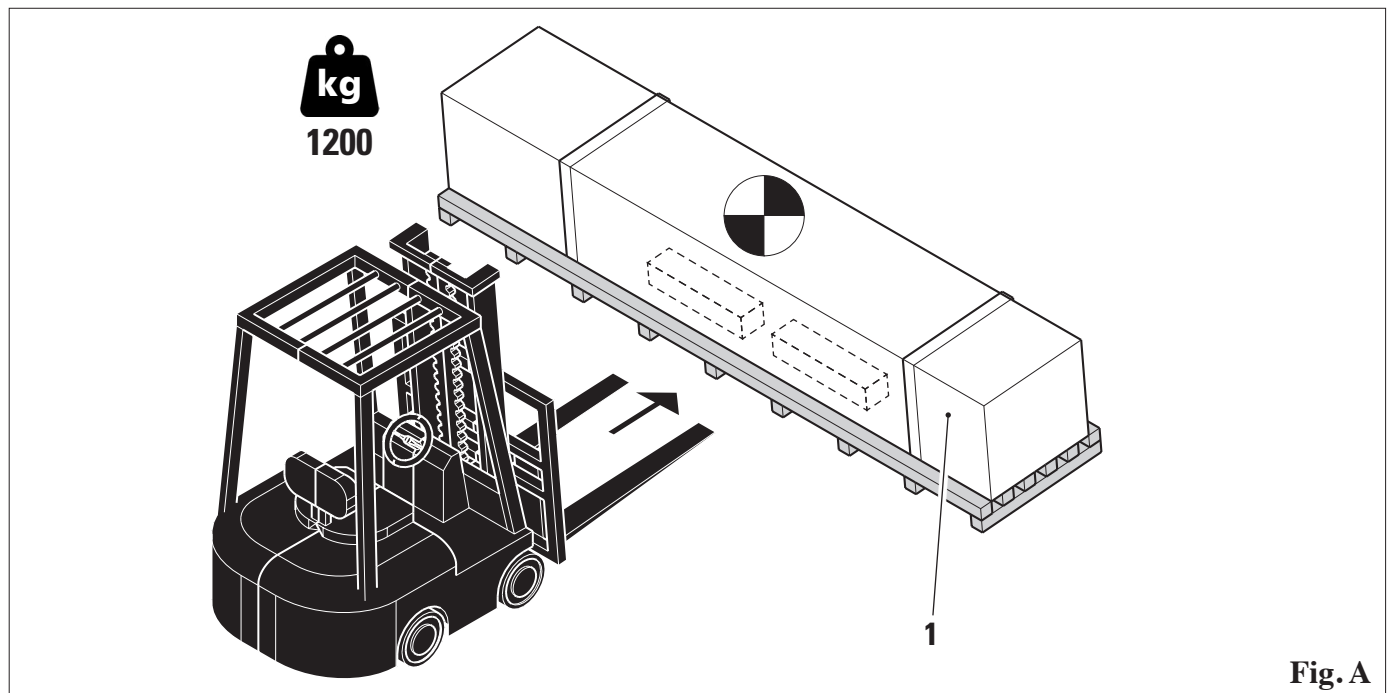
- Proceed as follows when moving the machine to the chosen installation point (or for subsequent re-positioning):
- lift with care, using suitable means of load support which are in perfect working order and using the special hooking points as shown in the illustration (fig. B).
- avoid sudden jolts and pulling, watch out for uneven surfaces, bumps etc..
- take special care with outjutting parts: obstacles, difficult throughways, etc..
- wear suitable clothing and protective gear.
- after removing the various packaging materials, check that these are taken to special waste collecting areas inaccessible to children and animals where they will subsequently be disposed of.
- on receiving the goods, check that the packaging has not been opened. Once unpacked, check that nothing has been damaged.

Fig. A

Handling procedure:
 Fit in the eye bolt (2) (optional) on the screw (3).
 Position the strap (4) in the eye bolt and on the load support as shown in the figure.
 Carefully lift the column until it is upright.
 Remove the strap from the eye bolt.
 Remove the eye bolt (2).

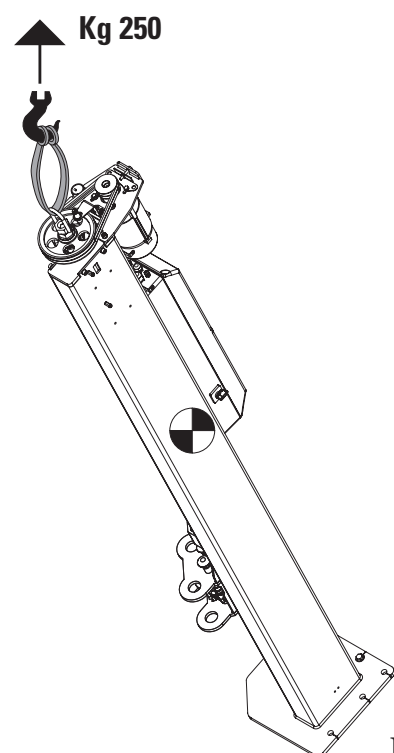
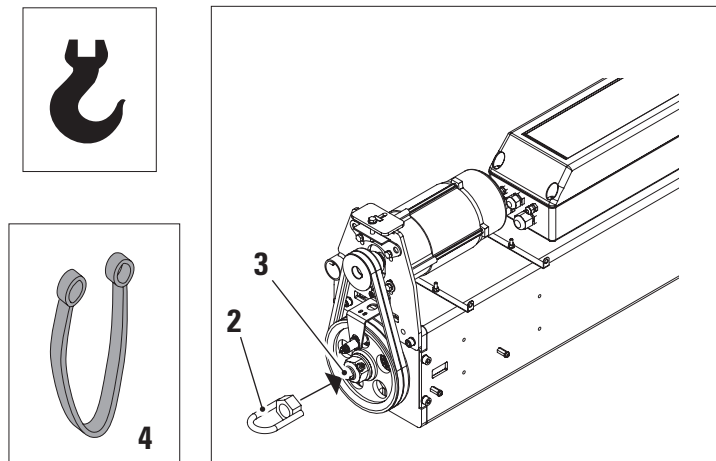
Fig. B

CH. 7 INSTALLATION

7.1 BLOCKS

The lift must be secured to the floor by means of mechanical expansion blocks (HILTI HSL-3 M12 or similar) or by means of chemical anchors in vials (HILTI HVU-M12 or similar) (with M12 threaded bar made of steel class 5.8 or higher).

As regards the depth of the concrete in relation to the floor level, **THE BLOCKS MUST BE LONG ENOUGH TO GET TO THE BEARING FLOOR.** (see fig. **A-B**).

7.2 CONCRETE

For lower class concrete we recommend the use of suitable chemical anchors.

NOTE It is recommended that the base of the columns be placed directly on the concrete, even if there is a raised floor. However, if this is of good quality it is possible to secure the columns directly on the floor by using anchors long enough.

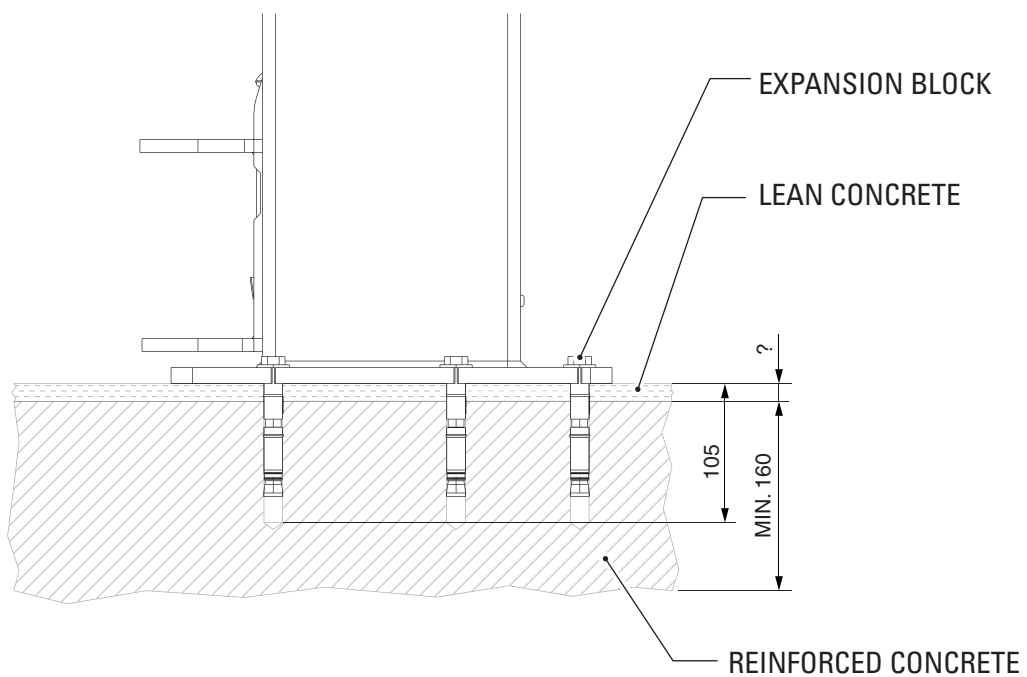
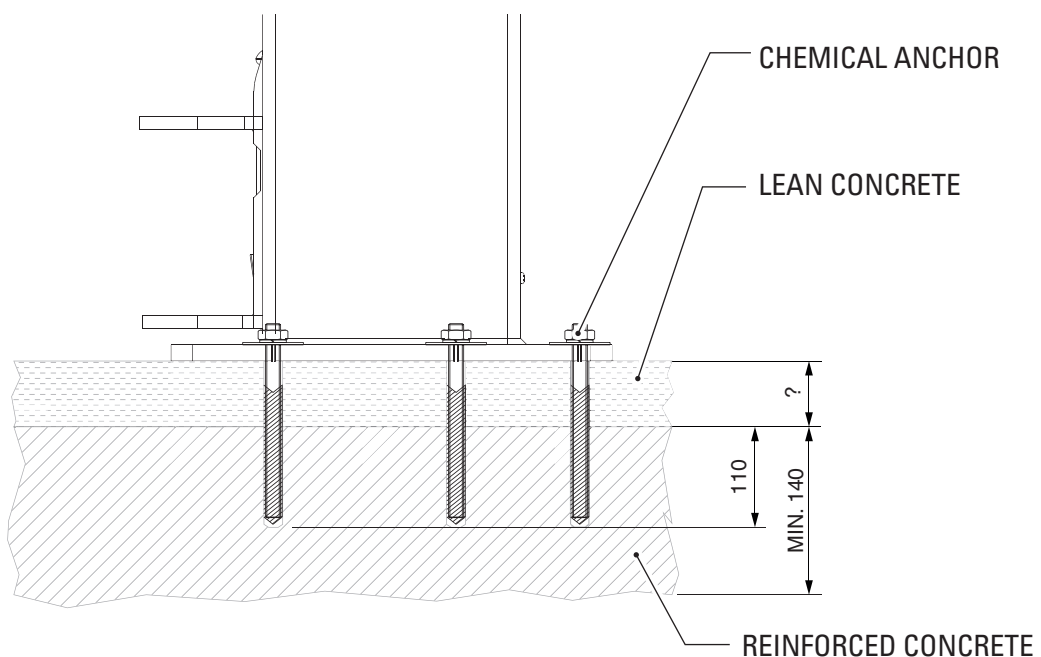
Fig. A

Fig. B



7.3 INSTALLATION INSTRUCTIONS



The anchor bolts must be fitted using the base plates as drilling templates

NOTE: Please refer to the technical specifications provided by the block manufacturer for the block positioning and application methods. Installation procedure:

- position a column vertically;
- Provide spacers to close any gap under the base plate (fig. B)
- mark out the holes and drill them following the procedures indicated by the block manufacturer;
- fix the block in position;
- bring the other column upright and position it at the distance indicated in **ch. 5.2**;
- proceed with the drilling and block fixing steps described above for both columns.

  Check the anchoring after about ten fully-loaded runs, checking the tightening torque of the bolts. This inspection must be made every 3 months.

- Fit in the cable gland tube (1) on the motor support plates.
- Route the electric cable (2) inside the tube (1).
- Make the connections to the junction box (fig. C).

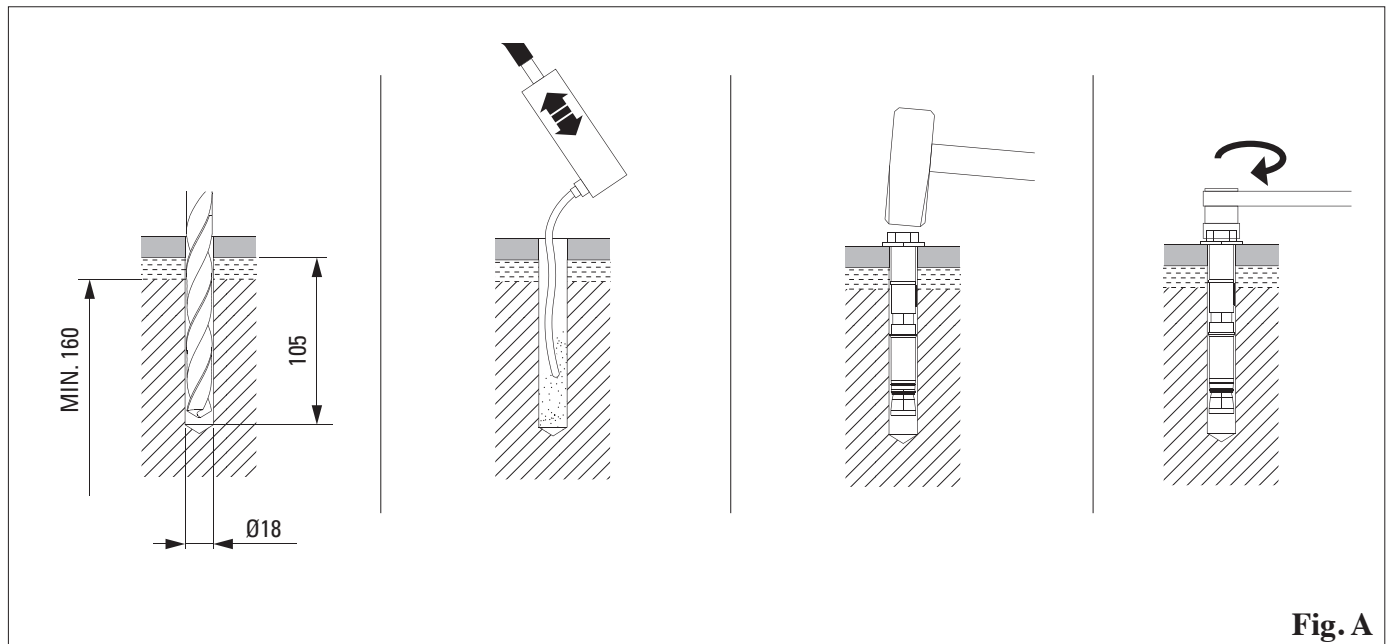

Fig. A

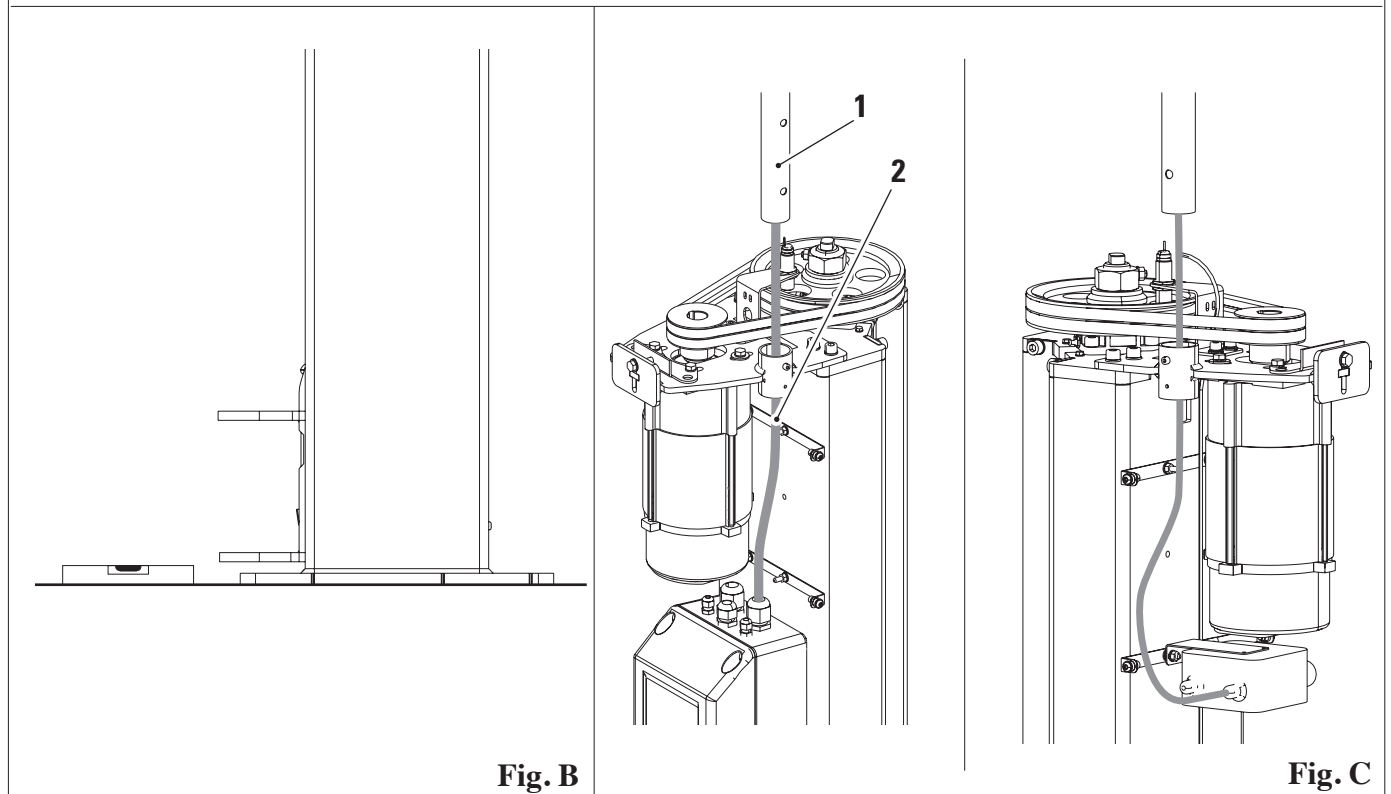

Fig. B

Fig. C

7.4 VOLTAGE CHECK

Check that the voltage of the system corresponds to the mains voltage. If not so, make the appropriate changes to the electric system and change the voltage of the motor.

7.5 CONNECTING UP TO THE MAINS

Versione trifase: 400V 50Hz 380V 60Hz

sezione cavo $\geq 4\text{mm}^2$ 3poli + terra P=11KW I=20A

Versione trifase: 230V 50Hz 220V 60Hz

sezione cavo $\geq 6\text{mm}^2$ 3poli + terra P=11KW I=32A

Controllare inoltre che a monte si trovi un dispositivo di interruzione automatica contro le sovracorrenti dotato di salvavita da 30mA.

7.6 CONNECTIONS

- Pass the power cable inside the box through the cable grip and connect the wires to the terminal board (see wiring diagram).

First Installation.

Warning: Lift platforms could be misaligned due to packing.

Take platforms to ground (downstroke limit) as described in chapt. 8.5 of the manual.

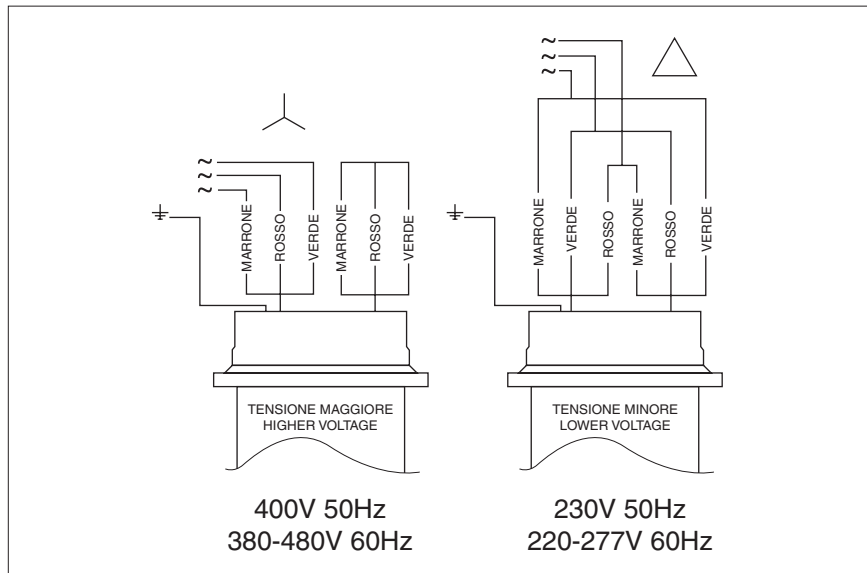
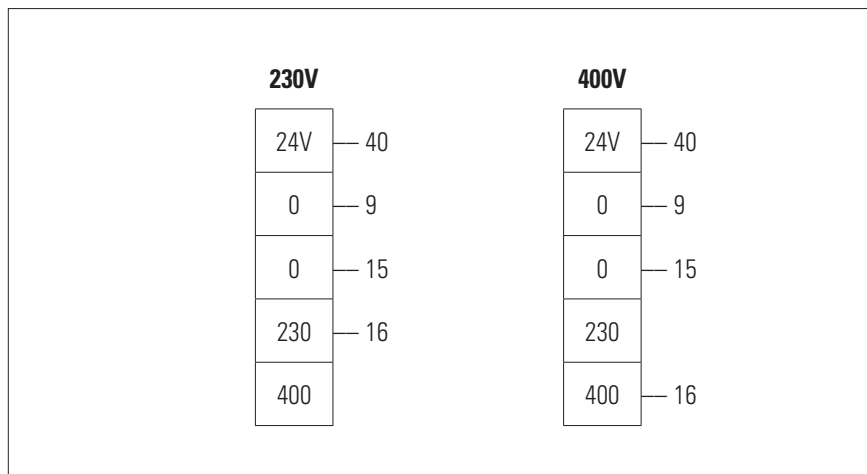

Any work done on electrical parts, including minor jobs, must be carried out by specialised engineers.

MOTOR CONNECTION

CONNECTING THE TRANSFORMER

FUSES

230V	400V
32A	20A

The electrical system is preset to work at the voltage shown on the serial number plate.

7.7 COMPLETION AND CHECK

- Operate the down run control, manually setting the lower limit switch. Downward movement should stop.
- Operate the up run control until the carriages are fully raised and make sure the upper limit switch engages to stop these.
- Fill the post tanks with ESSO GEAR OIL GX 85W – 140 up to indicated level (refer to ch. 10).
- Fit in the pulley sensor plate on both columns Fig. **A**. Check that there is a gap of 0.5 mm between the sensor and the pulley (Fig. **B**).

- Fit in the covers as shown in Fig. **C**:
 - Fit in the cover (1) by fixing it to the supports (2);
 - Fit in the cover (3) by fixing it to the cover (1) and to the supports (4)
 - Fit in the cover (5) by fixing it to the covers (1) and (3).

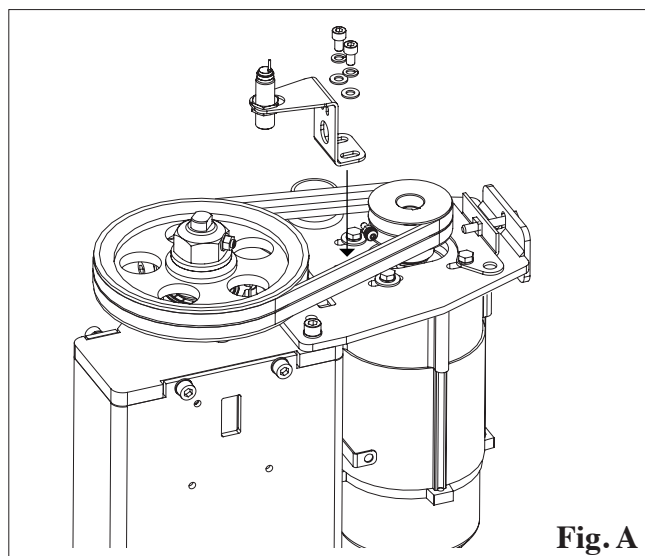
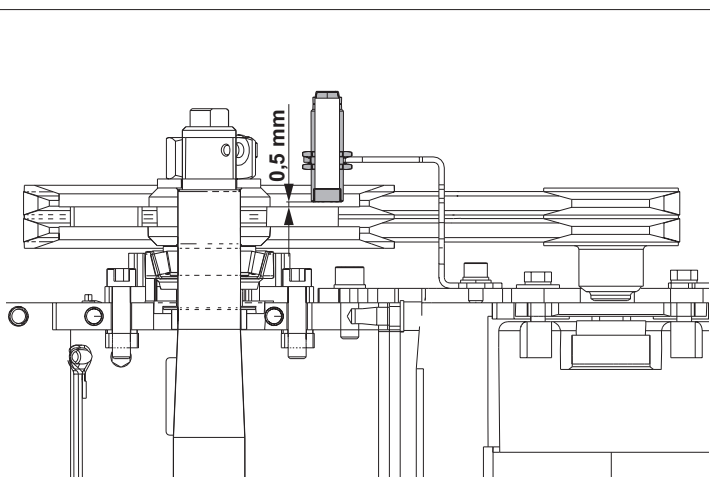
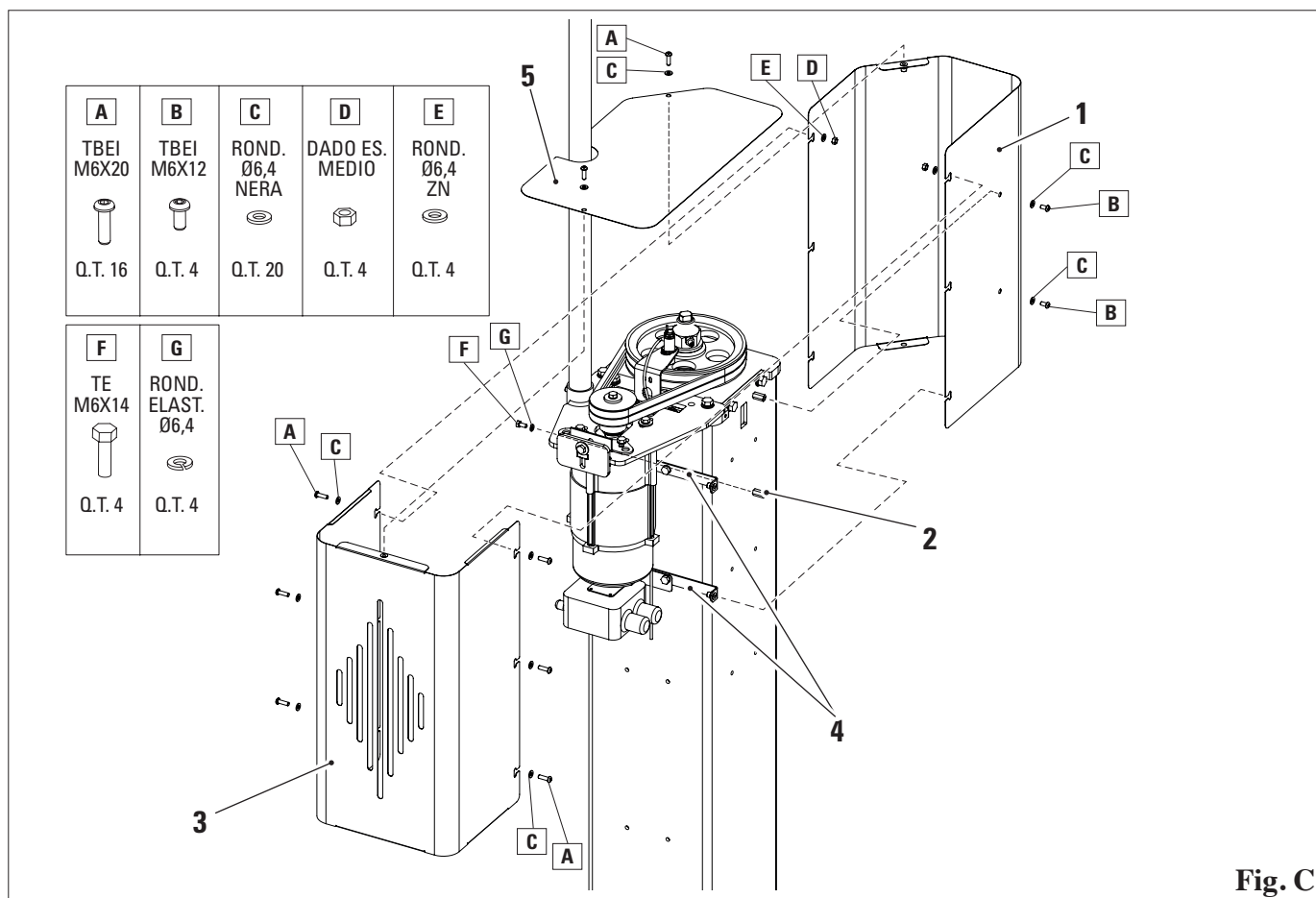

The identification plate must be always clearly visible after installation.

Fig. A

Fig. B

Fig. C

7.8 ARM FITTING



- Move the carriages to a height of 70-80 cm
- Fit in the long and short arms:

disassemble the toothed wheel (1) by unscrewing the respective screws; remove the pin (2); insert the arm inside the carriage wings and reassemble the pin (2) and toothed wheel (1), securing it with the screws.

7.9 USE OF ACCESSORIES

The lift may be used with accessories to facilitate the operator's work.

  *Only original manufacturer's accessories may be used.*

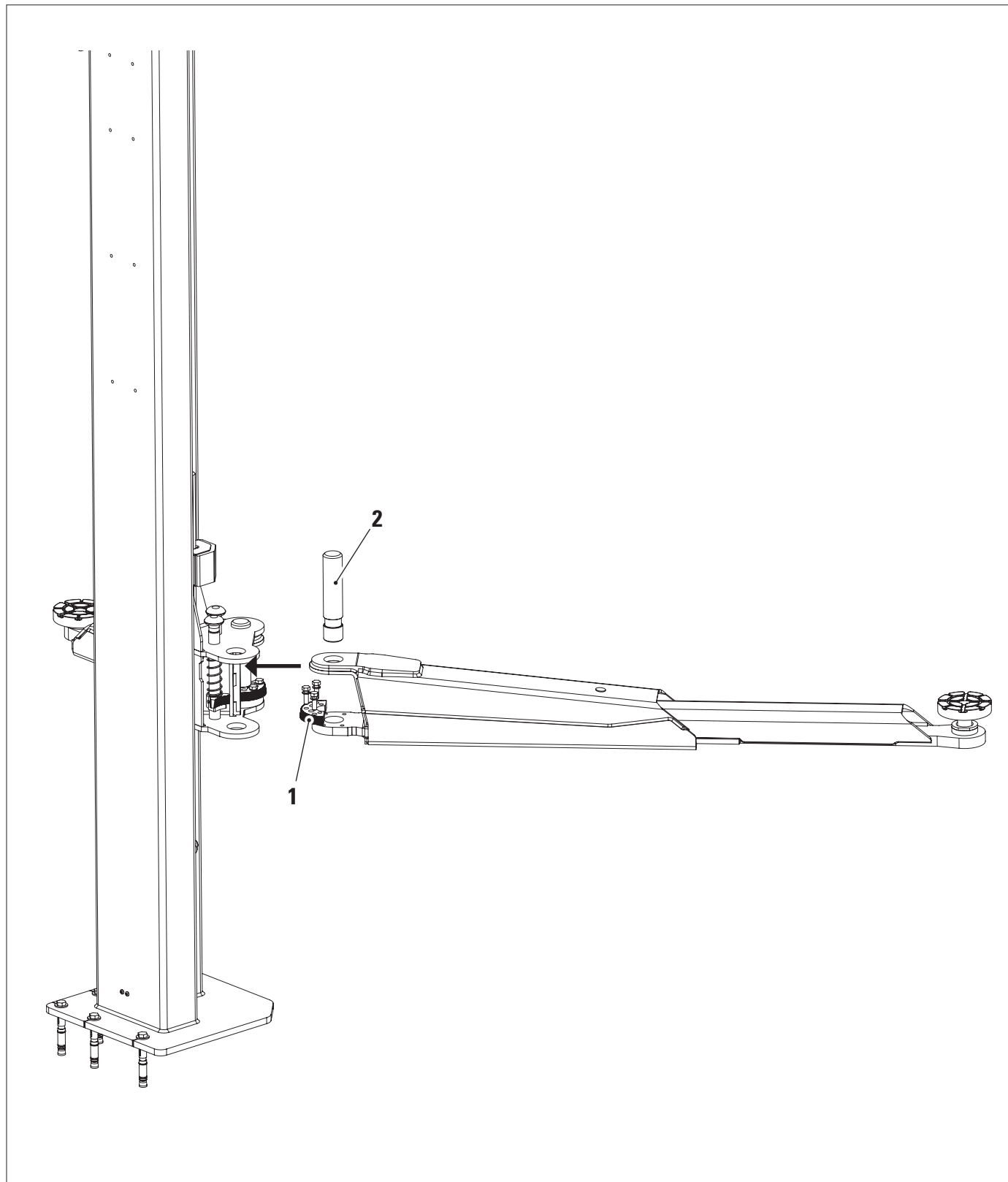

CH. 8 USING THE LIFT



8.1 IMPORTANT CHECKS TO BE MADE



It is absolutely forbidden to stay underneath the vehicle during lifting and lowering operations!

- Check that dangerous situations do not occur while work is being carried out. Stop the machine immediately if any operation problems are noticed and contact the authorised dealer's technical service.
- Check that the work area around the machine is free from potentially dangerous objects and that oil (or other greasy liquid) has not been spilt on the floor, causing potential danger to the operator.
- The operator must wear suitable work clothing, safety goggles, gloves and mask to avoid damage caused by dust or impurities, dangling objects such as bracelets or such like must not be worn, long hair must be tied back, shoes must be suitable for the work to be done.
- Check that dismantling of part of the vehicle does not alter the load distribution beyond pre-set acceptable limits.
- Turn the mains switch to zero when work is done on the lifted vehicle.

8.2 HANDLING AND BEHAVIOUR DURING LIFT OPERATION

Follow the procedures described below:

- Identify the weight of the vehicle.
 - Identify the load distribution.
 - Make sure to centre the vehicle in relation to the lift as accurately as possible.
 - Identify the vehicle pick-up points and follow the manufacturer's instructions.
- **Procedure for correct pad positioning:** use your hands to hold and extend the telescopic arm (see figure); direct the pad and position it on the previously identified vehicle pick-up points. Do not use feet or other systems other than those listed.
- Raise the carriage to a height of slightly more than 30cm and with pressure on the vehicle check the correct stability of the pick-up points and the coupling of the stops.
 - During the lifting and lowering movement, check the support point on the vehicle.

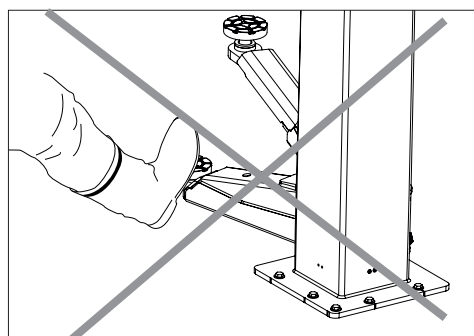
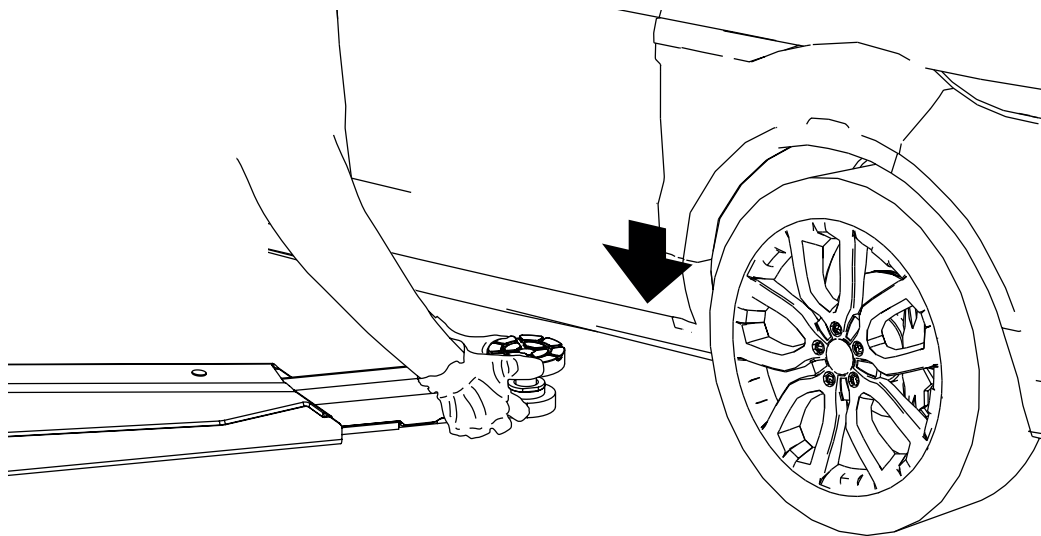

8.3 DESCRIPTION AND FUNCTION OF CONTROLS



Control box part no. **047303060 - 047303070 / 047303080**

Control identification: SWITCH (1), PUSH-BUTTON (2), PUSH-BUTTON (3) ACOUSTIC WARNING (4), EMERGENCY BUTTON (5)

Function:

	<ul style="list-style-type: none"> • Electric circuit deactivated • Lockable position 		<p>Pressed: upward movement</p>
	<ul style="list-style-type: none"> • Electric circuit activated • TEqLINK activated 		<p>Pressed: downward movement</p>
	<ul style="list-style-type: none"> • Push-buttons (2) and (3) deactivated • TEqLINK activated • Lockable position 		<p>Pressed: it deactivates the electric circuit</p>
			<p>Active: lift blocked and carriage at dangerous height with downward control activated</p>

047303060

Control box with switch and up/down push-buttons.

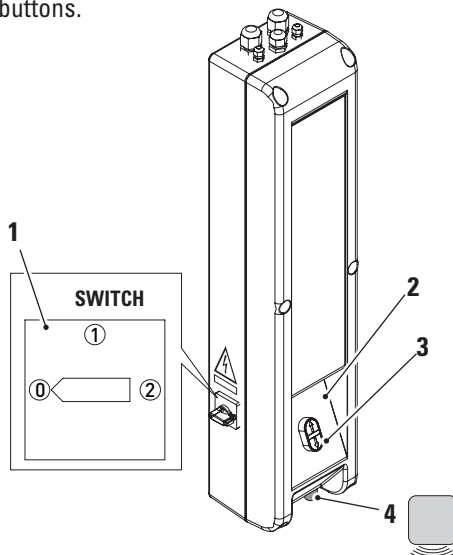

047303070 / 047303080

Double control box with switch, up and down push-buttons, emergency button.

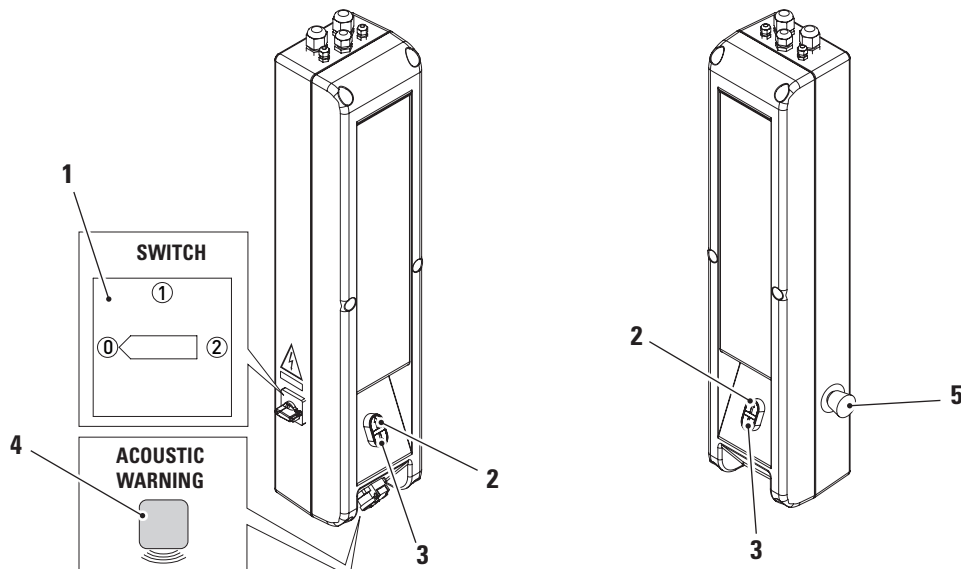

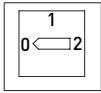
EMERGENCY PROCEDURE: EMERGENCY DROP WITH POWER OFF

Turn the switch to the 0 position (remove the possibility of power supply return).

- **EMERGENCY LOWERING:** In the event of a power failure, it is possible to bring the load back to the ground by removing the covers at the top of the columns and turning the actuator screws with a mm17 spanner, alternately the control column and the opposite column so as not to exceed 50 mm difference between the carriage heights.

Once the electric circuit has been restored, the contactors must be reset by making the lift move up 5 cm and then down.



WARNING! Have this operation carried out by qualified personnel, taking special care to the load position so as to avoid any unbalance between the two platforms that could affect load stability.

8.4 IMPROPER USE OF THE LIFT

The lift is intended for lifting vehicles with the characteristics specified in ch. 2. and ch. 3.

Any other use is to be considered unsuitable and unreasonable. In particular, the following situations are absolutely prohibited:

- 1) lifting people or animals
- 2) lifting vehicles with people inside
- 3) lifting vehicles containing potentially dangerous materials, (explosives, corrosives, inflammable substances, etc..)
- 4) lifting vehicles NOT positioned on the pickup points
- 5) lifting vehicles with accessories not envisaged by ROTARY
- 6) use of the lift by staff who are not adequately trained and authorised.
- 7) Use it as a jack.
- 8) Use a single pair of arms longitudinally or transversely.
- 9) Use a single arm.
- 10) Use the arms for compressing and crushing.

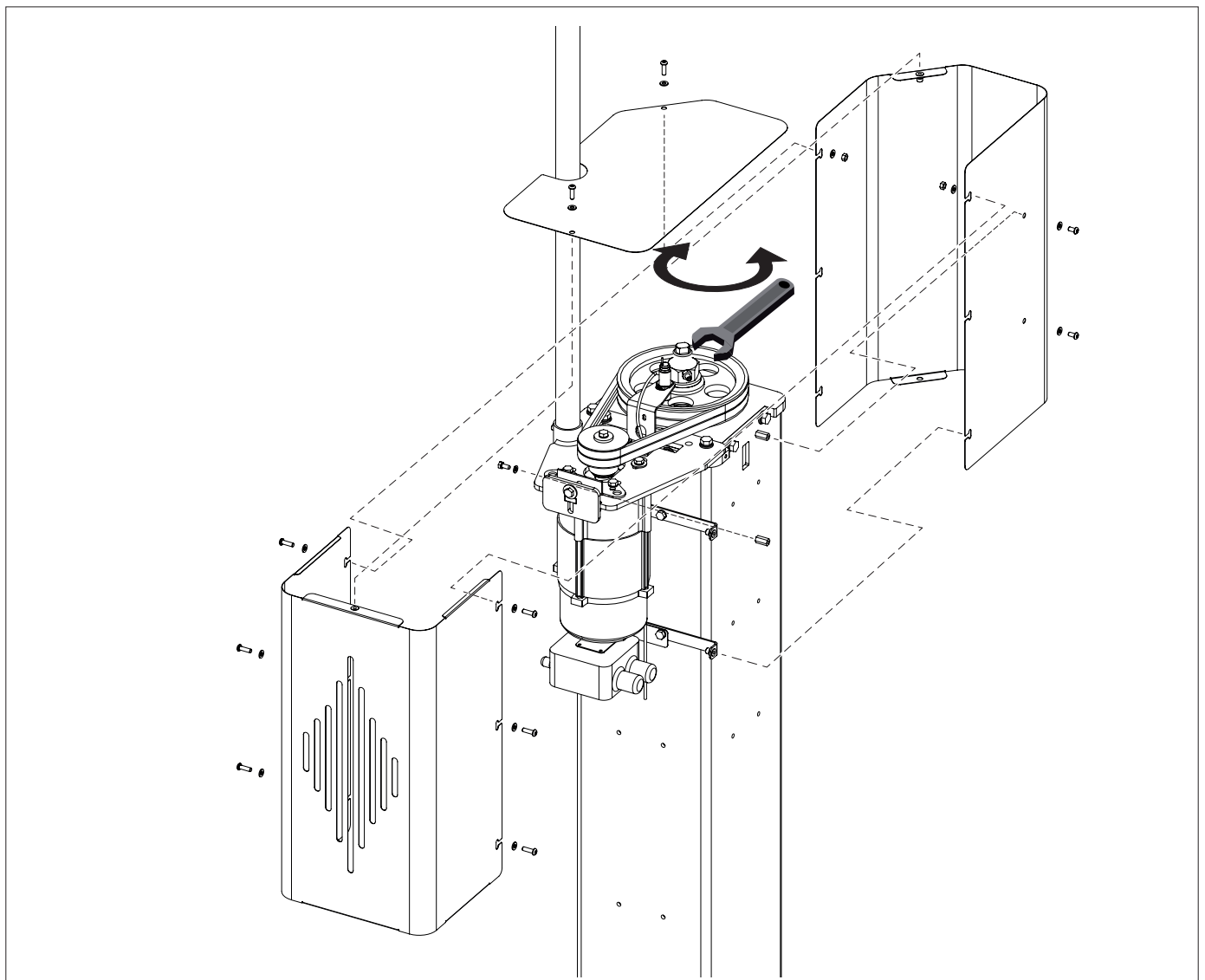

8.5 SYNCHRONISATION CONTROL DEVICE OPERATION.



Warning! Checks and emergency procedures must be carried out by a specialised technician due to the presence of electrical voltage.

The panel contains an electronic board (1) equipped with a LED (2) that stays lit when the switch is in the conditions described below:
Control box switch part no. 047303060 - 047303070

	<ul style="list-style-type: none"> • Electric circuit activated • TEqLINK activated
	<ul style="list-style-type: none"> • Push-buttons (4) and (5) deactivated • TEqLINK activated • Lockable position

Problem: lift blocked (acoustic warning).
Solution: emergency down stroke possible (single down movement).
- If the lift is blocked, it is possible to lower the carriages.

- Turn to

- Remove the cover of the electric box.
- Move lever (3) downwards in manual mode (A).

- Turn to

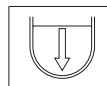

Single down movement of carriages. Activate the down stroke control and simultaneously press:

- push-button **P1** to move the carriage of the control column; push-button **P2** to move the carriage of the opposite column.

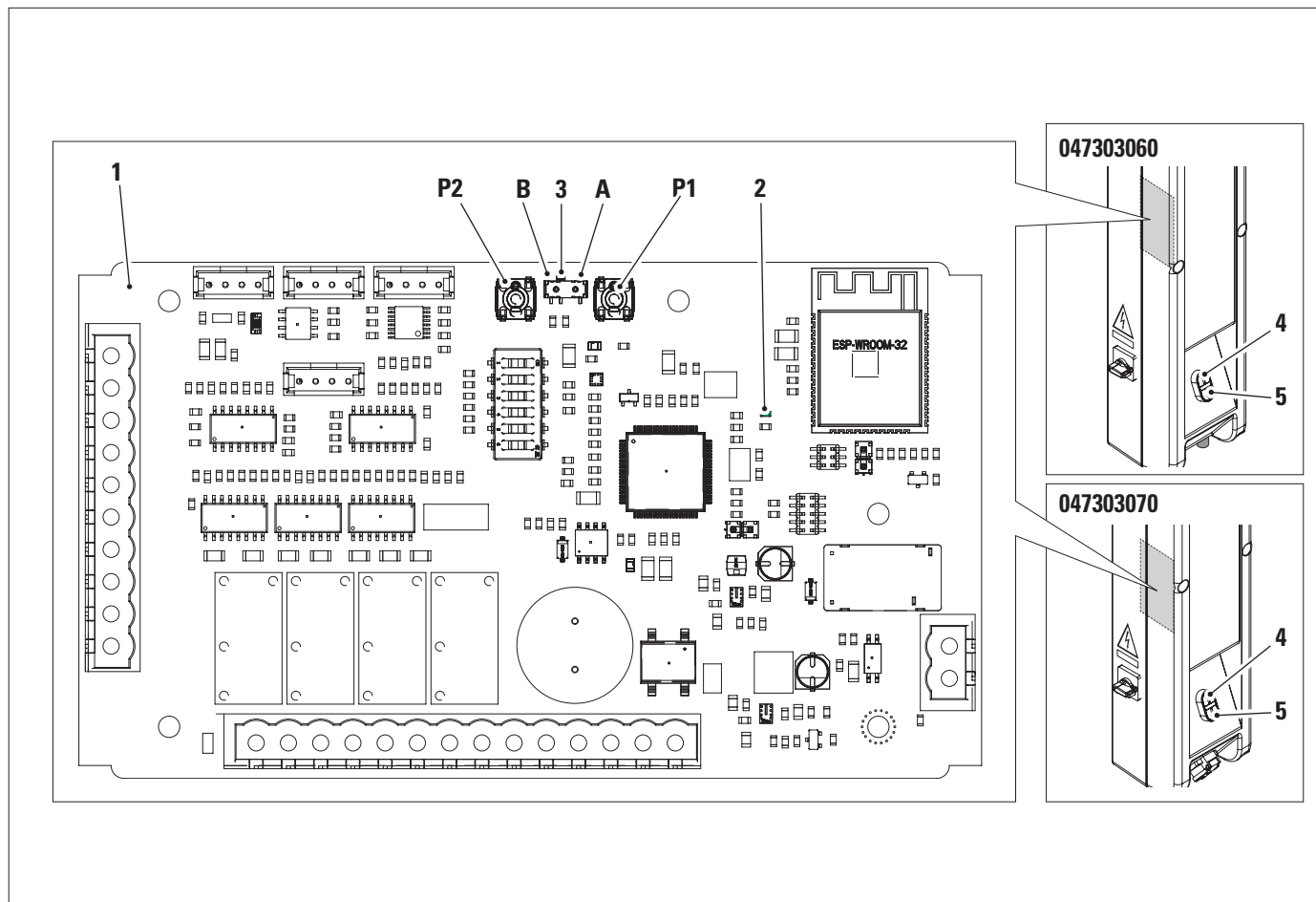



Warning: during downstroke in manual mode the carriage synchronisation system is not active. Manoeuvres to be carried out correctly and with the utmost care to avoid a dangerous misalignment of the vehicle.



- Lower both carriages, the last reaching the down stop limit resets the block status (acoustic warning off with downstroke control activated).

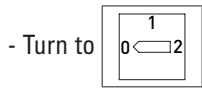

- On the board, set lever **(3)** to **(B)** (in automatic).
- Fit the cover of the electric box.

NOTE: manual mode allows only the down movement.

If the manoeuvre cannot be performed, it means that the board is in safety lock because it has detected a dangerous situation.

To reset the safety lock, proceed as follows:

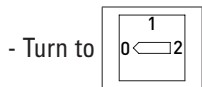

- on the board, set the lever **(3)** to **(A)** (in manual);



- press and hold the push-buttons **P1** and **P2** for 5 seconds;
- the LED **(1)**, already lit, will flash once.
- set the lever **(3)** to **(B)** (in automatic).

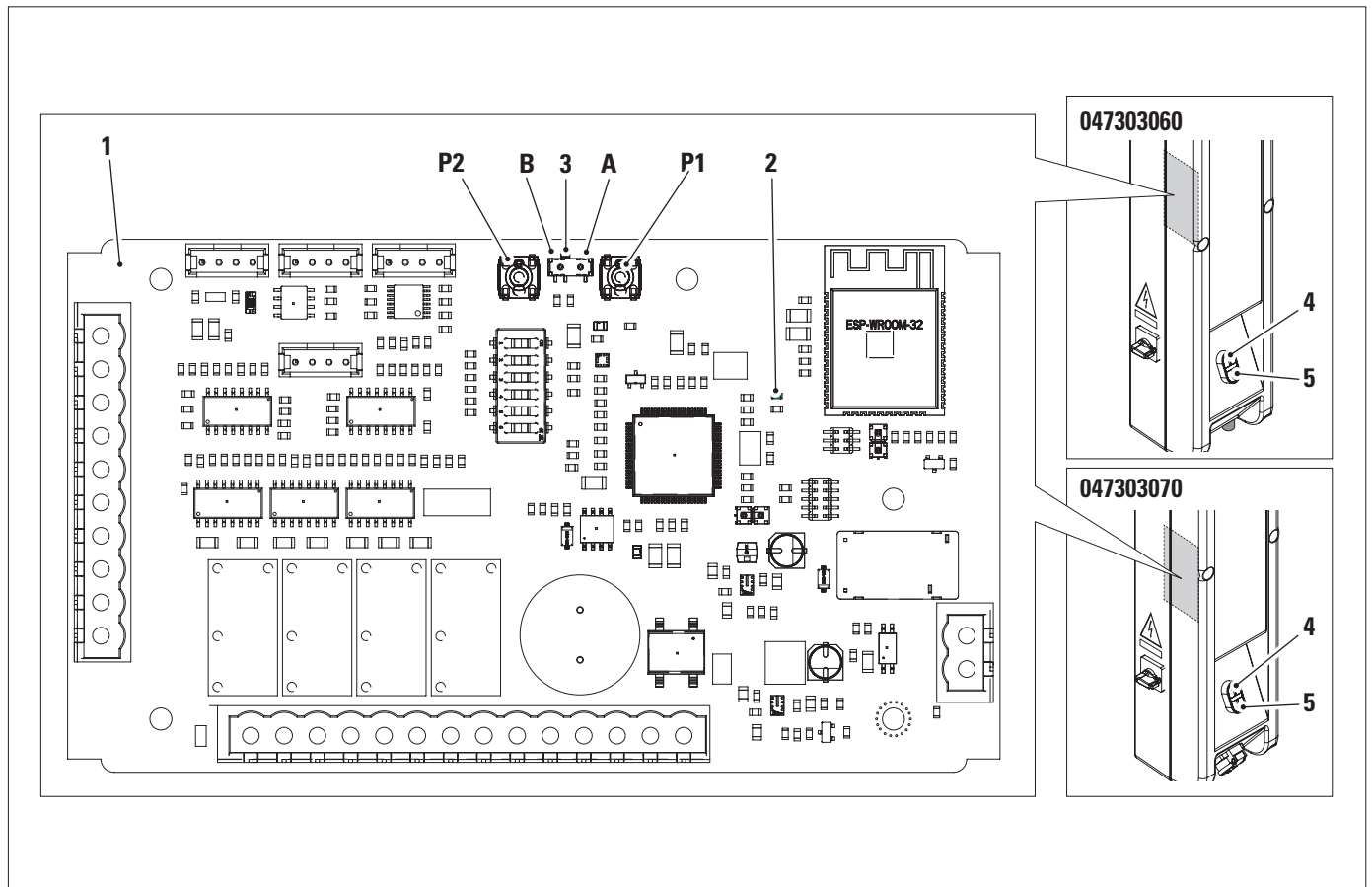

Caution:

- if the lock status was generated by a faulty hardware (board or electrical system), the lock will occur immediately again;
- if the fault is in the board, replace it;
- if the fault is in the system, remove it.



CH. 9 SAFETY DEVICES

Padlockable main switch

Control box switch part no. 047303060 - 047303070	
	<ul style="list-style-type: none"> • Electric circuit deactivated • Lockable position
	<ul style="list-style-type: none"> • Push-buttons deactivated • TEqLINK activated • Lockable position

Deadman device

The lift is equipped with a “deadman” type operative system so that up or down movement is immediately stopped when the control reverser-switch is released.

Mechanical stops

The lift is provided with mechanical stops that are activated in case of limit switch faults at the end of the up or down stroke.

In such situations, trigger the operation opposite to the previous one by a 5-10 cm stroke.

Check the concerned limit switch and replace it if necessary.

In addition to the above-mentioned mechanical stops, the deactivation of the motor temperature sensor may also occur; it will automatically reactivate after approximately 3 minutes.

Carriage height synchronization



Any unauthorised modifications or tampering with the equipment release the manufacturer from any liability for damages caused by or related to the above mentioned acts.

Removal of or tampering with safety devices constitutes an infringement of European Safety Regulations.

Should the difference in level of the two carriages exceed 18 mm, the control device automatically resets the correct alignment.

Emergency block

This type of block occurs in the case of:

- the carriages more than 40 mm out of alignment;
- motor block

Manoeuvres permitted in emergency conditions

- When the lift is in the emergency state (see previous paragraph), no operation is allowed by means of the “lowering” or “lifting” push buttons. To reset the operation mode, apply to our After Sales Service.
- To remove the car from the lift, turn the pulleys by hand.

Nut wear stop

If the lift is operated even when the limit marks are aligned (CH. 10.2), the safety system becomes operative.

The device is triggered when the carriages reach the down stop limit.

It is signalled by the acoustic warning, which is active in mode: **1s ON** and **1s OFF**.

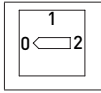
CH. 10 MAINTENANCE

When carrying out maintenance operations, set the main switch on 0 (zero).



*Caution: moving mechanical parts.
Guard removal at operator's risk*

10.1 MAINTENANCE ACTIVITIES

Carry out periodic checks on the safety devices every 3 months



The lift residual life assessment is required after 10 years of operation, to be carried out by a qualified technician, preferably authorised by the manufacturer.

• MONTHLY

Load-bearing nuts - Remove the protective curtains with the carriages 50 cm above the ground, check the nuts using the plate (1) supplied: it must be inserted in the groove as shown in the figure; if the STOP side cannot be placed correctly, replace the nut.

• EVERY THREE MONTHS

Sliding guides - Lubricate the sliding shoe guides with grease (fig. B).

Bearings - Remove the motor covers and inject grease into the grease nipples (2).

• YEARLY

Lubrication containers - Remove the protective covers and top up the lubrication containers (3) with oil (ESSO GEAR OIL 85W-140 or equivalent).

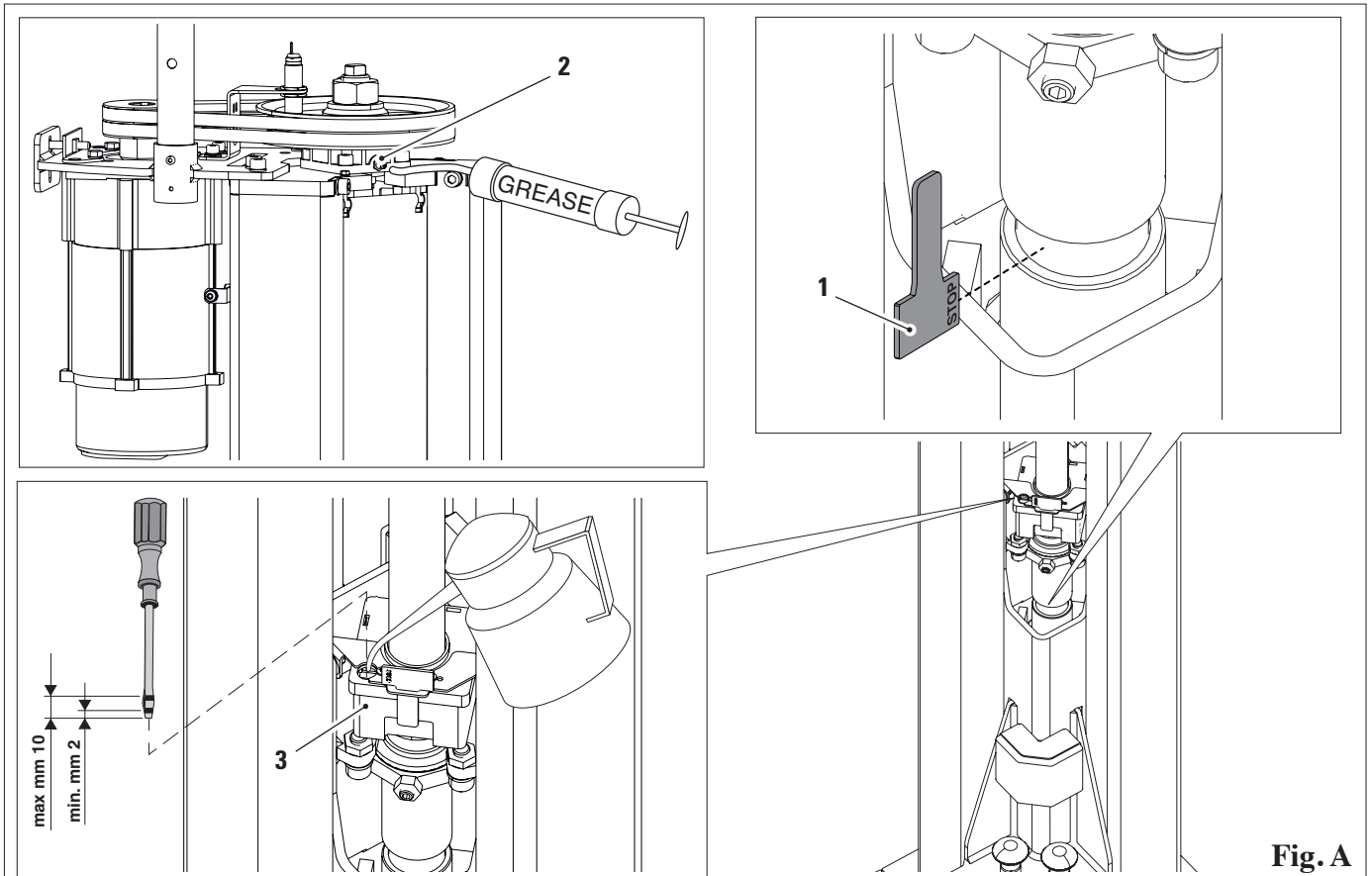
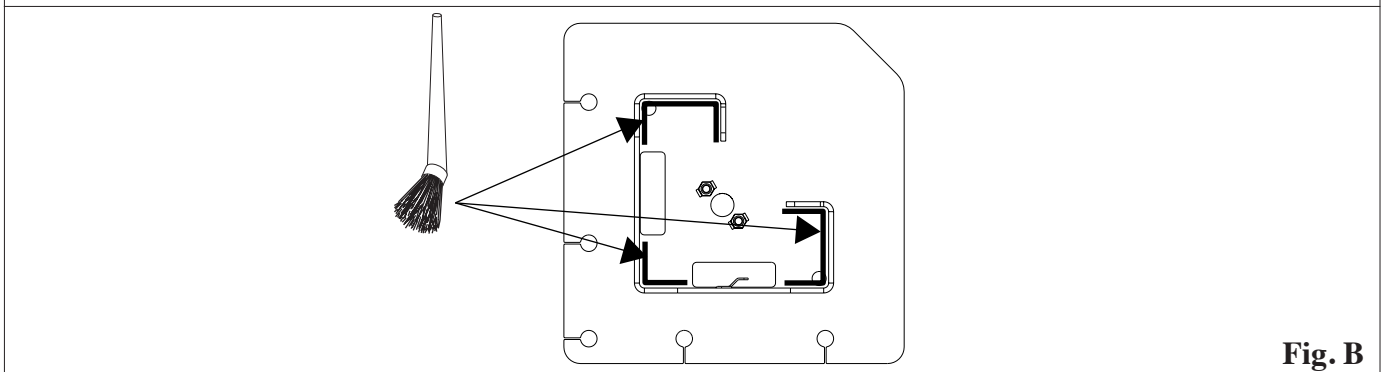
Fig. A

Fig. B

Scheduled maintenance plan

TIME interval	Type of MAINTENANCE	MAINTENANCE PLAN	POSITION*	CRITICALITY LEVEL
DAILY	STICKERS	Check and, if necessary, replace damaged or illegible safety stickers	On the column On the panel	MEDIUM
	ARMS	Check condition of foot guard, wear and tear or damage, replace if necessary	Arms	MEDIUM
	ARMS	Check condition of pads, wear and tear or damage, replace if necessary	Arms	LOW
MONTHLY	BEARING	Grease bearing screw bearing (see current caption)	At head of the screw	HIGH
	NUT	Check screw condition, wear or damage, replace if necessary (see current caption)	At the carriage head	HIGH
	NUT	Check the oil level in the lubrication container and top up with oil if necessary (see current caption)	At the carriage head	HIGH
	SAFETY NUT	Grease the safety counter nut with multi-purpose grease DO NOT use solid-based grease (Molicote), such as graphite.	At the carriage head	MEDIUM
EVERY THREE MONTHS	SLIDING GUIDES	Lubricate the carriage sliding shoe guides with grease (free of solid suspension)		HIGH
	BLOCKS	Check the anchorage after about ten strokes at full load by checking the tightening torque of the blocks.	On the column	HIGH
YEARLY	BELT	Check that the belt is correctly tensioned and that it is not worn, tension or replace if necessary.	At the column head	HIGH
	SCREW	Check screw condition, wear or damage, replace if necessary	Inside the column	HIGH
	ELECTRONIC COMPONENTS	Check condition of electric and electronic components, intact connections and damage on terminal boards or connectors	Electric panel	HIGH
	PAINTING	Check for damage and abrasions on painted surfaces sand and paint if necessary to avoid rust damages	Column Carriage	MEDIUM
	WELD JOINTS	Check for damage and cracks on weld points on column, carriage and arms. If necessary, clean the area and restore the weld point.	Column Carriage	HIGH
	RETAINING SCREWS	Check the tightness of all retaining screws If necessary, tighten with torque spanner		
	ARMS	1. Clean and lubricate the pins 2. check the pin springs and replace and repair if necessary 3. check for damages on the arms and pullout stops 4. check the arm stop system, threads and wear; replace if necessary	Arms	MEDIUM
	SLIDING SHOES	Check the sliding shoes and guides for damage and wear. If necessary, replace and shim the sliding shoes, cleaning the area and lubricating	Carriage unit	MEDIUM

10.2 NUT WEAR AND REPLACEMENT OF SCREW ASSEMBLY

Bearing nut wear leads to its breakage, in which case the carriage position will be 20mm lower. This condition is detected by the electronic board when the down limit stops are activated, signalled by the acoustic warning device operating in 1sec. ON - 1sec. OFF. Consequently, the up stroke cannot take place. Nut breakage requires the replacement of the entire screw assembly.

Screw assembly replacement procedure:

- Bring the carriage to a height of approx. 350mm and insert a block of wood (1) under the carriage.
- Disconnect the machine power supply.
- Remove the curtain (2).
- Remove the covers (3).
- Remove the proximity support (4) (caution: not the proximity from its support).
- Remove the drive belts (5).
- Turn the pulley until the carriage is in contact with the block of wood (fig. C).
- Remove anti-rotation tray (6).
- Remove grub screw and nut (7).
- Remove retaining screws (8).
- Remove bearing support screws (9).
- Rotate the nut until it is flush with the safety nut (clockwise) (10).
- Screw the eye bolt into the end of the screw (11).
- Remove the screw assembly from inside the lift with a diagonal movement (fig. D).
- Carry out the steps in the reverse direction to fit the spare part (paying close attention to securing the grub screw).

Carry out the RESET refer to chapter 8.5.

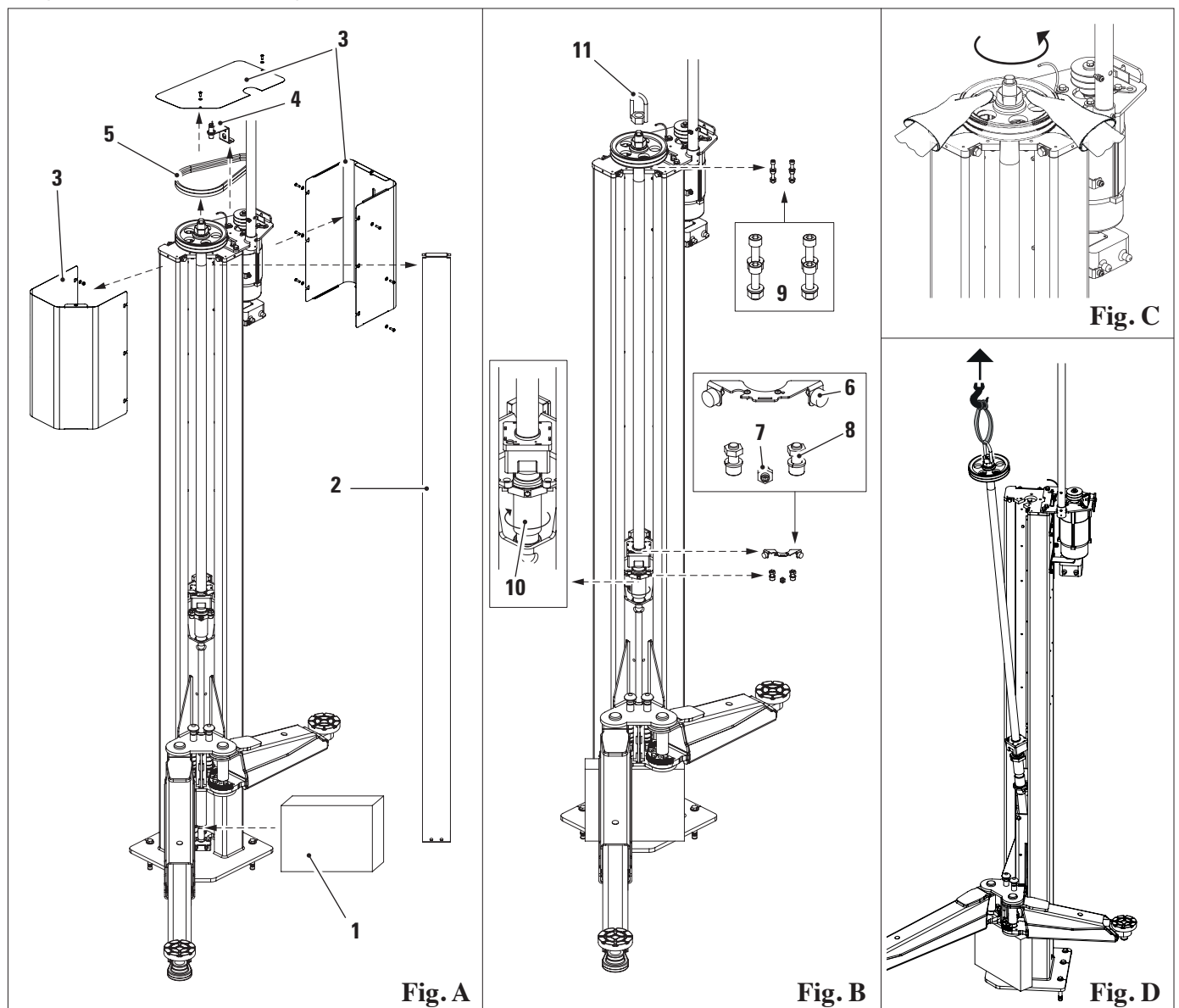

10.3 TROUBLE SHOOTING

Certain problems which may arise while using the lift are listed below. ROTARY cannot accept any liability for injury to people or animals and damage to things caused by unauthorised staff using the equipment. In the event of faults, you are advised to contact the technical service department in good time to receive advice about how to carry out work and/or adjustments in maximum safety conditions, thus avoiding the risk of injury to people or animals and damage to things.



Technical service staff are required. Intervention by others prohibited.



PROBLEM	POSSIBLE CAUSE	REMEDY
No operation. Acoustic warning off.	Power supply voltage.	Check the voltage in the power supply cables. Check lift switch / reversing device. Check line fuses. Check control transformer and its fuses.
It does not complete the stroke. Acoustic warning off.	Deactivation of motor temperature sensor.	Wait for reactivation.
No operation. Acoustic warning on.	Lift in emergency stop. Proximity switch. Motor at stop.	Refer to chapter 8.5 Adjust / replace. Check motor belts.
No operation. Acoustic warning on: 2sec. ON / 2 sec. OFF	Board switch in manual after block reset.	Turn switch to automatic.
The carriages do not lift at down limit stop. Acoustic warning on: 1sec. ON / 1 sec. OFF	Stop for nut wear.	Refer to chapter 10.2.
No operation, not even in manual mode. Acoustic warning on.	Safety stop.	Refer to chapter 8.5

CH. 11 WASTE DISPOSAL-DISMANTLING

11.1 DISASSEMBLING

Disassembly work can only be carried out by authorised specialised personnel. Only qualified electricians may work on the electrical system.

- To carry out dismantling work, switch off the device with the main switch (OFF position).
- Disconnect the power supply.
- Empty the oil tank. Dispose of hydraulic and operating fluids as described in chapter 11.3.
- Remove grease and other chemicals. Dispose as described in chapter 11.3
- Dismantling operations must be carried out in the reverse order of the assembly steps (refer to ch. 7).

11.2 STORAGE

- In the event of the lift having to be stored for long periods, disconnect the power supply, empty the tank/s containing liquids used for machine operation and protect any parts that might be damaged by dust.
- Grease the parts that might be damaged by dryness.
- When the machine is started again, replace the seals indicated in the spare parts section.

11.3 WASTE DISPOSAL

Environmental procedures for disposal Prevent environmental hazards.

Avoid contact with or inhalation of toxic substances such as hydraulic fluid.

Oils and lubricants are water pollutants within the terms of the WGH Water Resources Act. Always dispose of these in an environmentally friendly manner in compliance with the regulations in your country.

Mineral oil-based hydraulic fluid is a water pollutant and is combustible. Please refer to the safety data sheet for disposal.

Make sure that no hydraulic fluid, lubricants or cleaning materials contaminate the soil or are disposed of in the sewage system.

Packaging

Do not dispose of with household waste! The packaging contains some recyclable materials, which must not be disposed of with household waste.

- Dispose of packaging materials in accordance with local regulations.

Oil, grease and other chemicals.

- When handling oil, grease and other chemicals, comply with the environmental regulations that apply to the product in question.
- Dispose of oil, grease and other chemicals in accordance with the environmental regulations that apply in your country.

Metals / Electronic waste

These must always be properly disposed of by a certified company.

INSTALLATION REPORT

**CONTROL OPERATION
TO BE COMPLETED BY THE FITTER**

Lift model _____

Serial number _____

- | | |
|---|--------------------------|
| | <input type="checkbox"/> |
| Checking the floor | <input type="checkbox"/> |
| Power voltage check | <input type="checkbox"/> |
| Main switch | <input type="checkbox"/> |
| Up/down control | <input type="checkbox"/> |
| Correct trolley movement - operation control | <input type="checkbox"/> |
| End of downward movement operation control | <input type="checkbox"/> |
| Block tightening torque check | <input type="checkbox"/> |
| Telescopic arms correct sliding control | <input type="checkbox"/> |
| Correct arm stop engagement and release control | <input type="checkbox"/> |
| Screw lubrication device level control | <input type="checkbox"/> |
| Slide guide lubrication control | <input type="checkbox"/> |
| Adhesive and adhesive position check | <input type="checkbox"/> |
| Carrying capacity | <input type="checkbox"/> |
| Warnings | <input type="checkbox"/> |
| Serial number | <input type="checkbox"/> |

Fitter's signature and stamp

Installation date

PERIODICAL VISIT

Control operation	date		signature		date		signature		date		signature	
Main nut wear check	<input type="checkbox"/>		<input type="checkbox"/>		<input type="checkbox"/>		<input type="checkbox"/>		<input type="checkbox"/>		<input type="checkbox"/>	
Main switch	<input type="checkbox"/>		<input type="checkbox"/>		<input type="checkbox"/>		<input type="checkbox"/>		<input type="checkbox"/>		<input type="checkbox"/>	
Up/down control	<input type="checkbox"/>		<input type="checkbox"/>		<input type="checkbox"/>		<input type="checkbox"/>		<input type="checkbox"/>		<input type="checkbox"/>	
End of downward movement operation control	<input type="checkbox"/>		<input type="checkbox"/>		<input type="checkbox"/>		<input type="checkbox"/>		<input type="checkbox"/>		<input type="checkbox"/>	
Block tightening torque check	<input type="checkbox"/>		<input type="checkbox"/>		<input type="checkbox"/>		<input type="checkbox"/>		<input type="checkbox"/>		<input type="checkbox"/>	
Telescopic arms correct sliding control	<input type="checkbox"/>		<input type="checkbox"/>		<input type="checkbox"/>		<input type="checkbox"/>		<input type="checkbox"/>		<input type="checkbox"/>	
Correct arm stop engagement and release control	<input type="checkbox"/>		<input type="checkbox"/>		<input type="checkbox"/>		<input type="checkbox"/>		<input type="checkbox"/>		<input type="checkbox"/>	
Screw lubrication device level control	<input type="checkbox"/>		<input type="checkbox"/>		<input type="checkbox"/>		<input type="checkbox"/>		<input type="checkbox"/>		<input type="checkbox"/>	
Slide guide lubrication control	<input type="checkbox"/>		<input type="checkbox"/>		<input type="checkbox"/>		<input type="checkbox"/>		<input type="checkbox"/>		<input type="checkbox"/>	
Adhesive and adhesive position check	<input type="checkbox"/>		<input type="checkbox"/>		<input type="checkbox"/>		<input type="checkbox"/>		<input type="checkbox"/>		<input type="checkbox"/>	
Check conditions of lifting pads	<input type="checkbox"/>		<input type="checkbox"/>		<input type="checkbox"/>		<input type="checkbox"/>		<input type="checkbox"/>		<input type="checkbox"/>	
Carrying capacity	<input type="checkbox"/>		<input type="checkbox"/>		<input type="checkbox"/>		<input type="checkbox"/>		<input type="checkbox"/>		<input type="checkbox"/>	
Warnings	<input type="checkbox"/>		<input type="checkbox"/>		<input type="checkbox"/>		<input type="checkbox"/>		<input type="checkbox"/>		<input type="checkbox"/>	
Serial number	<input type="checkbox"/>		<input type="checkbox"/>		<input type="checkbox"/>		<input type="checkbox"/>		<input type="checkbox"/>		<input type="checkbox"/>	

INDICE

CAP. 1	SIMBOLOGIA UTILIZZATA NEL MANUALE	IT_2
CAP. 2	PRESENTAZIONE.....	IT_3
2.1	DESCRIZIONE DEL SOLLEVATORE	IT_3
2.2	DESTINAZIONE D'USO	IT_3
CAP. 3	DATI TECNICI.....	IT_4
3.1	CARATTERISTICHE TECNICHE PRINCIPALI	IT_4
3.2	DATI TECNICI GENERALI	IT_5
3.3	DATI DI IDENTIFICAZIONE DELLA MACCHINA.....	IT_7
3.4	COMANDI PRINCIPALI DEL SOLLEVATORE.....	IT_8
3.5.	IMPIANTO ELETTRICO	IT_9
CAP. 4	NORME GENERALI DI SICUREZZA.....	IT_17
4.1	INDICAZIONI DEI RISCHI RESIDUI.....	IT_17
4.2	TARGHETTE E/O ADESIVI DI SICUREZZA	IT_17
4.3	ADDESTRAMENTO DEL PERSONALE PREPOSTO	IT_17
4.4	ATTITUDINE ALL'IMPIEGO	IT_17
CAP. 5	REQUISITI PER L'INSTALLAZIONE	IT_18
5.1	REQUISITI MINIMI RICHIESTI PER LUOGO DI INSTALLAZIONE	IT_18
5.2	REQUISITI DELLA PAVIMENTAZIONE	IT_19
CAP. 6	MOVIMENTAZIONE E PREINSTALLAZIONE	IT_20
CAP. 7	INSTALLAZIONE.....	IT_21
7.1	TASSELLI	IT_21
7.2	CALCESTRUZZO.....	IT_21
7.3	ISTRUZIONI PER L'INSTALLAZIONE.....	IT_22
7.4	CONTROLLO TENSIONE.....	IT_23
7.5	ALLACCIAMENTO RETE.....	IT_23
7.6	COLLEGAMENTI	IT_23
7.7	COMPLETAMENTO E CONTROLLO	IT_24
7.8	MONTAGGIO BRACCI.....	IT_25
7.9	USO DI ACCESSORI.....	IT_25
CAP. 8	USO DEL SOLLEVATORE.....	IT_26
8.1	PRECAUZIONI D'USO	IT_26
8.2	MOVIMENTAZIONE E COMPORTAMENTO DURANTE LE FUNZIONI DEL SOLLEVATORE.....	IT_26
8.3	IDENTIFICAZIONE DEI COMANDI E LORO FUNZIONI.....	IT_27
8.4	USO IMPROPRIO DEL SOLLEVATORE.....	IT_28
8.5	FUNZIONALITÀ DISPOSITIVO DI CONTROLLO SINCRONIZZAZIONE.....	IT_29
CAP. 9	DISPOSITIVI DI SICUREZZA	IT_31
CAP. 10	MANUTENZIONE.....	IT_32
10.1	ATTIVITÀ DI MANUTENZIONE.....	IT_32
10.2	USURA CHIOCCIOLA E SOSTITUZIONE GRUPPO VITE	IT_34
10.3	TROUBLE SHOOTING.....	IT_35
CAP. 11	SMALTIMENTO-ROTTAMAZIONE.....	IT_35
11.1	SMONTAGGIO	IT_35
11.2	ACCANTONAMENTO	IT_35
11.3	SMALTIMENTO.....	IT_35
	RAPPORTO DI INSTALLAZIONE.....	IT_36
	VISITA PERIODICA.....	IT_37
	MANUTENZIONI STRAORDINARIE E RIPARAZIONI.....	IT_38

ATTENZIONE!

- Il presente manuale costituisce parte integrante del prodotto, dovrà seguire tutta la vita operativa del sollevatore.
- Conservarlo, quindi, in luogo noto e a portata di mano per poterlo consultare ogni qualvolta sorgano dubbi.
- L'utilizzo del sollevatore è consentito esclusivamente a personale adeguatamente istruito che abbia letto e compreso il presente manuale.
- Ogni danno derivante dalla mancata osservanza delle indicazioni contenute nel presente manuale e da un uso improprio del sollevatore esime la ROTARY da ogni responsabilità.

CAP. 1 SIMBOLOGIA UTILIZZATA NEL MANUALE

	Attenzione!		Obbligatorio consultare il manuale/ libretto di istruzioni
	Pericolo elettricità		Personale specializzato
	Pericolo carichi sospesi		Obbligo
	Pericolo carrelli elevatori ed altri veicoli industriali		Vietato passare e sostare sotto i carichi sospesi
	Pericolo organi in movimento		Usare scarpe protettive
	Pericolo schiacciamento mani		Usare i guanti
	Sollevamento dall'alto		Usare indumenti protettivi
	Vietato		Usare gli occhiali
			Obbligatorio disconnettere prima di effettuare manutenzioni o riparazioni

CAP. 2 PRESENTAZIONE

2.1 DESCRIZIONE DEL SOLLEVATORE

- Nome prodotto: SOLLEVATORE PER AUTOVEICOLI
- Descrizione prodotto: Sollevatore elettromeccanico a due colonne con bracci telescopici.
Ponte per sollevamento allo chassis

2.2 DESTINAZIONE D'USO

Il prodotto è destinato al sollevamento di autoveicoli come previsto dalla normativa vigente, Direttiva Macchine 2006/42/CE ; la portata è quella indicata nella targhetta matricola.

Il sollevatore è stato progettato per ambienti interni non soggetti all'azione del vento.

E' consentito il sollevamento di autoveicoli rispondenti ai seguenti requisiti:

- peso non superiore alla portata del sollevatore (vedi fig. **A**) come previsto dalla normativa UNI EN 1493:2010
- il sollevatore è rispondente alla ripartizione di carico 2/5 – 3/5 ed alla condizione di reversibilità espresse dalla 1493:2010 (fig. **B**).
- distanza minima dei punti di sollevamento: mm.1000 (Fig. **C**).

Per valori di distanza inferiori, la portata del sollevatore viene ridotta. Pertanto in questi casi o per altri non contemplati nel presente manuale, sarà opportuno contattare il costruttore.

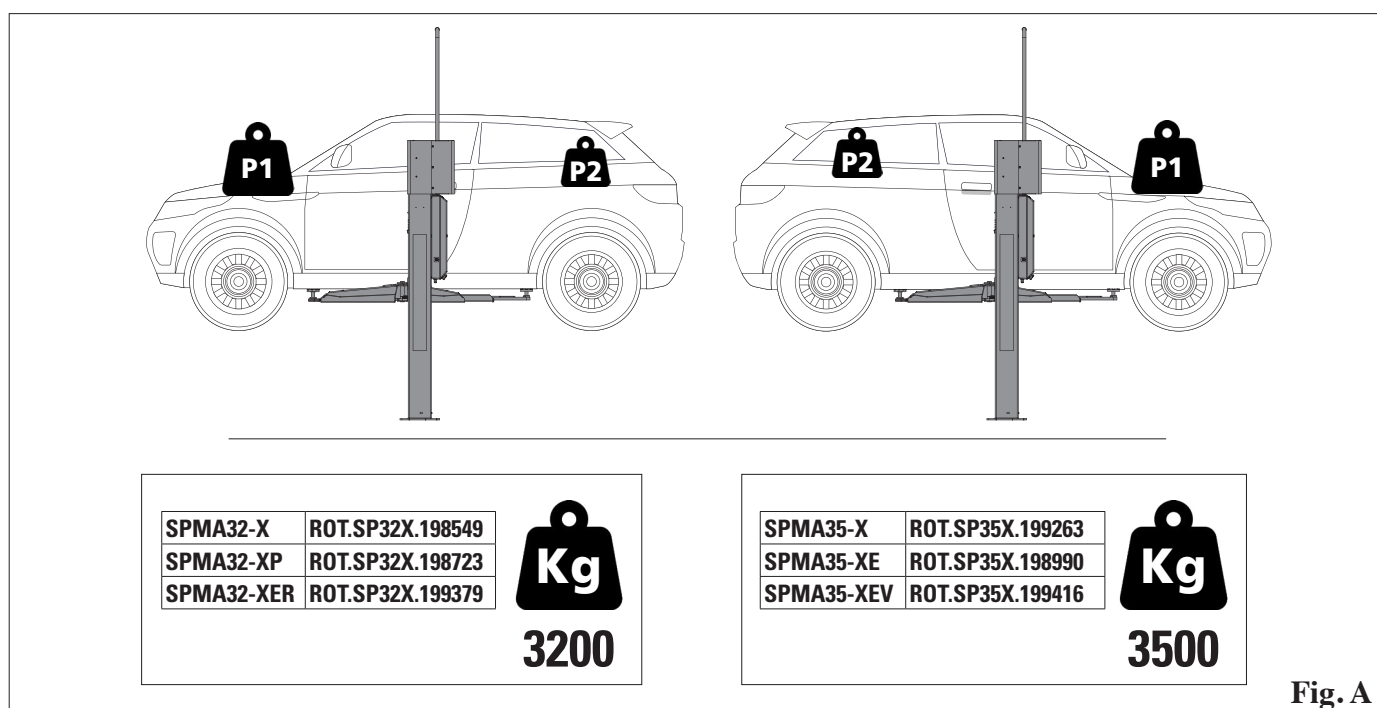
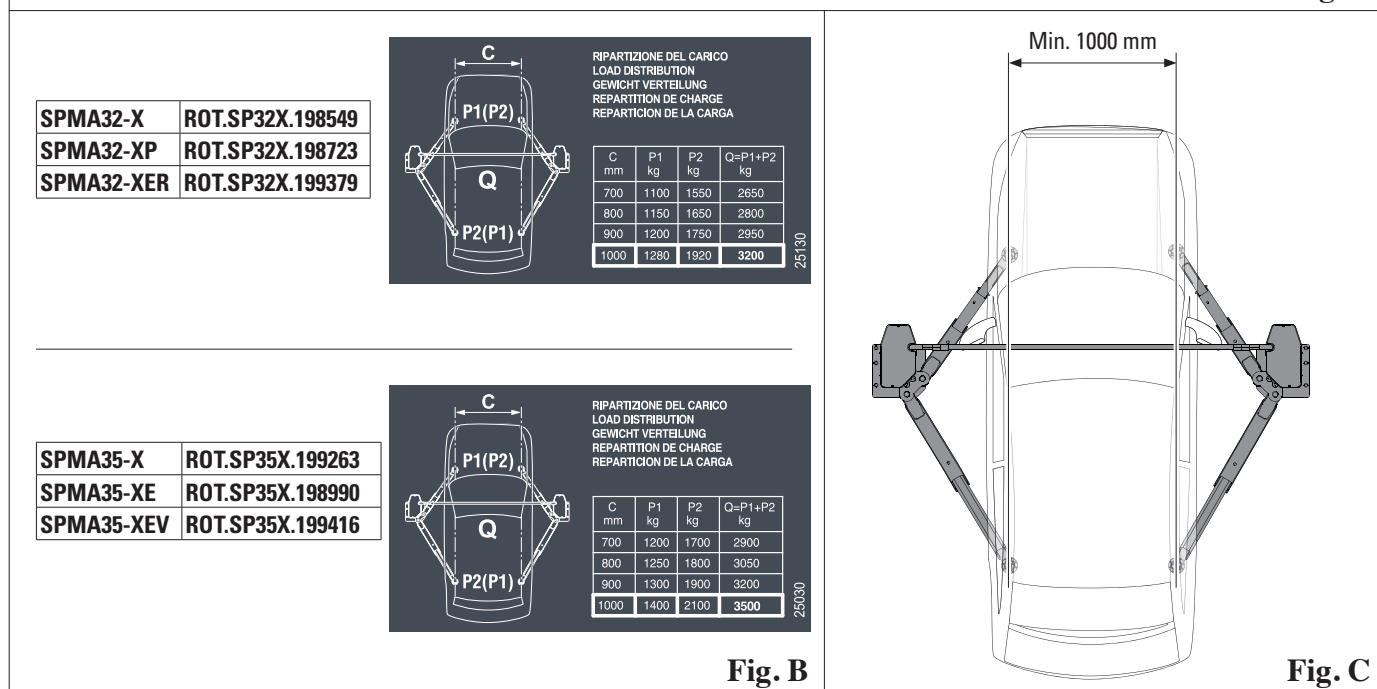
Fig. A

Fig. B
Fig. C

CAP. 3 DATI TECNICI

3.1 CARATTERISTICHE TECNICHE PRINCIPALI

Traslazione carrelli su pattini in tecnopolimero ad alta resistenza e basso coefficiente di attrito.

Movimenti di sollevamento e abbassamento ottenuti tramite chiocciolate portanti in bronzo accoppiate con viti di manovra a passo fine a garanzia della irreversibilità dei movimenti.

Dispositivo di sicurezza elettronico atto ad impedire ulteriori corse di sollevamento in caso di usura completa della chiocciola portante.

Lubrificazione automatica delle viti di manovra ad ogni corsa.

Riallineamento dei carrelli ottenuto mediante dispositivo elettronico.

Dispositivo di blocco per disallineamento dei carrelli superiori la quota di 30 mm.

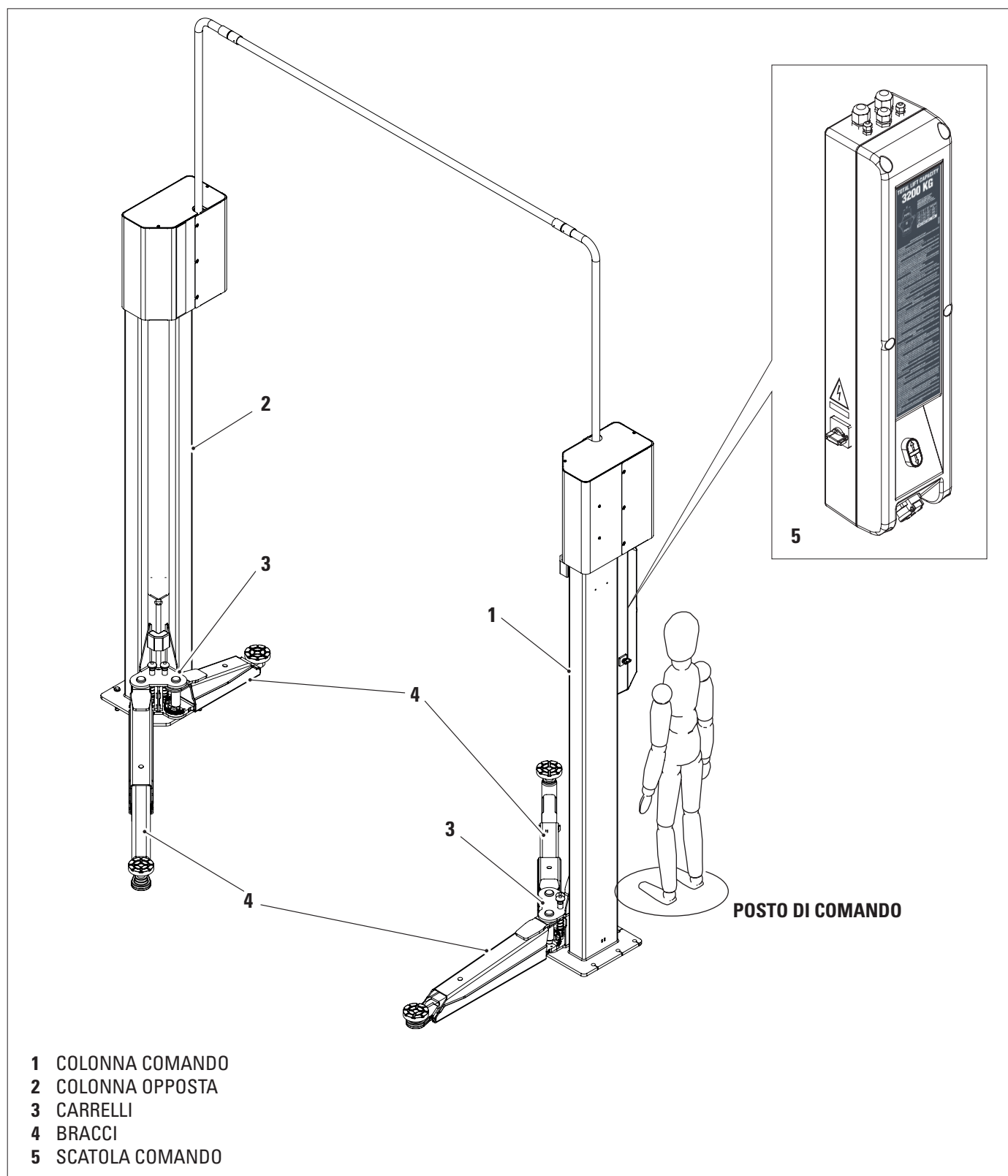

3.2 DATI TECNICI GENERALI
SPMA32

	Numero di colonne	2	D Passaggio	2472 mm	F Altezza minima tamponi	96 mm
	Capacità di sollevamento	3200 kg	Braccio Anteriore Min.	555 mm	Altezza di sollevamento massima	2000 mm
	Altezza minima soffitto	4150 mm	Braccio Anteriore Max.	1100 mm	Rialzo	1860 mm
	A Altezza totale	4052 mm	Braccio Posteriore Min.	805 mm	Tempo salita/discesa	42 secs.
	B Colonne esterne	3223 mm	Braccio Posteriore Max.	1200 mm	Alimentazione	400 V 50 Hz 3Ph
	C Colonne interne	2700 mm	E Altezza massima tamponi	130 mm	Potenza motrice	2x2.6 Kw

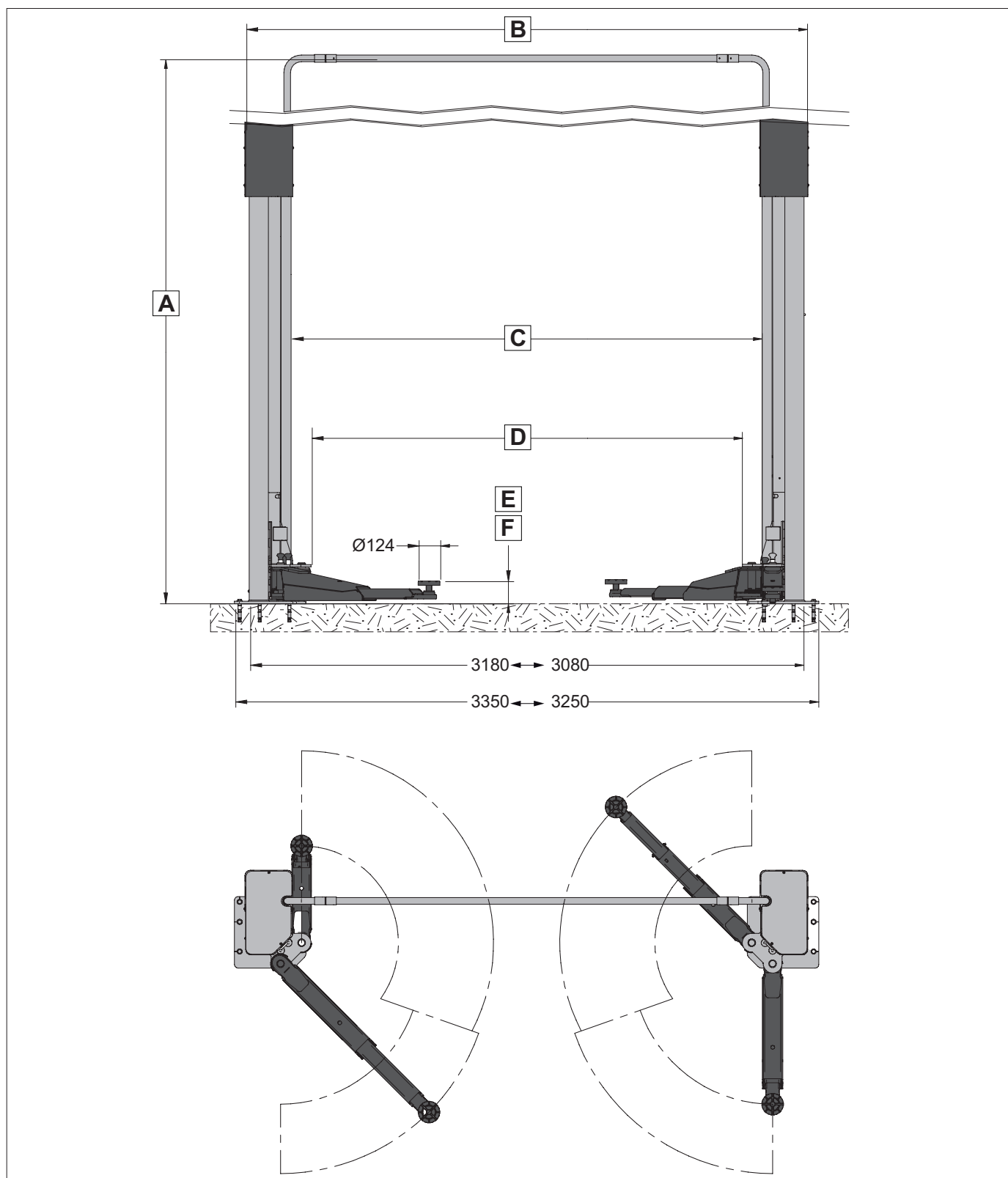

SPMA35

Numero di colonne	2	D Passaggio	2472 mm	Altezza di sollevamento massima	2012 mm
Capacità di sollevamento	3500 kg	Braccio Anteriore Min.	564 mm	Rialzo	1863 mm
Altezza minima soffitto	4150 mm	Braccio Anteriore Max.	1160 mm	Tempo salita/discesa	42 secs.
A Altezza totale	4052 mm	Braccio Posteriore Min.	922 mm	Alimentazione	400 V 50 Hz 3Ph
B Colonne esterne	3223 mm	Braccio Posteriore Max.	1460 mm	Potenza motrice	2x2.6 Kw
C Colonne interne	2700 mm	E Altezza massima tamponi	150 mm		
		F Altezza minima tamponi	100 mm		

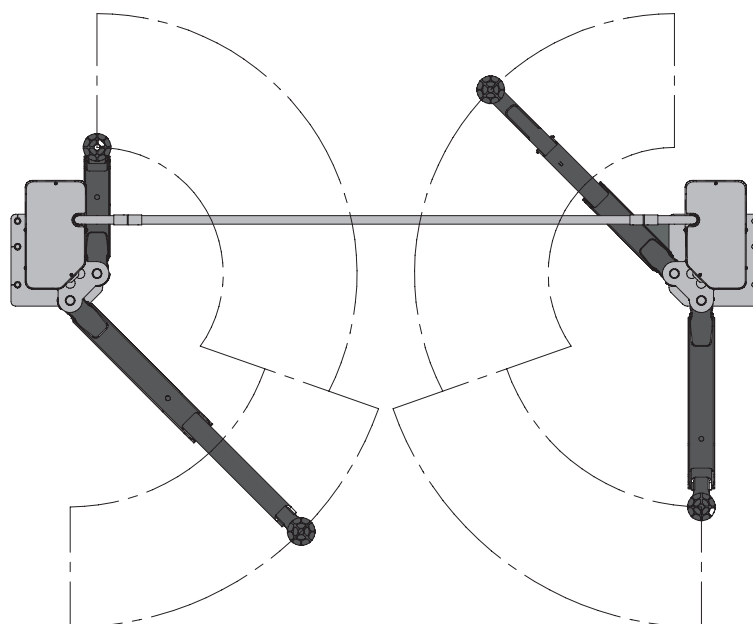
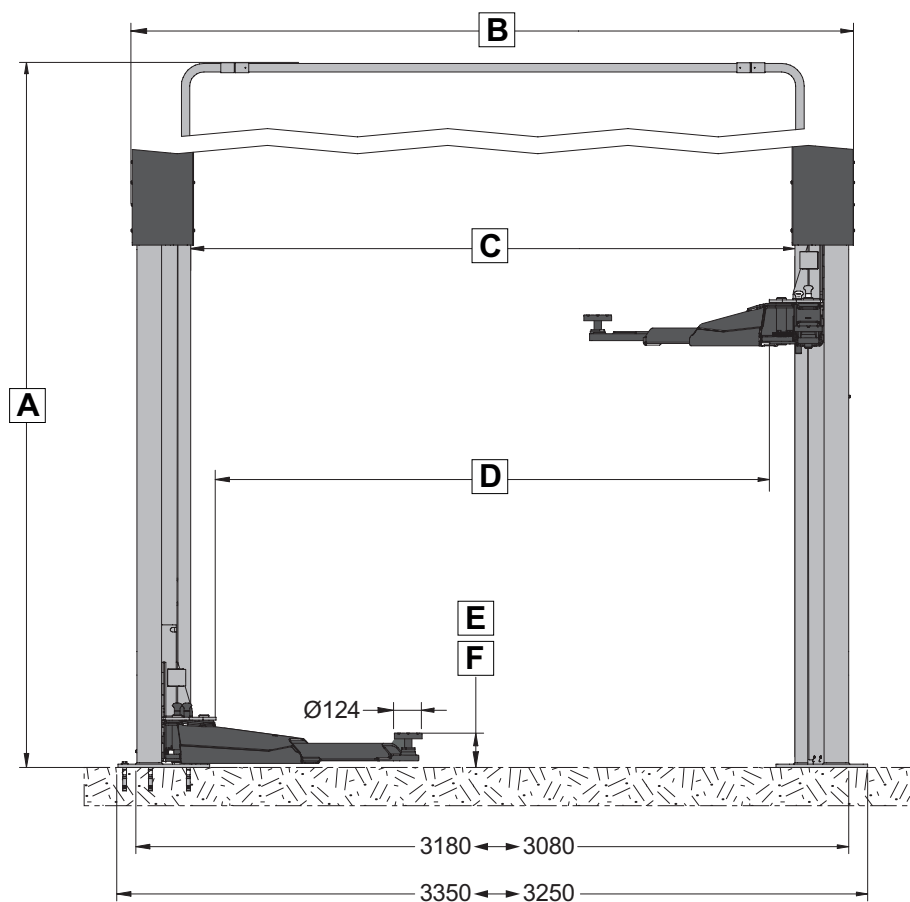

DATI FONOMETRICI
RUMOROSITÀ

	Rif	Distanza (m)	Lp dB(A)	Lpk dB(C)	U dB
	1	0,6	≤ 70dB(A)	≤ 130dB(C)	
2	1,0	73	≤ 130dB(C)		

3.3 DATI DI IDENTIFICAZIONE DELLA MACCHINA

Sul carrello della colonna comando si trova la targhetta di identificazione del sollevatore, sulla quale sono riportati i seguenti dati:

- A** Costruttore
- B** Portata sollevatore
- C** Numero di matricola
- D** Anno di costruzione
- E** Modello

ATTENZIONE: E' assolutamente vietato manomettere, incidere, alterare in qualsiasi modo od addirittura asportare la targa di identificazione della macchina; non coprire la presente targa con, pannellature provvisorie ecc. in quanto deve risultare sempre ben visibile.

Mantenere detta targa sempre ben pulita da grasso o sporcizia in genere.

AVVERTENZA: Nel caso in cui per motivi accidentali la targa di identificazione risultasse danneggiata (staccata dalla macchina, rovinata od illeggibile anche parzialmente) notificare immediatamente l'accaduto alla ditta costruttrice.

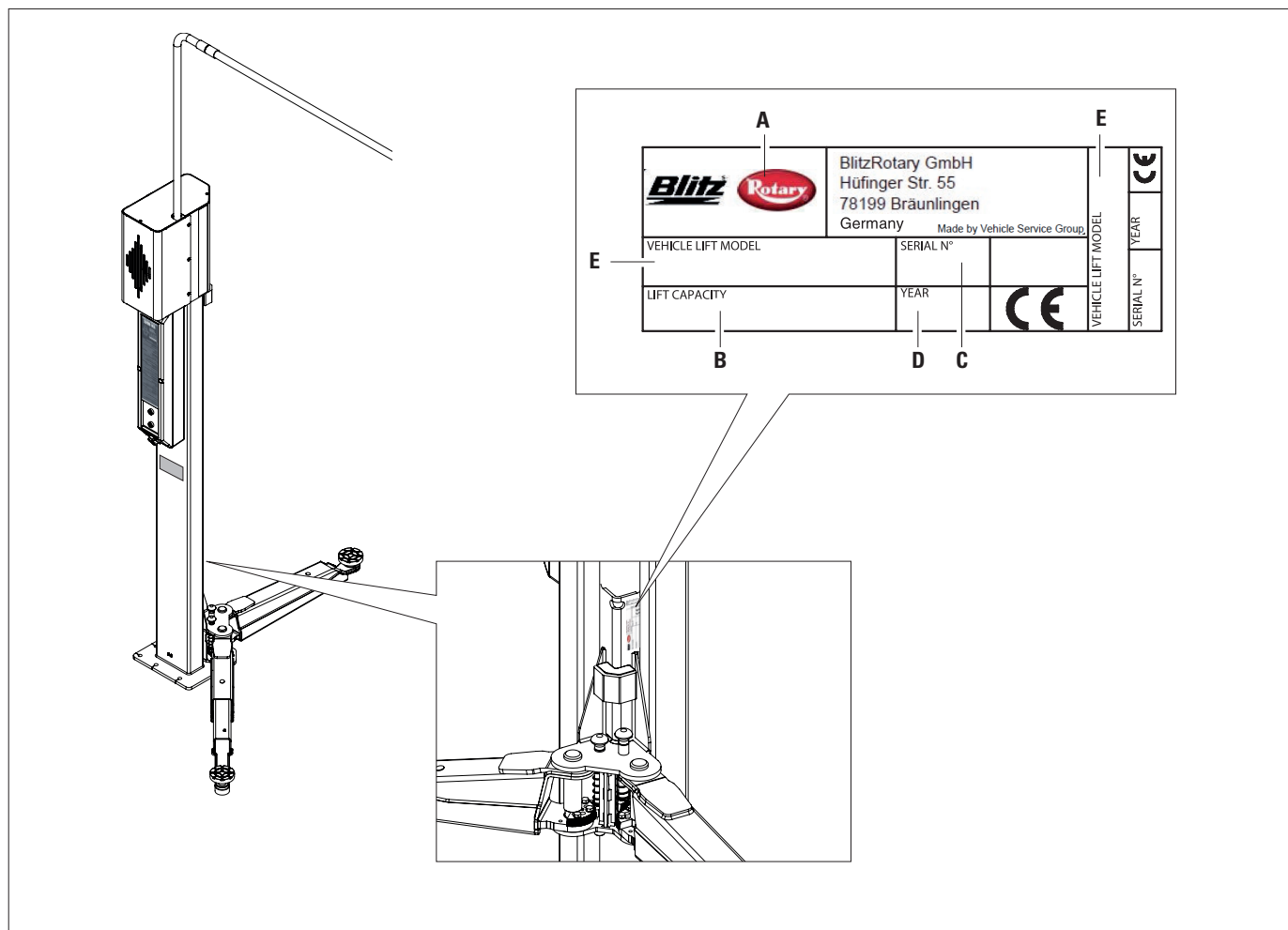

3.4 COMANDI PRINCIPALI DEL SOLLEVATORE

I comandi principali si trovano nella scatola comando che cambia a seconda del modello. Vedi schema di comparazione.

MODELLO	CODICE PN	CODICE SCATOLA COMANDO	CODICE SCATOLA DI DERIVAZIONE	CODICE IMPIANTO ELETTRICO
SPMA32-X	ROT.SP32X.198549	047303060	047303021	047305510
SPMA32-XP	ROT.SP32X.198723	047303070	047303080 (scatola comando)	047305530
SPMA32-XER	ROT.SP32X.199379	047303070	047303080 (scatola comando)	047305530
SPMA35-X	ROT.SP35X.199263	047303060	047303021	047305510
SPMA35-XE	ROT.SP35X.198990	047303070	047303080 (scatola comando)	047305530
SPMA35-XEV	ROT.SP35X.199416	047303070	047303080 (scatola comando)	047305530

047303060

Scatola comando con interruttore e pulsanti salita e discesa.

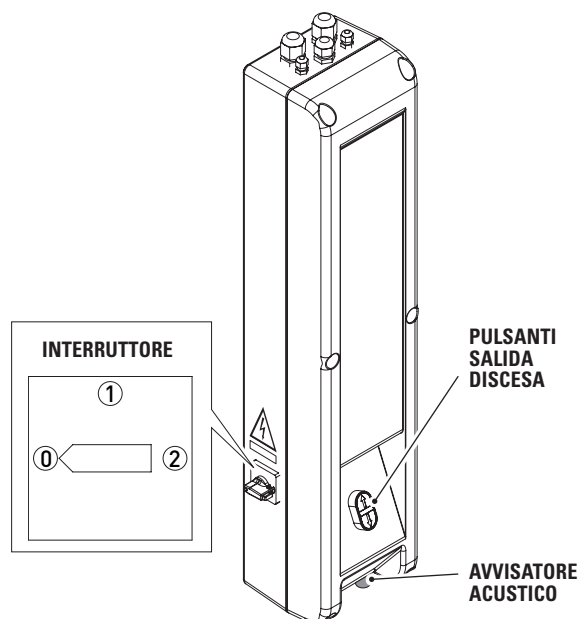
047303070 / 047303080

Doppia scatola comando con interruttore, pulsanti salita e discesa, pulsante di emergenza.

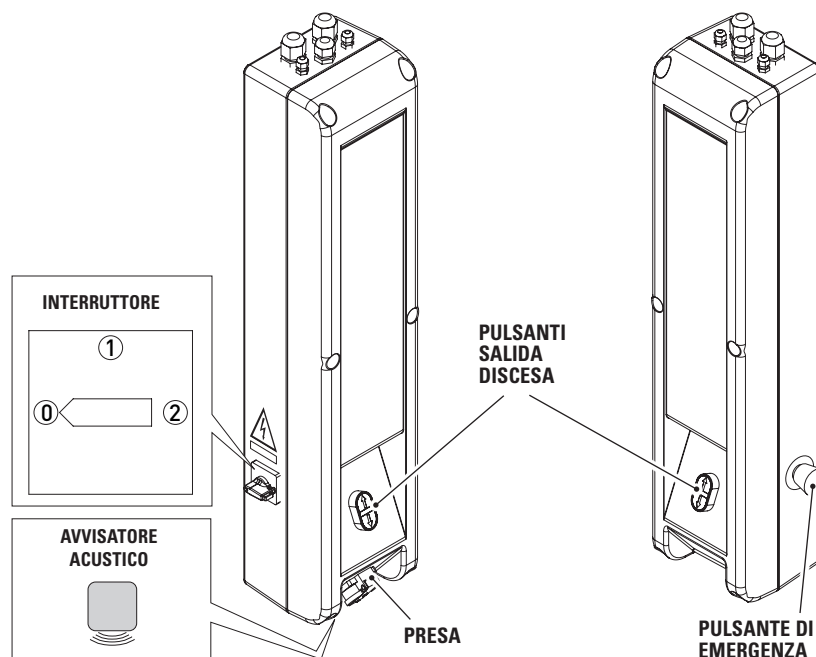

3.5. IMPIANTO ELETTRICO

Installazione da eseguire dall'utilizzatore

CODICE IMPIANTO ELETTRICO: 047305510

Alimentazione elettrica

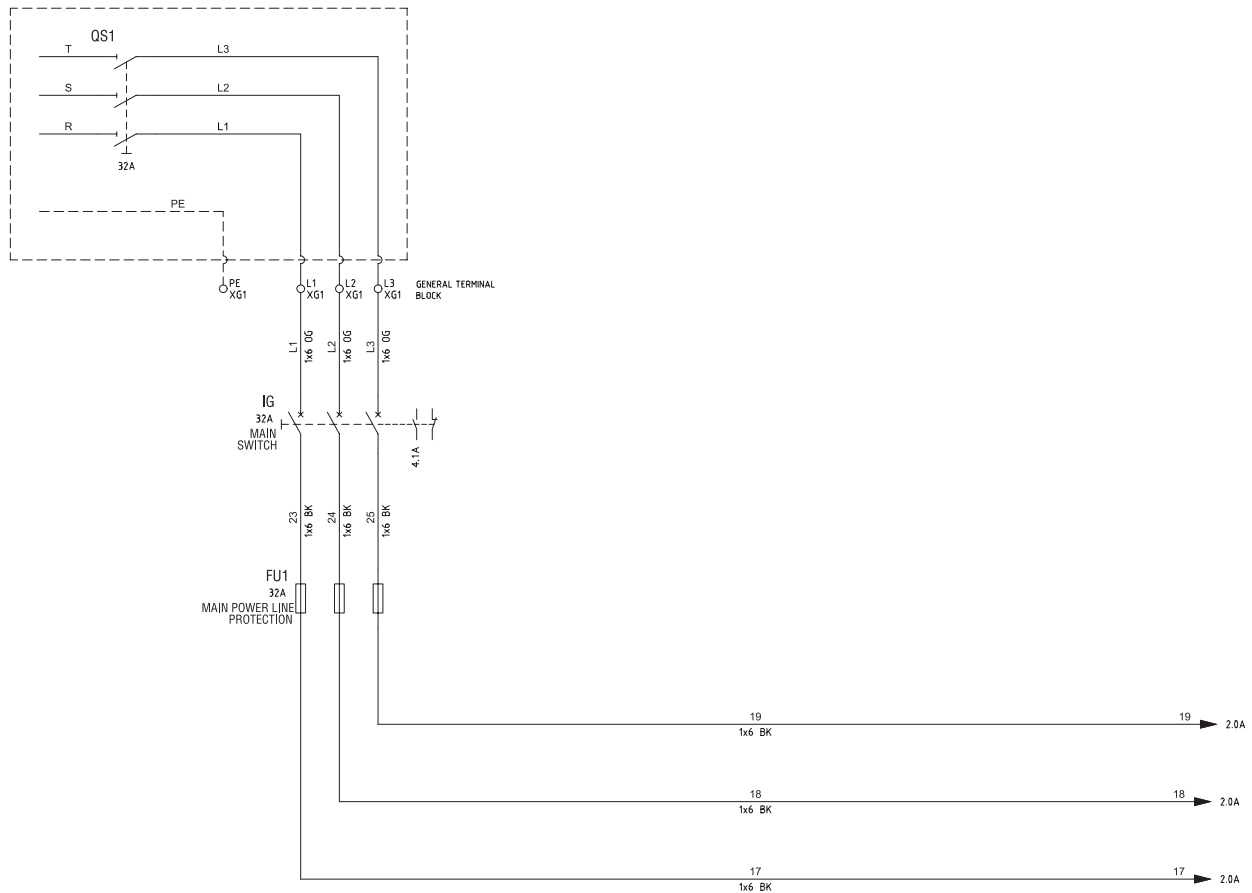

Alimentazione motore

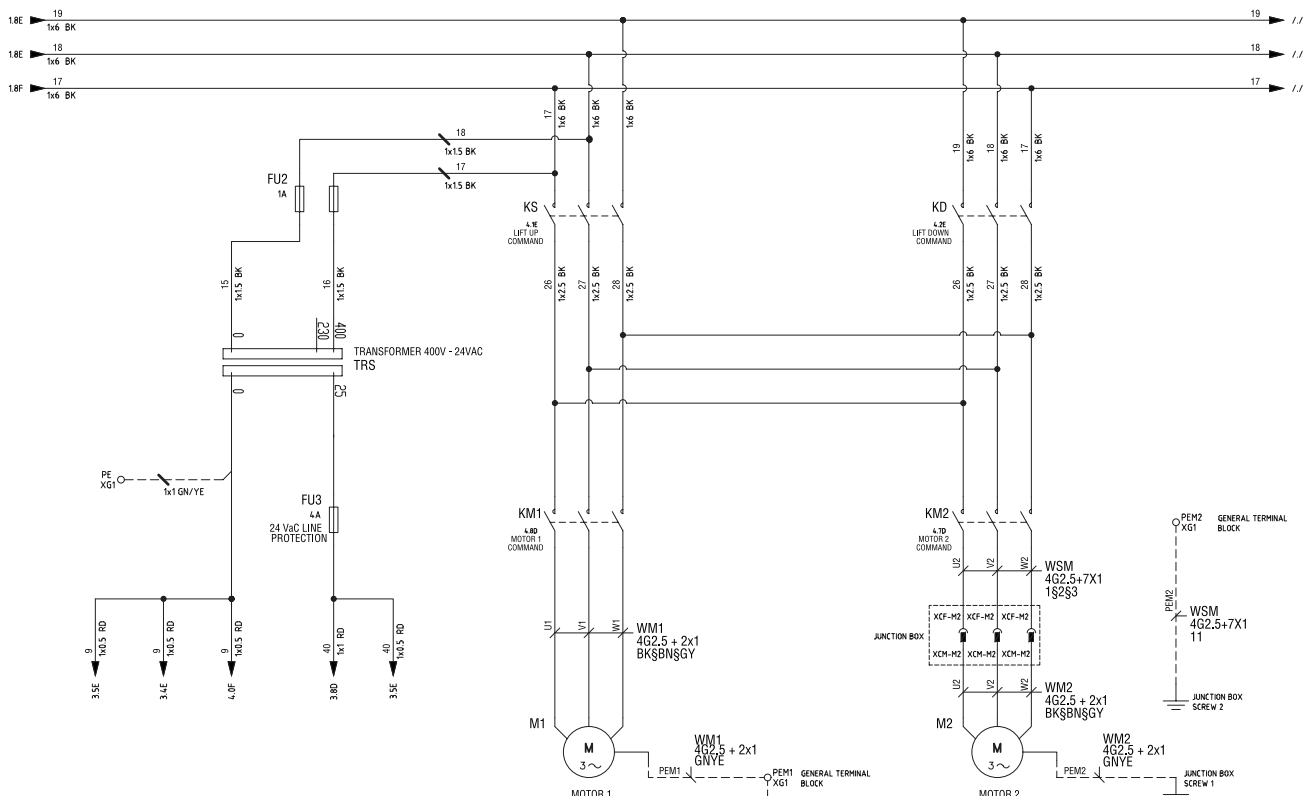

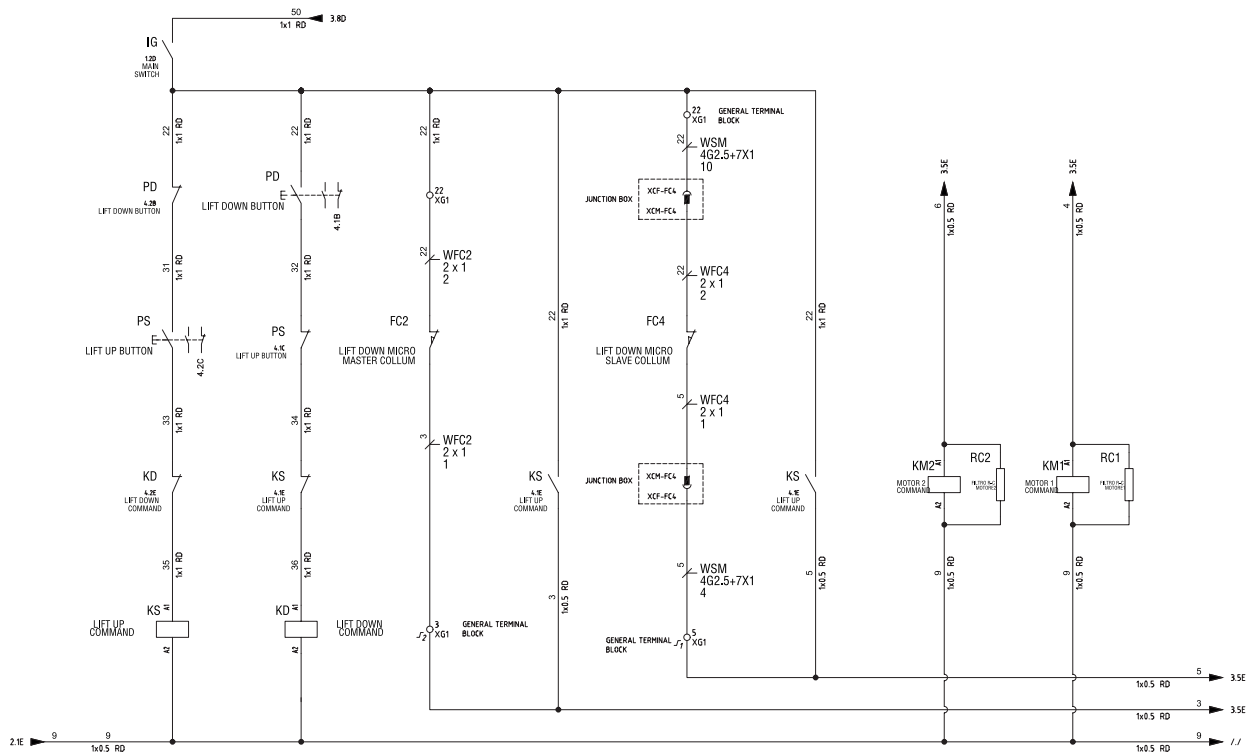
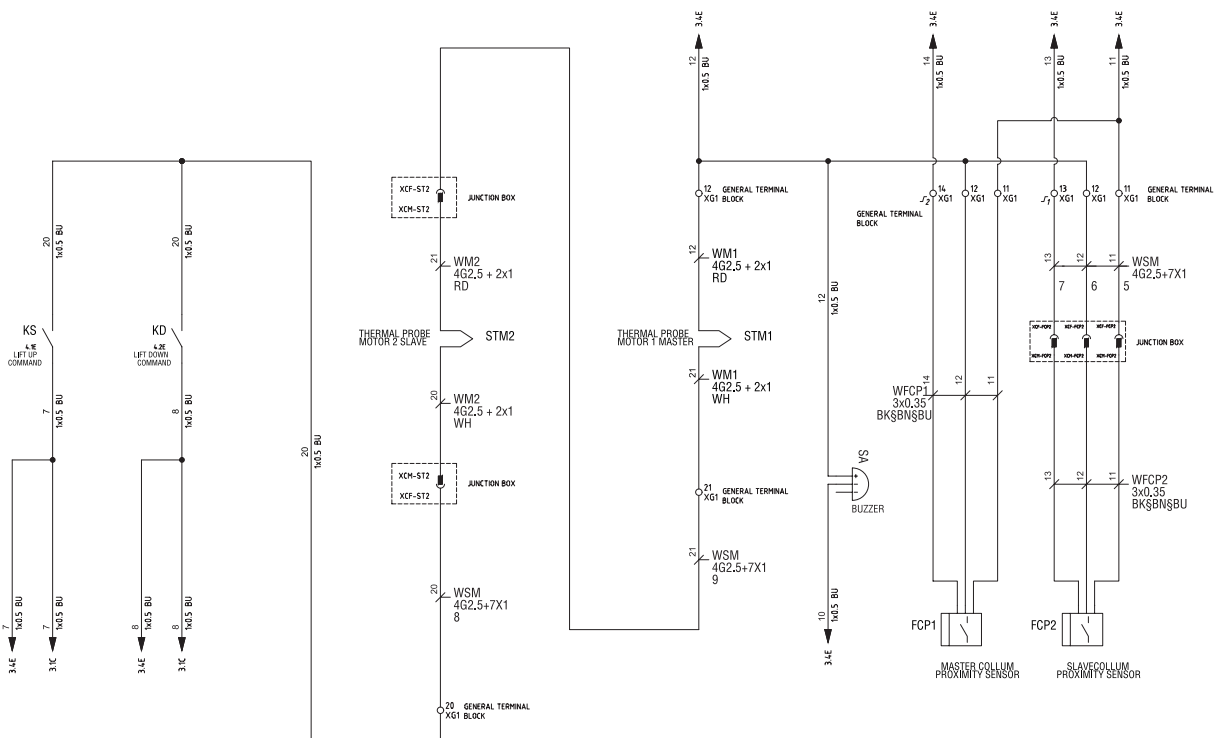
CODICE IMPIANTO ELETTRICO: 047305510
Segnali di comando

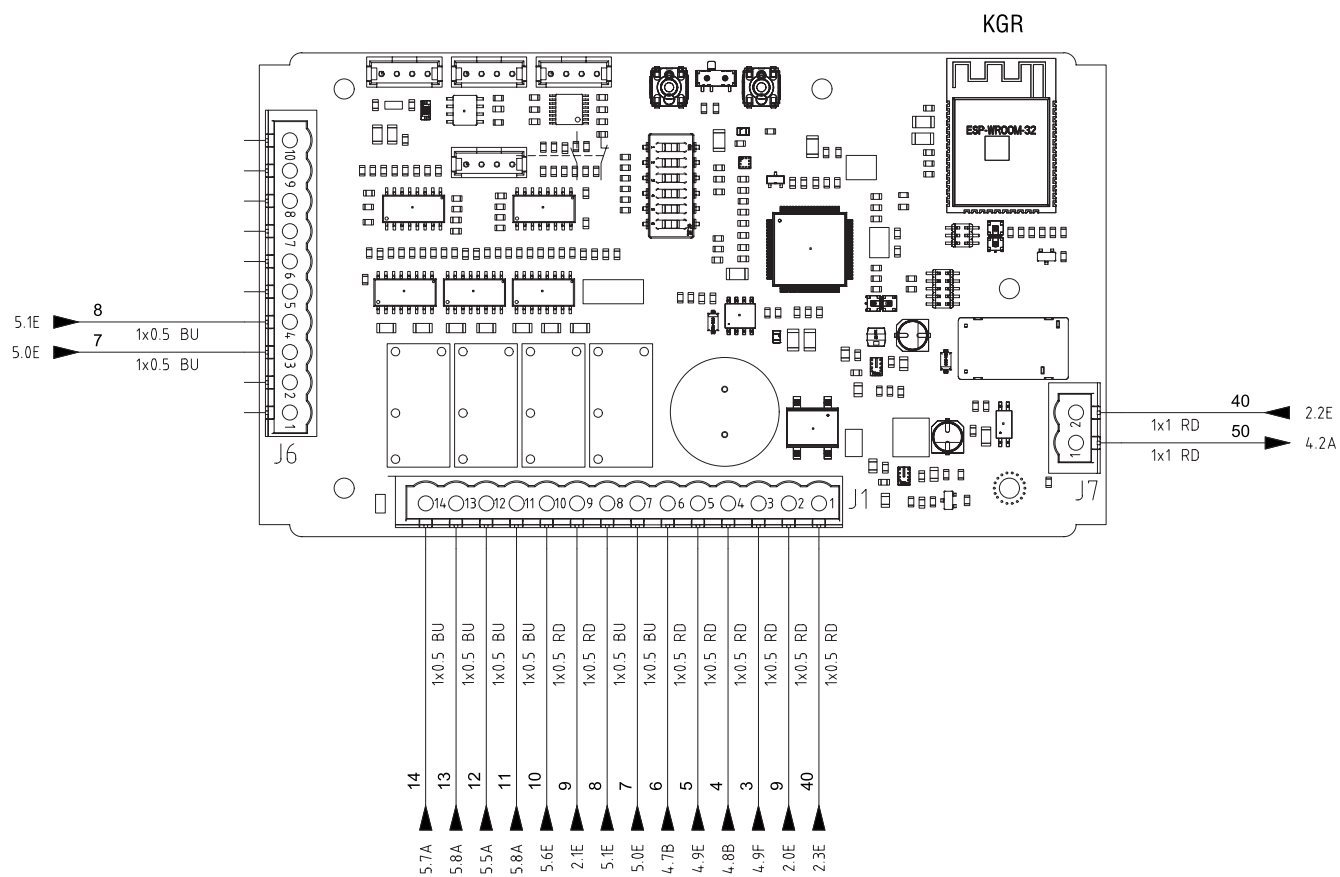
Segnali

CODICE IMPIANTO ELETTRICO: 047305510
Segnali scheda elettronica

CODICE IMPIANTO ELETTRICO: 047305510
Legenda

LISTA CROSS REFERENCE \ CROSS REFERENCE LIST							
Componente	Reference	Dati Tecnici Technical Data		Componente	Reference	Dati Tecnici Technical Data	
		Nome\Item:M1	Quadro\Panel: +BM Fg.\Sh:2			Nome\Item:FU3	Quadro\Panel: +QG Fg.\Sh:2
		Tipo \ Type : Costruttore \ Marke : Descrizione \ Device : Funzione \ Use Type :	Motore asincrono trifase MOTOR 1 COMMAND COLLUM			Tipo \ Type : Costruttore \ Marke : Descrizione \ Device : Funzione \ Use Type :	PORTAFUSIBILE UNIPOLARE 1A 5X20 250V 24 Vac LINE PROTECTION
		Nome\Item:M2	Quadro\Panel: +BM Fg.\Sh:2			Nome\Item:IG	Quadro\Panel: +QG Fg.\Sh:1
		Tipo \ Type : Costruttore \ Marke : Descrizione \ Device : Funzione \ Use Type :	Motore asincrono trifase MOTOR 2 SLAVE COLLUM			Tipo \ Type : Costruttore \ Marke : Descrizione \ Device : Funzione \ Use Type :	INTERRUTTORE GENERALE 4 POLI + AUX, 32A MAIN SWITCH
		Nome\Item:FC2	Quadro\Panel: +BM Fg.\Sh:4			Nome\Item:KD	Quadro\Board: +QG Fg.\Sh:4
		Tipo \ Type : Costruttore \ Marke : Descrizione \ Device : Funzione \ Use Type :	Fine corsa NC LIFT DOWN MICRO MASTER COLLUM			Tipo \ Type : Costruttore \ Marke : Descrizione \ Device : Funzione \ Use Type :	TELERUTTORE COMADO DISCESA LIFT DOWN COMMAND
		Nome\Item:FC4	Quadro\Panel: +BM Fg.\Sh:4			Nome\Item:KM1	Quadro\Panel: +QG Fg.\Sh:4
		Tipo \ Type : Costruttore \ Marke : Descrizione \ Device : Funzione \ Use Type :	Fine corsa NC LIFT DOWN MICRO SLAVE COLLUM			Tipo \ Type : Costruttore \ Marke : Descrizione \ Device : Funzione \ Use Type :	TELERUTTORE COMANDO MOTORE 1 MOTOR 1 COMMAND
		Nome\Item:FU1	Quadro\Panel: +QG Fg.\Sh:1			Nome\Item:KM2	Quadro\Panel: +QG Fg.\Sh:4
		Tipo \ Type : Costruttore \ Marke : Descrizione \ Device : Funzione \ Use Type :	PORTAFUS, TRIPOLARE 10X38 WIMEX 32A 500V MAIN POWER LINE PROTECTION			Tipo \ Type : Costruttore \ Marke : Descrizione \ Device : Funzione \ Use Type :	TELERUTTORE COMANDO MOTORE 2 MOTOR 2 COMMAND
		Nome\Item:FU2	Quadro\Panel: +QG Fg.\Sh:2			Nome\Item:KS	Quadro\Panel: +QG Fg.\Sh:4
		Tipo \ Type : Costruttore \ Marke : Descrizione \ Device : Funzione \ Use Type :	PORTAFUS, BIPOLARE 10X38 WIMEX 1A 500V TRANSFORMER POWER LINE PROTECTION			Tipo \ Type : Costruttore \ Marke : Descrizione \ Device : Funzione \ Use Type :	TELERUTTORE COMANDO SALITA LIFT UP COMMAND

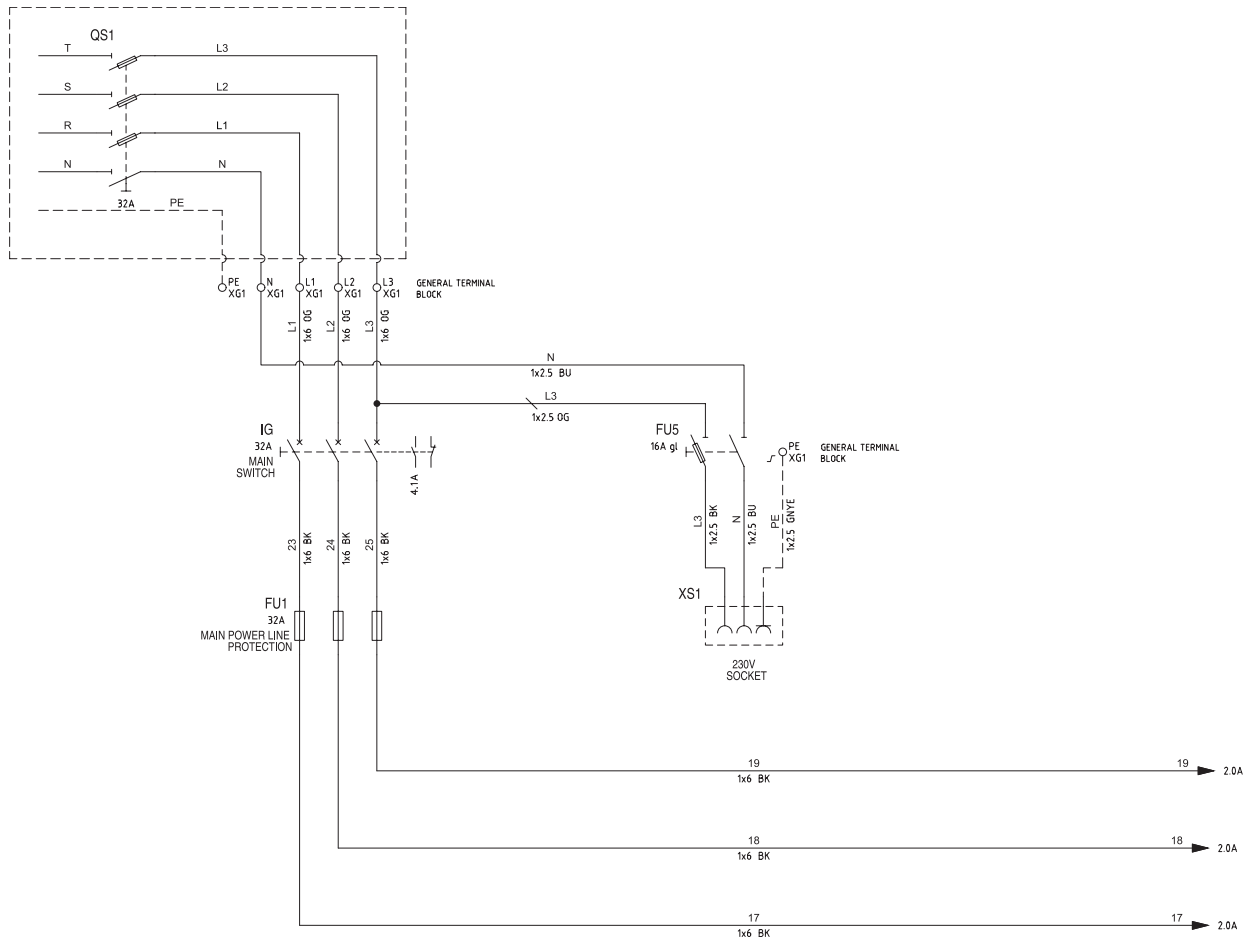
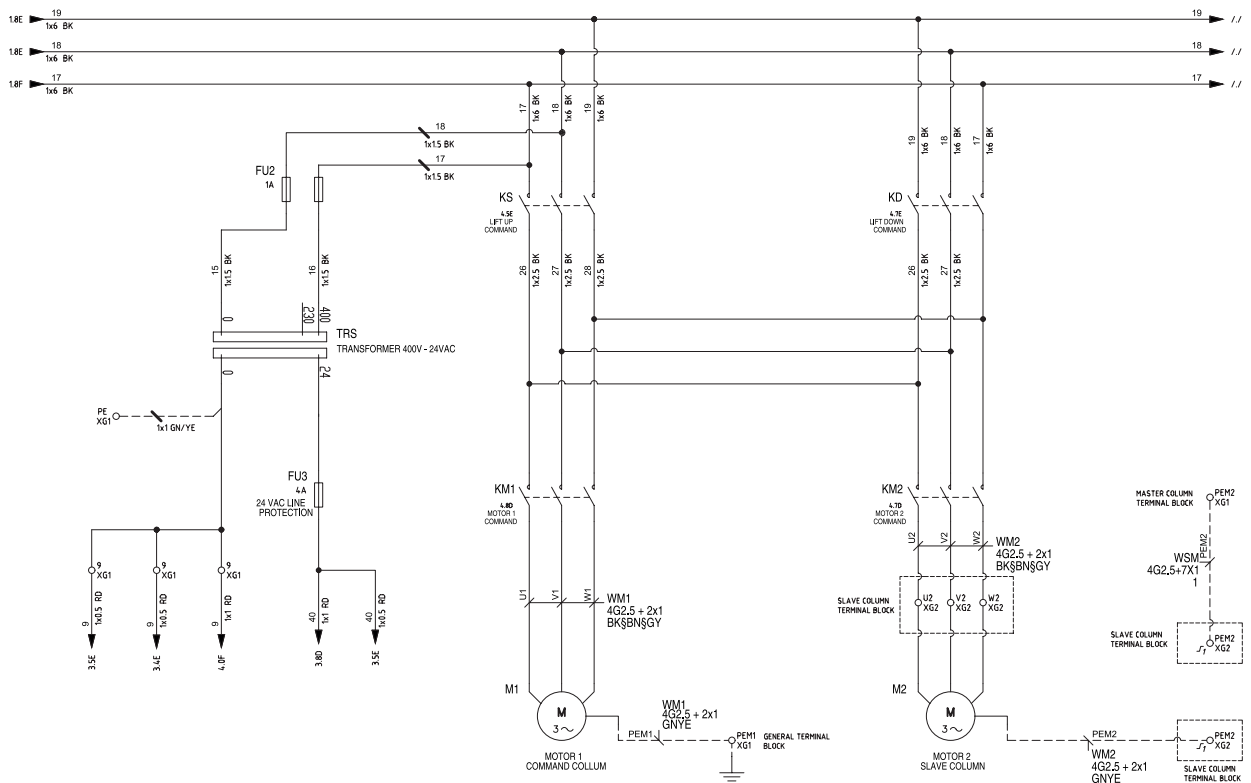
LISTA CROSS REFERENCE \ CROSS REFERENCE LIST							
Componente	Reference	Dati Tecnici Technical Data		Componente	Reference	Dati Tecnici Technical Data	
		Nome\Item:PD	Quadro\Panel: +QG Fg.\Sh:4			Nome\Item:FCP1	Quadro\Panel: +BM Fg.\Sh:5
		Tipo \ Type : Costruttore \ Marke : Descrizione \ Device : Funzione \ Use Type :	PULSANTE DISCESA LIFT DOWN BUTTON			Tipo \ Type : Costruttore \ Marke : Descrizione \ Device : Funzione \ Use Type :	INTERRUTTORE DI PROSSIMITA' PROXIMITY SENSOR
		Nome\Item:PS	Quadro\Panel: +QG Fg.\Sh:4			Nome\Item:FCP2	Quadro\Panel: +BM Fg.\Sh:5
		Tipo \ Type : Costruttore \ Marke : Descrizione \ Device : Funzione \ Use Type :	PULSANTE DISCESA LIFT UP BUTTON			Tipo \ Type : Costruttore \ Marke : Descrizione \ Device : Funzione \ Use Type :	INTERRUTTORE DI PROSSIMITA' PROXIMITY SENSOR
		Nome\Item:QS1	Quadro\Panel: +QG Fg.\Sh:1			Nome\Item:KGR	Quadro\Board: +QG Fg.\Sh:3
		Tipo \ Type : Costruttore \ Marke : Descrizione \ Device : Funzione \ Use Type :	INTERRUTTORE GENERALE CLIENTE 32A CLIENT POWER MAIN SWITCH			Tipo \ Type : Costruttore \ Marke : Descrizione \ Device : Funzione \ Use Type :	SCHEDA ELETTRONICA ELECTRONIC BOARD
		Nome\Item:RC1	Quadro\Panel: +QG Fg.\Sh:4			Nome\Item:STM1	Quadro\Panel: +BM Fg.\Sh:5
		Tipo \ Type : Costruttore \ Marke : Descrizione \ Device : Funzione \ Use Type :	FILTRO ANTIDISTURBI R-C MOTORE1			Tipo \ Type : Costruttore \ Marke : Descrizione \ Device : Funzione \ Use Type :	SONDA TERMICA THERMAL PROBE MOTOR 1 MASTER
		Nome\Item:RC2	Quadro\Panel: +QG Fg.\Sh:4			Nome\Item:STM2	Quadro\Panel: +BM Fg.\Sh:5
		Tipo \ Type : Costruttore \ Marke : Descrizione \ Device : Funzione \ Use Type :	FILTRO ANTIDISTURBI R-C MOTORE2			Tipo \ Type : Costruttore \ Marke : Descrizione \ Device : Funzione \ Use Type :	SONDA TERMICA THERMAL PROBE MOTOR 2 SLAVE
		Nome\Item:SA	Quadro\Panel: +QG Fg.\Sh:5			Nome\Item:TRS	Quadro\Panel: +QG Fg.\Sh:2
		Tipo \ Type : Costruttore \ Marke : Descrizione \ Device : Funzione \ Use Type :	AVVISATORE ACUSTICO BUZZER			Tipo \ Type : Costruttore \ Marke : Descrizione \ Device : Funzione \ Use Type :	TRASFORMATORE 100 V/A TRANSFORMER 400V - 24VAC

CODICE IMPIANTO ELETTRICO: 047305530
Alimentazione elettrica

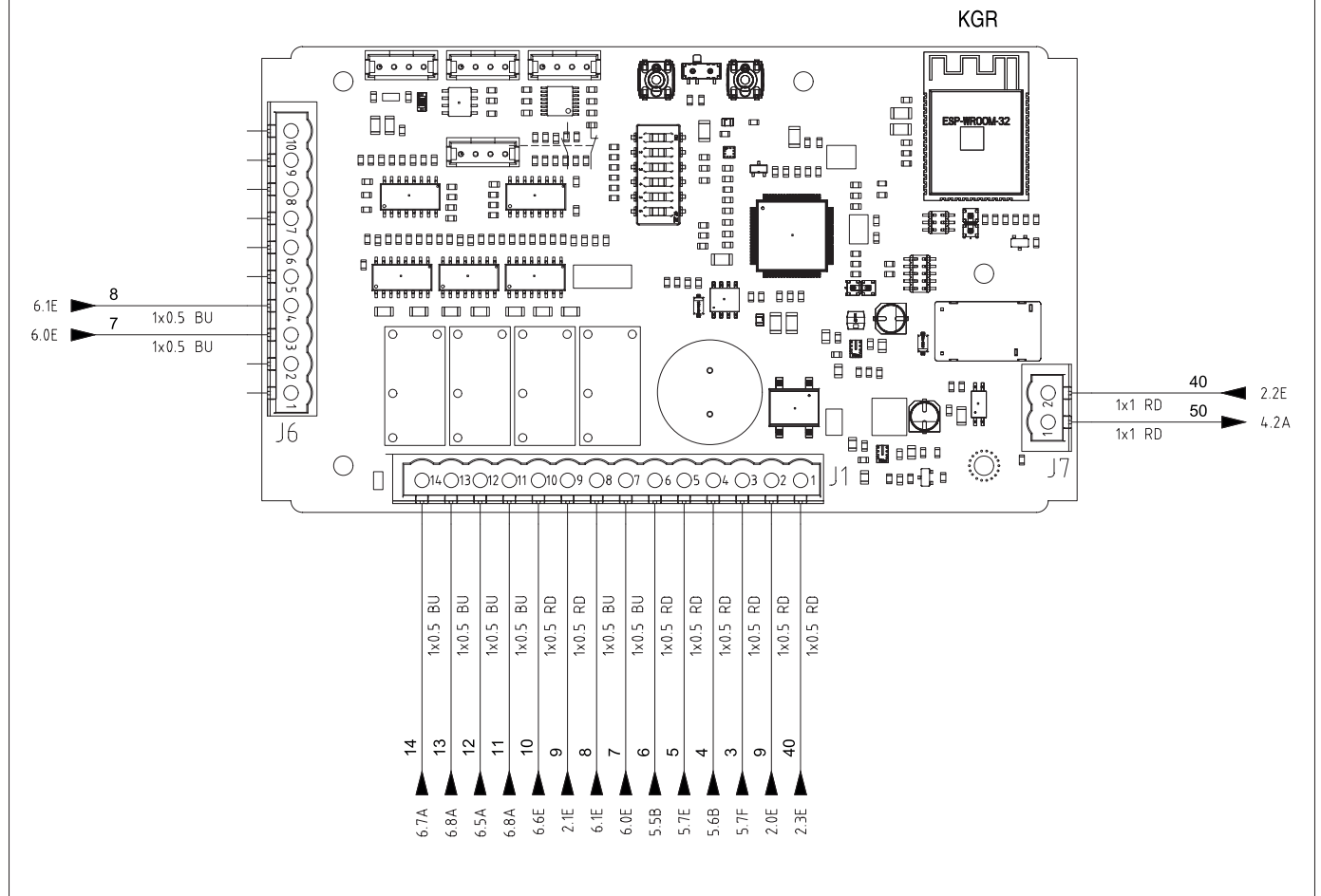
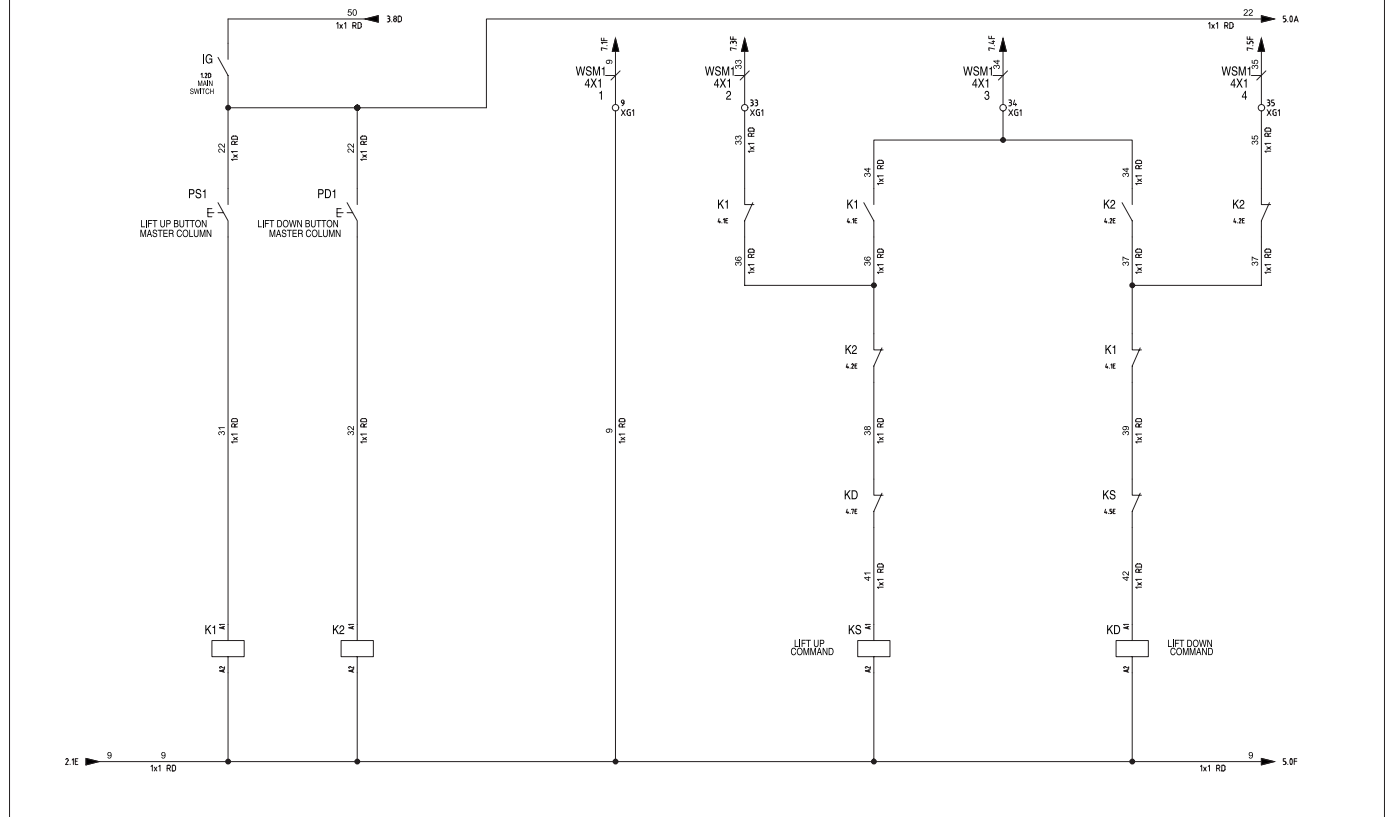
Alimentazione motore

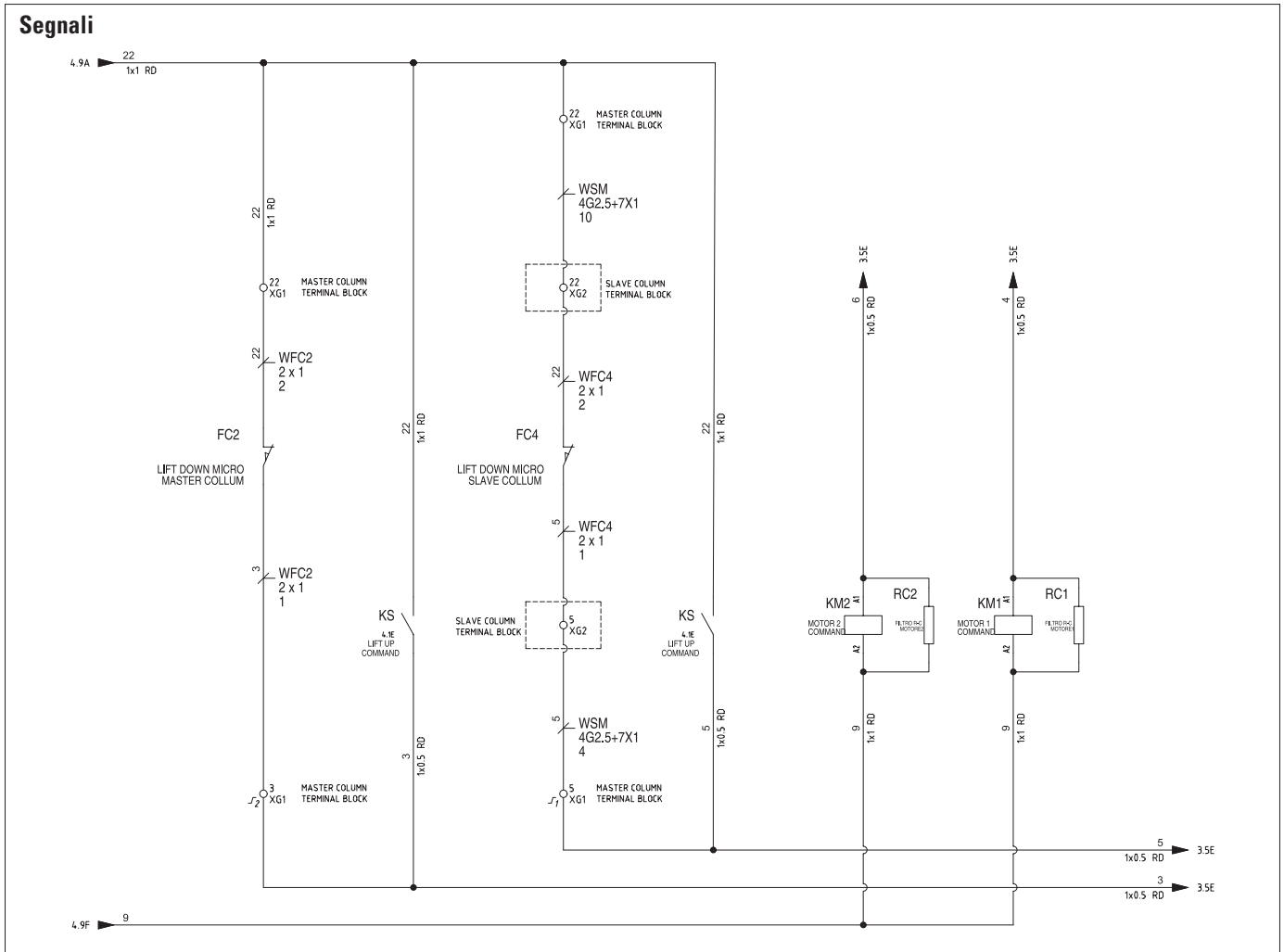
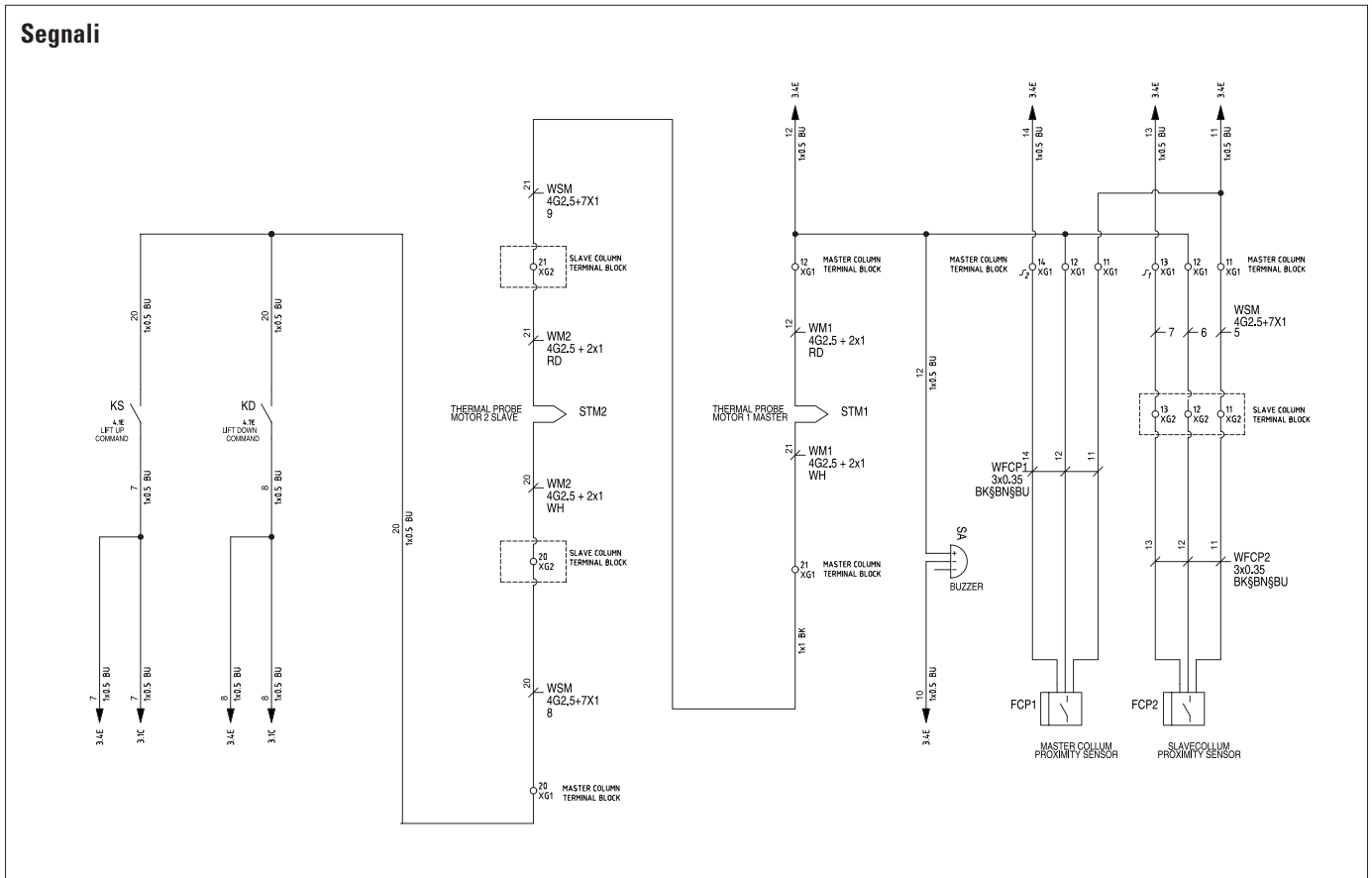
CODICE IMPIANTO ELETTRICO: 047305530
Segnali scheda elettronica

Segnali di comando

CODICE IMPIANTO ELETTRICO: 047305530
Segnali

Segnali

CODICE IMPIANTO ELETTRICO: 047305530
Legenda

LISTA CROSS REFERENCE \ CROSS REFERENCE LIST							
Componente	Reference	Dati Tecnici	Technical Data	Componente	Reference	Dati Tecnici	Technical Data
		Nome\Item:M1	Quadro\Panel: +BM Fg.\Sh.:2			Nome\Item:FU3	Quadro\Panel: +QG Fg.\Sh.:2
		Tipo \ Type : Costruttore \ Marke: Descrizione \ Device : Motore asincrono trifase Funzione \ Use Type : MOTOR 1 COMMAND COLLUM				Tipo \ Type : Costruttore \ Marke: Descrizione \ Device : PORTAFUSIBILE UNIPOLARE 1A 5X20 250V Funzione \ Use Type : 24 VaC LINE PROTECTION	
		Nome\Item:M2	Quadro\Panel: +BM Fg.\Sh.:2			Nome\Item:IG	Quadro\Panel: +QG Fg.\Sh.:1
		Tipo \ Type : Costruttore \ Marke: Descrizione \ Device : Motore asincrono trifase Funzione \ Use Type : SLAVE COLUMN				Tipo \ Type : Costruttore \ Marke: Descrizione \ Device : INTERRUTTORE GENERALE 4 POLI + AUX. 32A Funzione \ Use Type : MAIN SWITCH	
		Nome\Item:FC2	Quadro\Panel: +BM Fg.\Sh.:4			Nome\Item:KD	Quadro\Board: +QG Fg.\Sh.:4
		Tipo \ Type : Costruttore \ Marke: Descrizione \ Device : Fine corsa NC Funzione \ Use Type : LIFT DOWN MICRO MASTER COLLUM				Tipo \ Type : Costruttore \ Marke: Descrizione \ Device : TELERUTTORE COMADO DISCESA Funzione \ Use Type : LIFT DOWN COMMAND	
		Nome\Item:FC4	Quadro\Panel: +BM Fg.\Sh.:4			Nome\Item:KM1	Quadro\Panel: +QG Fg.\Sh.:4
		Tipo \ Type : Costruttore \ Marke: Descrizione \ Device : Fine corsa NC Funzione \ Use Type : LIFT DOWN MICRO SLAVE COLLUM				Tipo \ Type : Costruttore \ Marke: Descrizione \ Device : TELERUTTORE COMANDO MOTORE 1 Funzione \ Use Type : MOTOR 1 COMMAND	
		Nome\Item:FU1	Quadro\Panel: +QG Fg.\Sh.:1			Nome\Item:KM2	Quadro\Panel: +QG Fg.\Sh.:4
		Tipo \ Type : Costruttore \ Marke: Descrizione \ Device : PORTAFUS. TRIPOLARE 10X38 WIMEX 32A 500V Funzione \ Use Type : MAIN POWER LINE PROTECTION				Tipo \ Type : Costruttore \ Marke: Descrizione \ Device : TELERUTTORE COMANDO MOTORE 2 Funzione \ Use Type : MOTOR 2 COMMAND	
		Nome\Item:FU2	Quadro\Panel: +QG Fg.\Sh.:2			Nome\Item:KS	Quadro\Panel: +QG Fg.\Sh.:4
		Tipo \ Type : Costruttore \ Marke: Descrizione \ Device : PORTAFUS. BIPOLARE 10X38 WIMEX 1A 500V Funzione \ Use Type : TRANSFORMER POWER LINE PROTECTION				Tipo \ Type : Costruttore \ Marke: Descrizione \ Device : TELERUTTORE COMANDO SALITA Funzione \ Use Type : LIFT UP COMMAND	

LISTA CROSS REFERENCE \ CROSS REFERENCE LIST							
Componente	Reference	Dati Tecnici	Technical Data	Componente	Reference	Dati Tecnici	Technical Data
		Nome\Item:PD	Quadro\Panel: +QG Fg.\Sh.:4			Nome\Item:FCP1	Quadro\Panel: +BM Fg.\Sh.:5
		Tipo \ Type : Costruttore \ Marke: Descrizione \ Device : PULSANTE DISCESA Funzione \ Use Type : LIFT DOWN BUTTON				Tipo \ Type : Costruttore \ Marke: Descrizione \ Device : INTERRUTTORE DI PROSSIMITA' Funzione \ Use Type : PROXIMITY SENSOR	
		Nome\Item:PS	Quadro\Panel: +QG Fg.\Sh.:4			Nome\Item:FCP2	Quadro\Panel: +BM Fg.\Sh.:5
		Tipo \ Type : Costruttore \ Marke: Descrizione \ Device : PULSANTE DISCESA Funzione \ Use Type : LIFT UP BUTTON				Tipo \ Type : Costruttore \ Marke: Descrizione \ Device : INTERRUTTORE DI PROSSIMITA' Funzione \ Use Type : PROXIMITY SENSOR	
		Nome\Item:QS1	Quadro\Panel: +QG Fg.\Sh.:1			Nome\Item:KGR	Quadro\Board: +QG Fg.\Sh.:3
		Tipo \ Type : Costruttore \ Marke: Descrizione \ Device : INTERRUTTORE GENERALE CLIENTE 32A Funzione \ Use Type : CLIENT POWER MAIN SWITCH				Tipo \ Type : Costruttore \ Marke: Descrizione \ Device : SCHEDA ELETTRONICA Funzione \ Use Type : ELECTRONIC BOARD	
		Nome\Item:RC1	Quadro\Panel: +QG Fg.\Sh.:4			Nome\Item:STM1	Quadro\Panel: +BM Fg.\Sh.:5
		Tipo \ Type : Costruttore \ Marke: Descrizione \ Device : FILTRO ANTIDISTURBI R-C Funzione \ Use Type : MOTORE1				Tipo \ Type : Costruttore \ Marke: Descrizione \ Device : SONDA TERMICA Funzione \ Use Type : THERMAL PROBE MOTOR 1 MASTER	
		Nome\Item:RC2	Quadro\Panel: +QG Fg.\Sh.:4			Nome\Item:STM2	Quadro\Panel: +BM Fg.\Sh.:5
		Tipo \ Type : Costruttore \ Marke: Descrizione \ Device : FILTRO ANTIDISTURBI R-C Funzione \ Use Type : MOTORE2				Tipo \ Type : Costruttore \ Marke: Descrizione \ Device : SONDA TERMICA Funzione \ Use Type : THERMAL PROBE MOTOR 2 SLAVE	
		Nome\Item:SA	Quadro\Panel: +QG Fg.\Sh.:5			Nome\Item:TRS	Quadro\Panel: +QG Fg.\Sh.:2
		Tipo \ Type : Costruttore \ Marke: Descrizione \ Device : AVVISATORE ACUSTICO Funzione \ Use Type : BUZZER				Tipo \ Type : Costruttore \ Marke: Descrizione \ Device : TRASFORMATORE 100 V/A Funzione \ Use Type : TRANSFORMER 400V - 24VAC	
		Nome\Item: FU5	Quadro\Panel: +QG Fg.\Sh.:1			Nome\Item:	Quadro\Panel: Fg.\Sh.:
		Tipo \ Type : Costruttore \ Marke: Descrizione \ Device : Funzione \ Use Type :PROTEZIONE LINA 230V PRESA				Tipo \ Type : Costruttore \ Marke: Descrizione \ Device : Funzione \ Use Type :	
		Nome\Item: XS1	Quadro\Panel: +QG Fg.\Sh.:1			Nome\Item:	Quadro\Panel: Fg.\Sh.:
		Tipo \ Type : Costruttore \ Marke: Descrizione \ Device : PRESA 230V Funzione \ Use Type :				Tipo \ Type : Costruttore \ Marke: Descrizione \ Device : Funzione \ Use Type :	

CAP. 4 NORME GENERALI DI SICUREZZA

4.1 INDICAZIONI DEI RISCHI RESIDUI

Il nostro sollevatore è stato realizzato applicando severe norme per la rispondenza ai requisiti richiamati dalle direttive pertinenti. L'analisi dei rischi è stata effettuata accuratamente ed i pericoli sono stati, per quanto possibile, eliminati. Eventuali rischi residui sono evidenziati nel presente manuale e sulla macchina mediante pittogrammi di attenzione.

4.2 TARGHETTE E/O ADESIVI DI SICUREZZA

Nel sollevatore sono presenti targhette e adesivi necessari all'identificazione della macchina, alla portata, alle istruzioni e all'impianto elettrico.

Nel caso che questi pittogrammi si danneggino è necessario sostituirli richiedendoli alla ROTARY.

4.3 ADDESTRAMENTO DEL PERSONALE PREPOSTO

L'uso dell'apparecchiatura è consentito solo a personale appositamente addestrato ed autorizzato. Affinchè la gestione della macchina sia ottimale e si possano effettuare le operazioni con efficienza è necessario che il personale addetto venga addestrato in modo corretto per apprendere le necessarie informazioni al fine di raggiungere un modo operativo in linea con le indicazioni fornite dal costruttore.

Per qualsiasi dubbio relativo all'uso e alla manutenzione della macchina, consultare il manuale di istruzioni ed eventualmente i centri di assistenza autorizzati o l'assistenza tecnica ROTARY.

4.4 ATTITUDINE ALL'IMPIEGO

Questo prodotto è stato costruito conformemente alla Direttiva Europea 2006/42/CE. In virtù dell'articolo 4.1.2.3 (Allegato 1) della suddetta Direttiva, i coefficienti adottati per le prove sono i seguenti:

1.10 per la prova Dinamica

1.25 per la prova Statica

Queste prove devono essere fatte da personale specializzato.

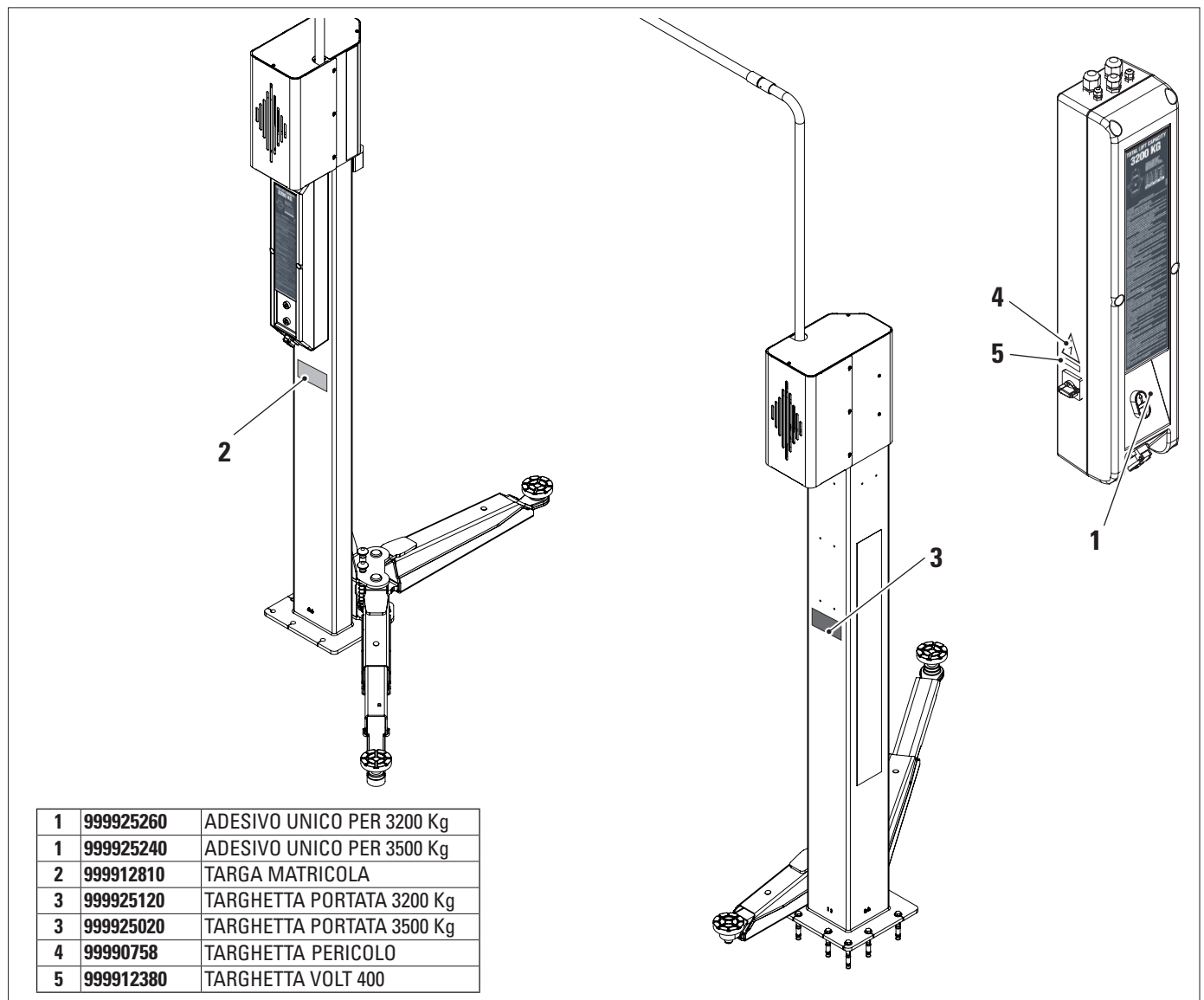

CAP. 5 REQUISITI PER L'INSTALLAZIONE



5.1 REQUISITI MINIMI RICHIESTI PER LUOGO DI INSTALLAZIONE

Accertarsi che il luogo ove poi verrà installata la macchina sia conforme alle seguenti caratteristiche:

- l'uso del sollevatore è consentito esclusivamente all'interno di locali chiusi, ove non sussistano pericoli di esplosione o incendio.
- il sollevatore non è idoneo ad un utilizzo che preveda il lavaggio dei veicoli.
- illuminazione sufficiente (ma luogo non sottoposto ad abbagliamenti o luci intense). Riferimento norma UNI 10380;
- luogo non esposto alle intemperie;
- luogo in cui sia previsto adeguato ricambio aria;
- ambiente privo di inquinanti;
- livello di rumorosità inferiore alle prescrizioni normative vigenti a I 70 dB (A);
- temperatura del locale: min. 5° - max 55°;
- il posto di lavoro non deve essere esposto a movimenti pericolosi dovuti ad altre macchine in funzionamento;
- il locale ove la macchina viene installata non deve essere adibito allo stoccaggio di materiali esplosivi, corrosivi e/o tossici;
- la distanza delle colonne dalle pareti o da qualunque attrezzatura fissa deve essere almeno di 50 cm.
- scegliere il layout di installazione considerando che dalla posizione di comando l'operatore deve essere in grado di visualizzare tutto l'apparecchio e l'area circostante. Egli deve impedire, in tale area, la presenza di persone non autorizzate e di oggetti che potrebbero causare fonte di pericolo.

Tutte le operazioni di installazione relative ai collegamenti ad alimentazioni esterne (elettriche in particolar modo) devono essere eseguite da personale professionalmente qualificato.

L'installazione deve essere eseguita da personale autorizzato seguendo le istruzioni particolari eventualmente presenti in questo libretto; in caso di dubbi consultare i centri di assistenza autorizzati o l'assistenza tecnica ROTARY

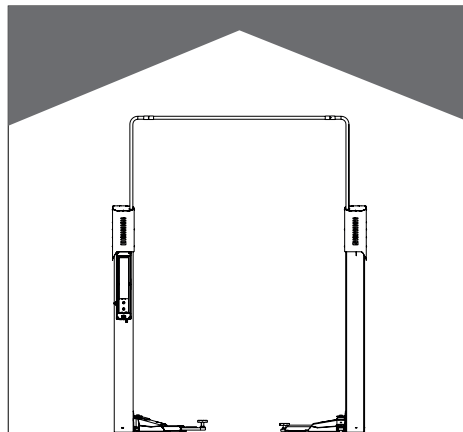

SI

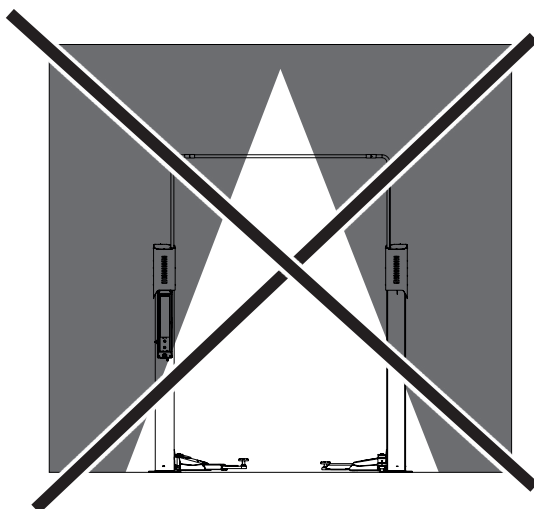

NO

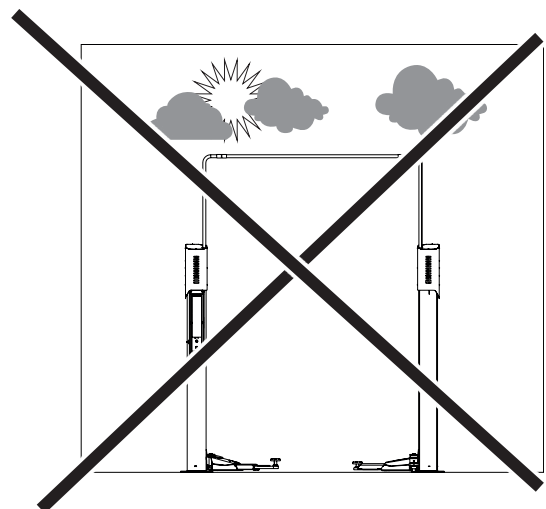

NO

5.2 REQUISITI DELLA PAVIMENTAZIONE

Il sollevatore deve essere installato su pavimento piano ed orizzontale in grado di reggere i **CARICHI TRASMESSI AL PIANO DI APPOGGIO** indicati in tabella (fig. B). Le caratteristiche minime devono essere:

- a) Qualità calcestruzzo: min C25/30
- b) Spessore minimo pavimentazione: 160mm (al netto di eventuali pavimentazioni e relativi massetti) (*)

Si consiglia di consultare un tecnico qualificato per l'idoneità all'installazione

(*) Lo spessore minimo è influenzato dal tipo di tassello impiegato

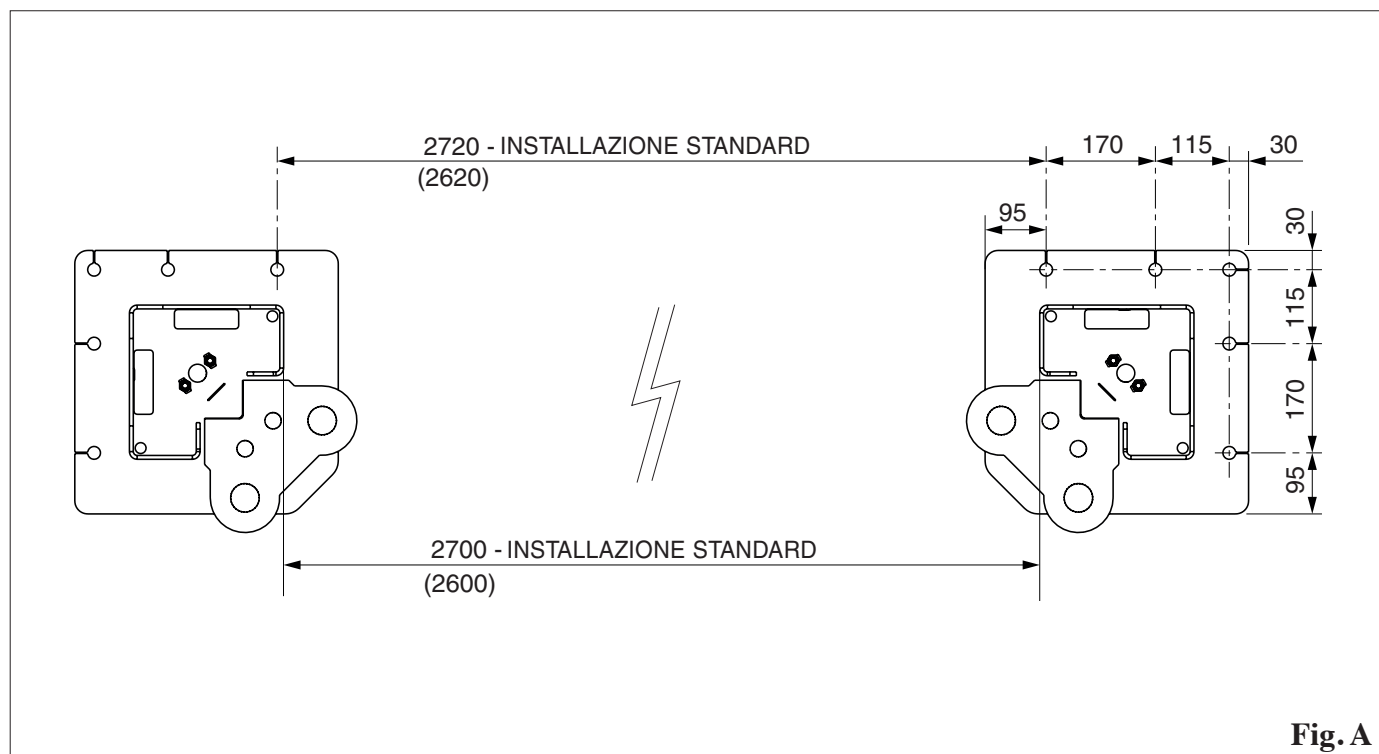
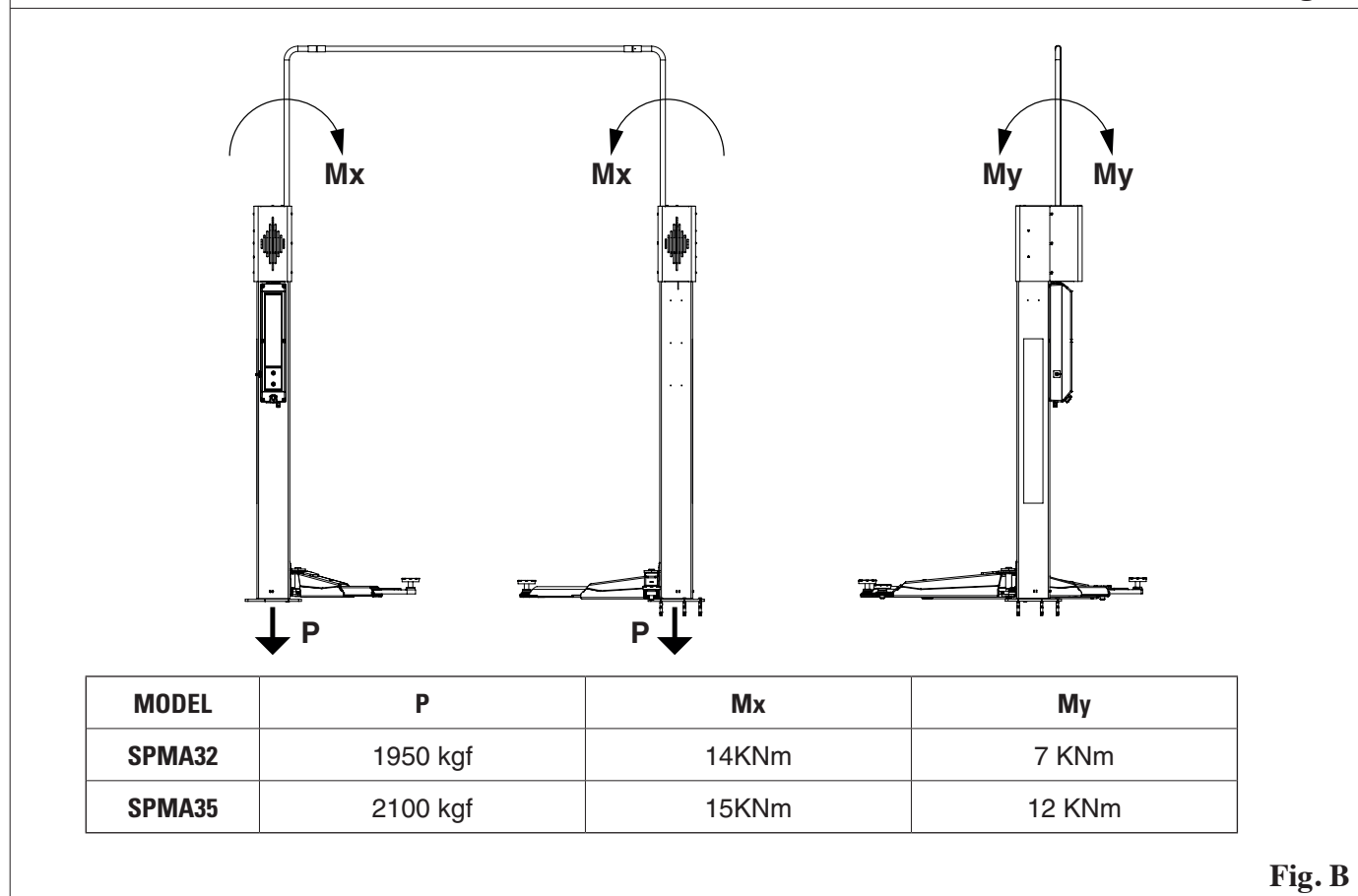
Fig. A

Fig. B

CAP. 6 MOVIMENTAZIONE E PREINSTALLAZIONE

- Il sollevatore viene spedito solitamente come illustrato in figura **A**.
- La confezione (1) contiene gli accessori e le minuterie per il completamento dell'assemblaggio.
- Le operazioni di sollevamento devono essere eseguite come da figura **B**.
- Sollevare con cautela e trasportare i vari gruppi nel luogo ove avverrà il disimballo.

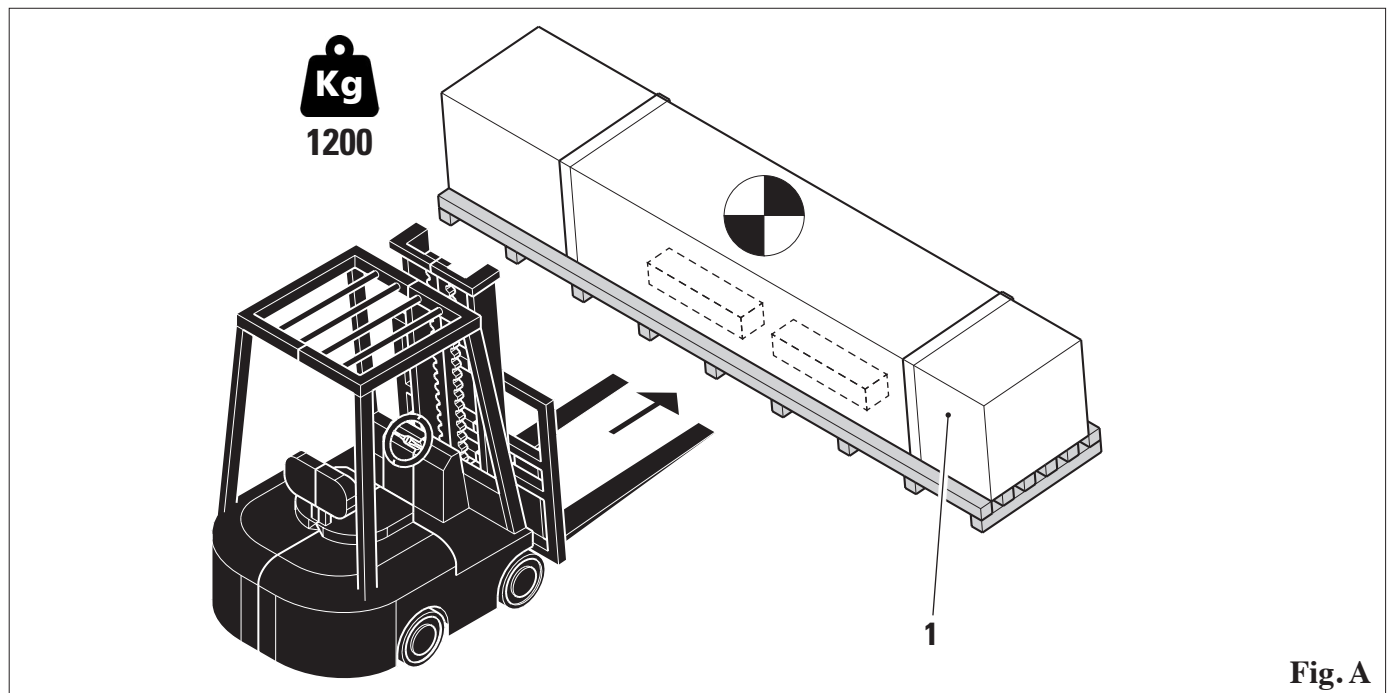
- Per lo spostamento della macchina nel punto prescelto per l'installazione (o per una successiva ridisposizione) assicurarsi di:
 - sollevare con cautela, adoperando adeguati mezzi di sostegno del carico, in perfetta efficienza, utilizzando gli appositi punti di aggancio come indicato in figura **B**.
 - evitare sobbalzi e strattoni improvvisi, prestare attenzione a dislivelli, cunette, ecc. ...;
 - prestare la massima attenzione alle parti sporgenti: ostacoli, passaggi difficili, ecc. ...;
 - indossare adeguati indumenti e protezioni individuali;
 - dopo aver rimosso le varie parti dell'imballo, riporle in appositi luoghi di raccolta inaccessibili a bambini e animali per poi essere smaltite;
 - verificare al momento dell'arrivo l'integrità dell'imballo e a disimballo avvenuto che non vi siano danneggiamenti.

Fig. A

Procedura di movimentazione:

Montare il golfare (2) (opzionale) sulla vite (3).

Posizionare la cinghia (4) nel golfare e sul sostegno del carico come da figura.

Sollevare con cautela la colonna fino a portarla in posizione verticale.

Togliere la cinghia dal golfare.

Smontare il golfare (2).

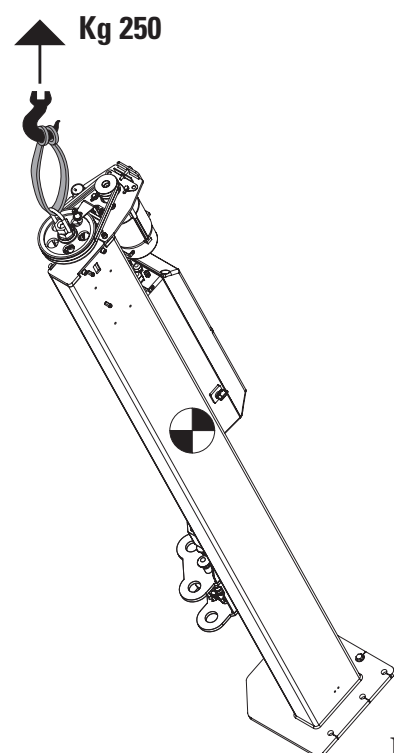
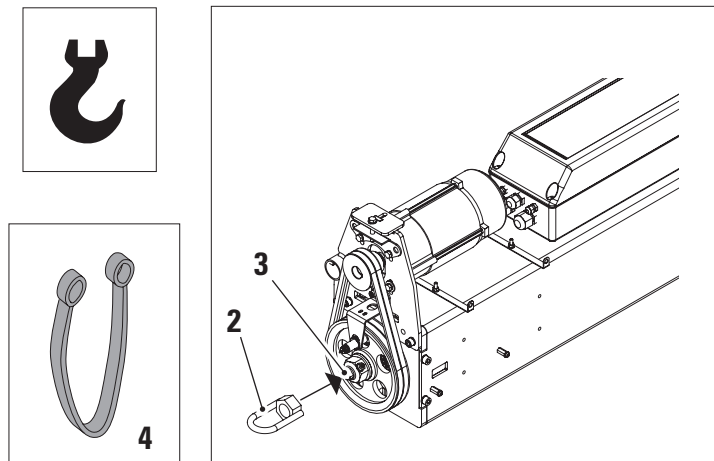
Fig. B

CAP. 7 INSTALLAZIONE



7.1 TASSELLI

Il sollevatore deve essere fissato alla pavimentazione tramite tasselli ad espansione meccanici tipo HILTI HSL-3 M12 o similari oppure tramite ancoraggi chimici in fiale HILTI HVU-M12 o similari (con barra filettata M12 in acciaio classe 5.8 o superiore).

In relazione alla profondità del calcestruzzo rispetto al piano del pavimento, I TASSELLI DEBONO AVERE LUNGHEZZA IDONEA A RAGGIUNGERE IL PAVIMENTO PORTANTE. (vedi fig. A-B).

7.2 CALCESTRUZZO

Per calcestruzzo di classe inferiore si consiglia di impiegare idonei tasselli chimici.

N.B. si consiglia di poggiare la base delle colonne direttamente sul calcestruzzo anche in presenza di pavimentazione riportata. Tuttavia se questa è di buona qualità è possibile fissare le colonne direttamente sul pavimento, utilizzando ancoraggi di lunghezza adeguata.

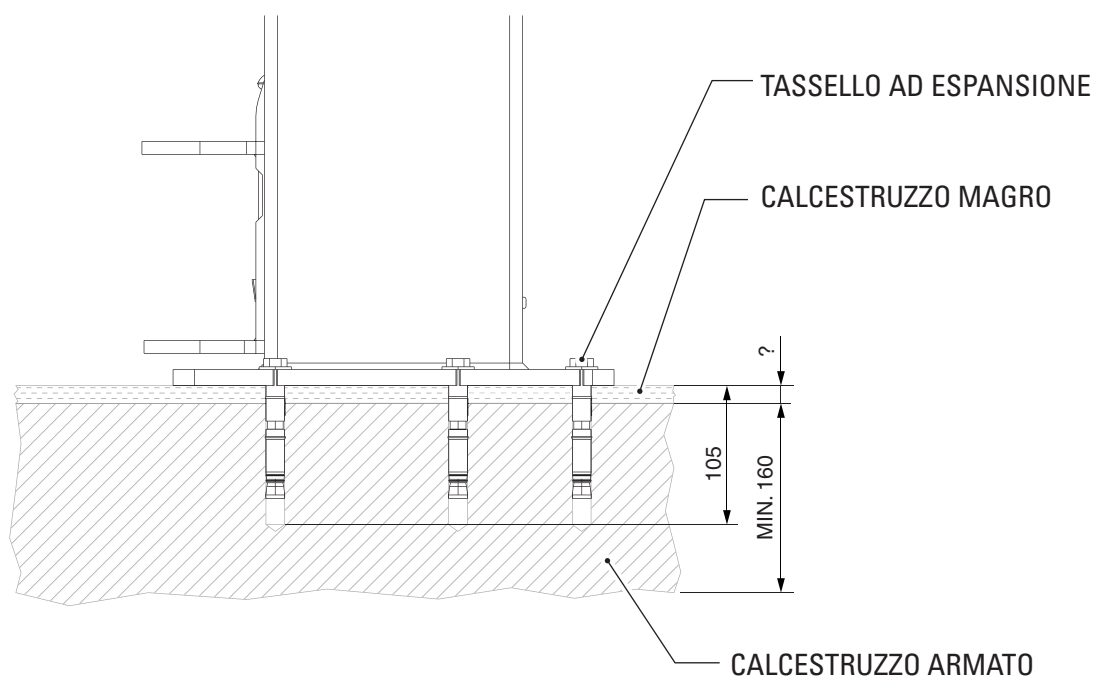

Fig. A

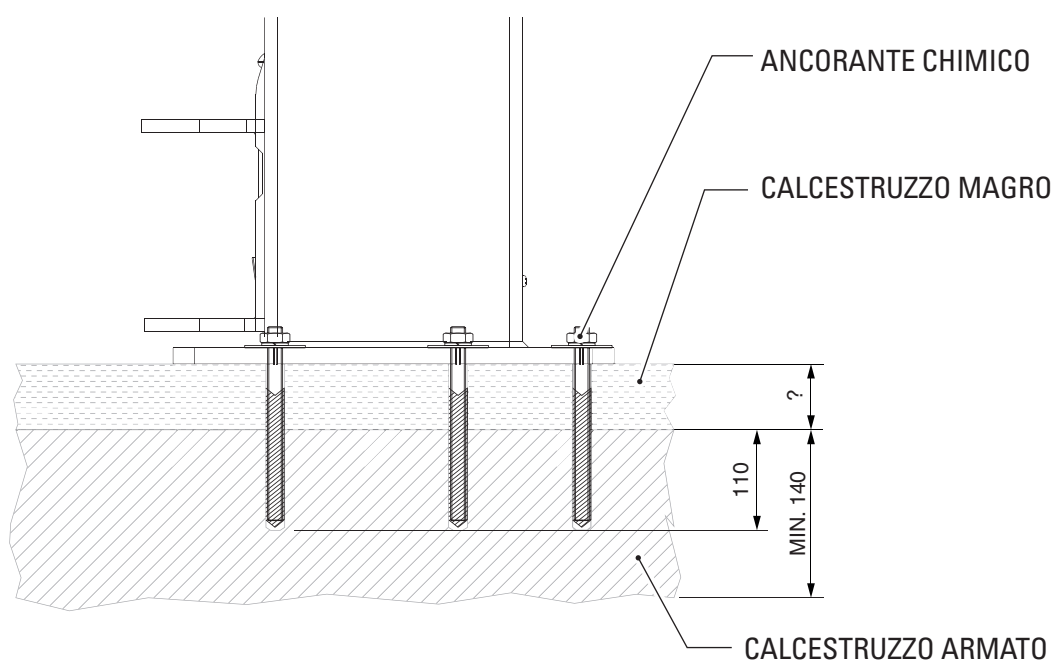

Fig. B

7.3 ISTRUZIONI PER L'INSTALLAZIONE



La posa dei tasselli deve essere effettuata utilizzando le basi come dime di foratura.

NB: Per le modalità di posa e applicazione dei tasselli, consultare le specifiche tecniche fornite dal costruttore dei tasselli.

Procedura di installazione:

- posizionare in verticale una colonna;
- spessorare eventuali luci presenti sotto la piastra di base (fig.B)
- tracciare i fori e forare seguendo le procedure indicate dal costruttore dei tasselli;
- fissare il tassello in posizione;
- portare in verticale l'altra colonna e posizionarla alla distanza indicata nel **cap. 5.2**;
- procedere con le fasi di foratura e fissaggio tasselli descritte precedentemente per entrambe le colonne.

⚠ ! Verificare l'ancoraggio dopo una decina di corse a pieno carico controllando la coppia di serraggio dei tasselli. Questo controllo deve essere eseguito ogni 3 mesi.

- Montare il tubolare passacavo (1) sulle piastre di supporto motore.
- Passare il cavo elettrico (2) all'interno del tubolare (1).
- Eseguire i collegamenti alle scatole di derivazione (fig.C).

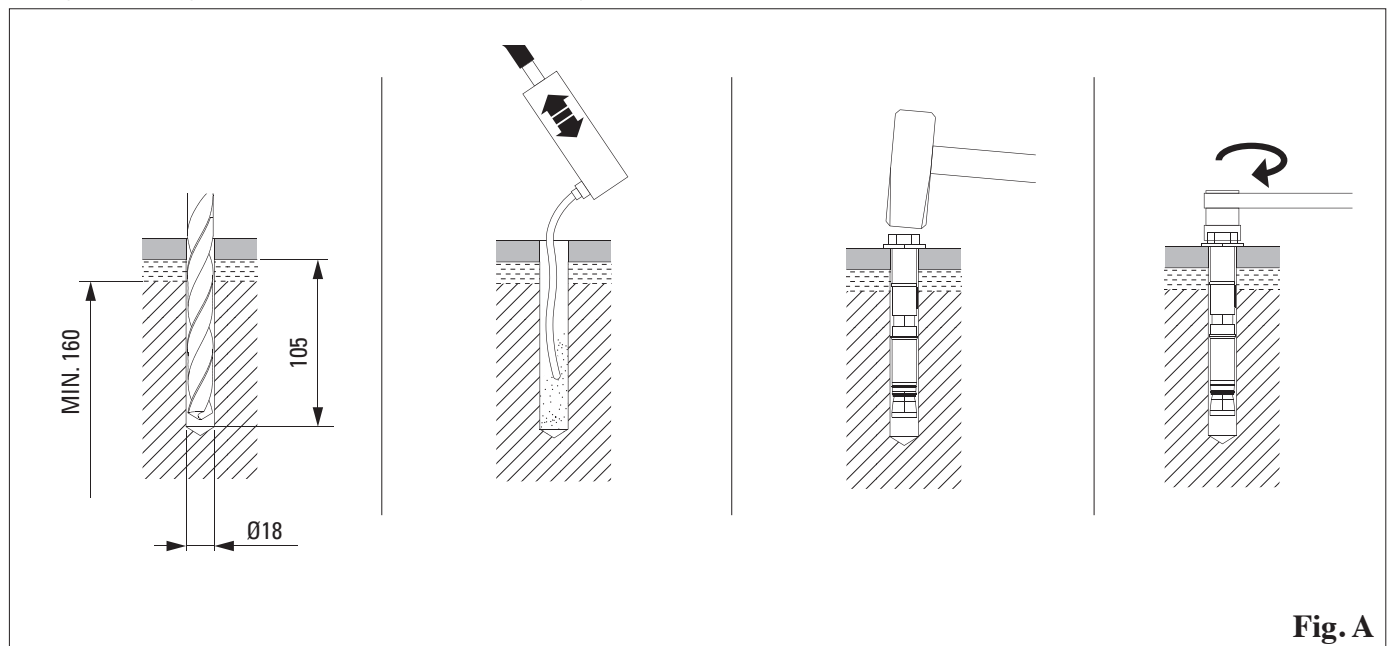

Fig. A

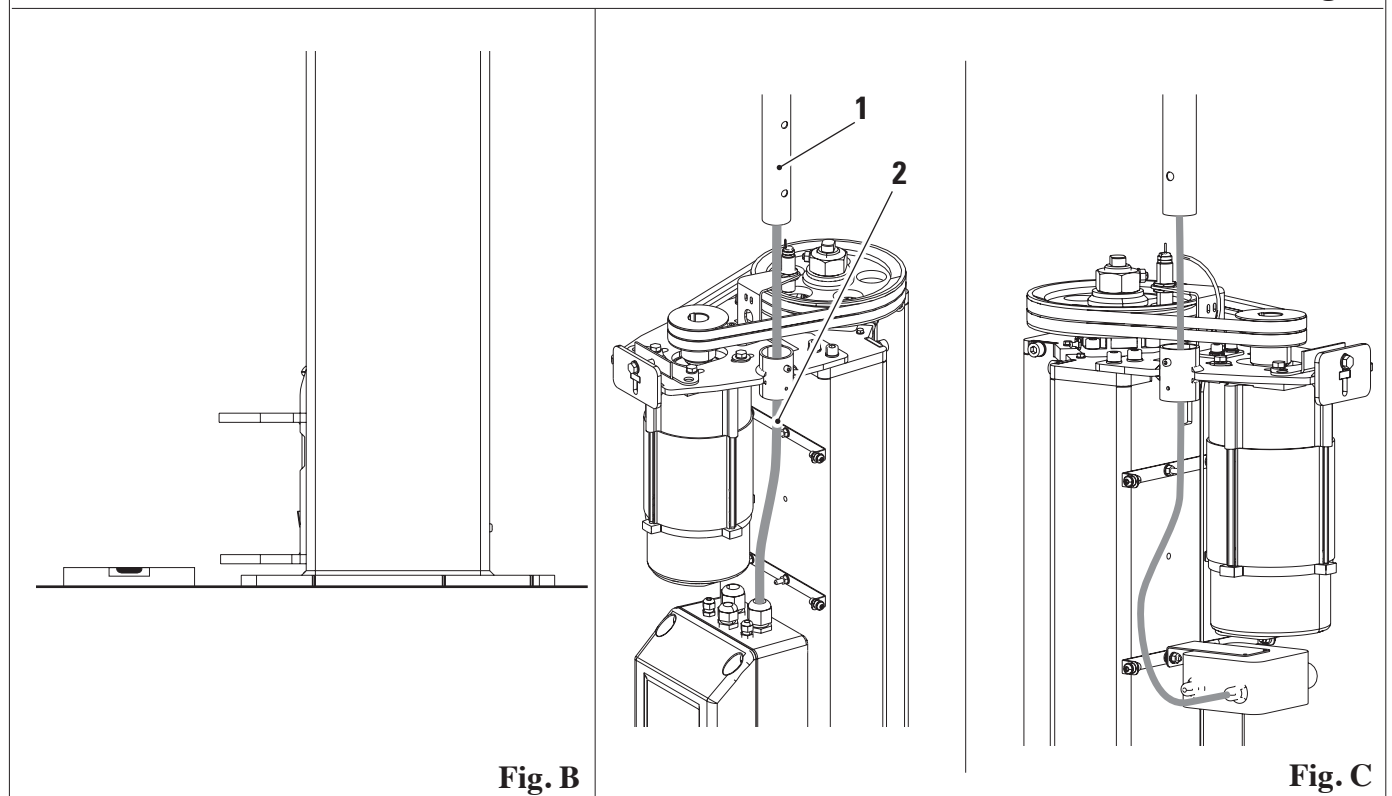

Fig. B

Fig. C

7.4 CONTROLLO TENSIONE

Controllare che la tensione per la quale è predisposto l'impianto corrisponda a quella di rete.
In caso contrario occorre sostituire l'impianto elettrico ed effettuare il cambio tensione del motore.

7.5 ALLACCIAMENTO RETE

Versione trifase: 400V 50Hz 380V 60Hz

sezione cavo $\geq 4\text{mm}^2$ 3poli + terra P=11KW I=20A

Versione trifase: 230V 50Hz 220V 60Hz

sezione cavo $\geq 6\text{mm}^2$ 3poli + terra P=11KW I=32A

Controllare inoltre che a monte si trovi un dispositivo di interruzione automatica contro le sovracorrenti dotato di salvavita da 30mA.

7.6 COLLEGAMENTI

- Passare il cavo di alimentazione all'interno della cassetta attraverso il pressacavo e collegare i fili alla morsettieria (vedi schema elettrico).

Prima installazione.

Attenzione: Il sollevatore può trovarsi con i carrelli non allineati a causa dell'imballo.

Portare i carrelli a terra (fine corsa discesa) seguendo le indicazioni del cap. "8.5" del manuale.

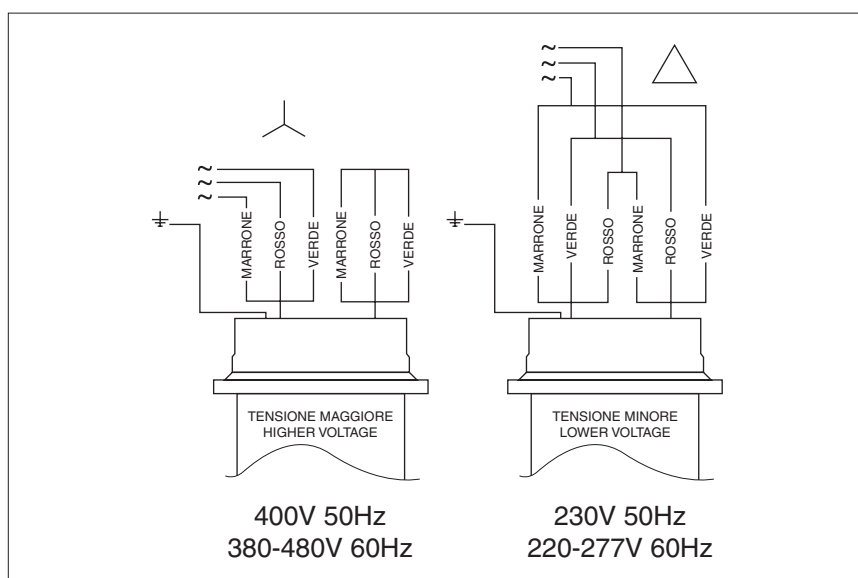
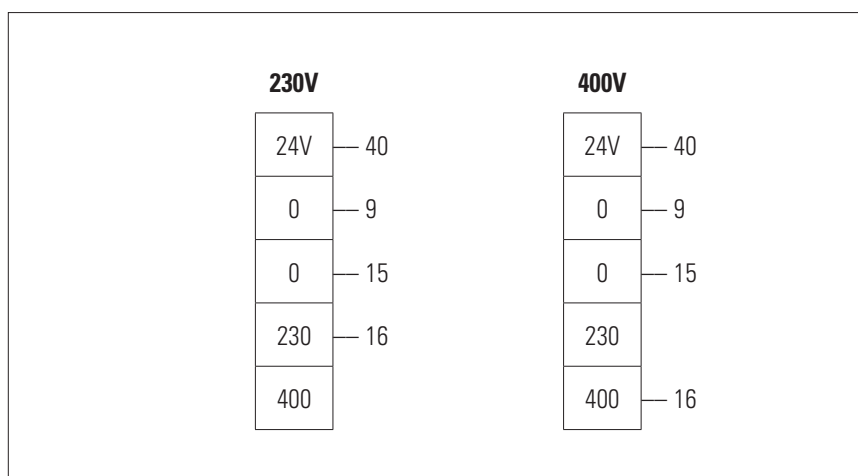

Gli interventi sulla parte elettrica, anche di lieve entità, richiedono l'opera di personale professionalmente qualificato.

COLLEGAMENTO MOTORE

COLLEGAMENTO TRASFORMATORE

FUSIBILI

L'impianto elettrico è predisposto per una tensione corrispondente a quella indicata sulla targa matricola.

7.7 COMPLETAMENTO E CONTROLLO

- Azionando il comando di discesa, agire manualmente sul finecorsa inferiore: la discesa deve arrestarsi.
- Azionare il comando di salita fino al completo innalzamento dei carrelli controllando che l'arresto avvenga per intervento del finecorsa superiore.
- Riempire le vaschette delle colonne con l'olio ESSO GEAR OIL GX 85W - 140 fino al livello indicato (vedi cap. 10).
- Montare il piastrino sensore puleggia su entrambe le colonne Fig. **A**. Controllare che tra il sensore e la puleggia ci sia una distanza di 0,5mm (Fig. **B**).

- Montare i carter come illustrato in Fig. **C**:
- montare il carter (**1**) fissandolo ai supporti (**2**);
- montare il carter (**3**) fissandolo al carter (**1**) e ai supporti (**4**)
- montare il carter (**5**) fissandolo ai carter (**1**) e (**3**).



La targhetta di identificazione deve rimanere ben visibile dopo l'installazione.

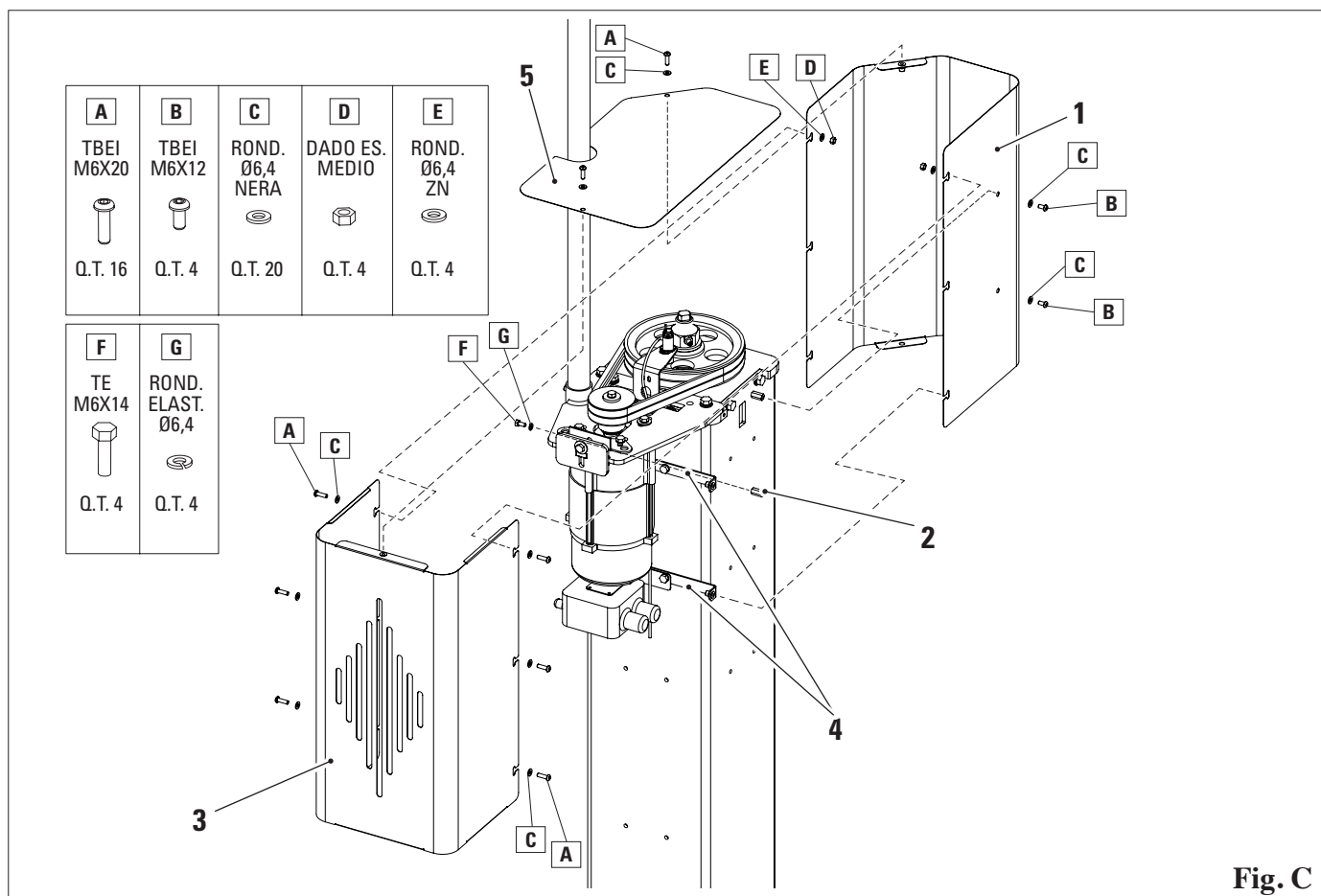
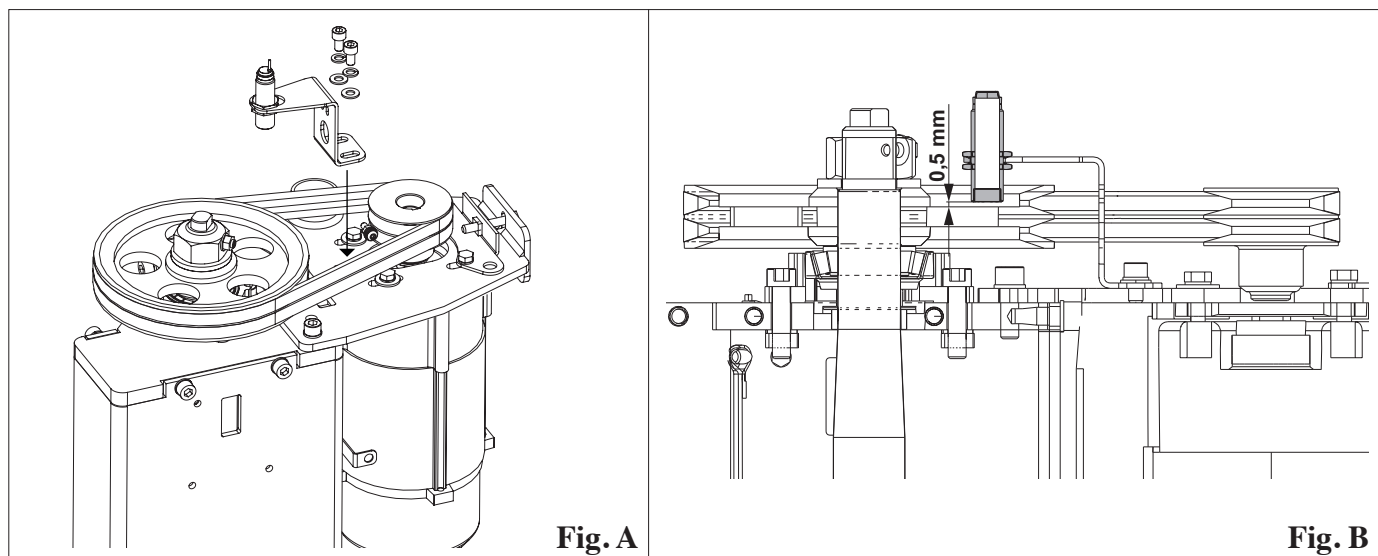

7.8 MONTAGGIO BRACCI



- Portare i carrelli ad una altezza di 70-80 cm.

- Montare i bracci lunghi e i bracci corti:

smonare la ruota dentata (1) svitando le rispettive viti; togliere il perno (2); infilare il braccio all'interno delle ali carrello e rimontare il perno (2) e la ruota dentata (1) fissandola con le viti.

7.9 USO DI ACCESSORI

Il sollevatore può essere usato con accessori per facilitare il lavoro dell'operatore.

  *E' consentito solo l'uso di accessori originali della casa produttrice.*

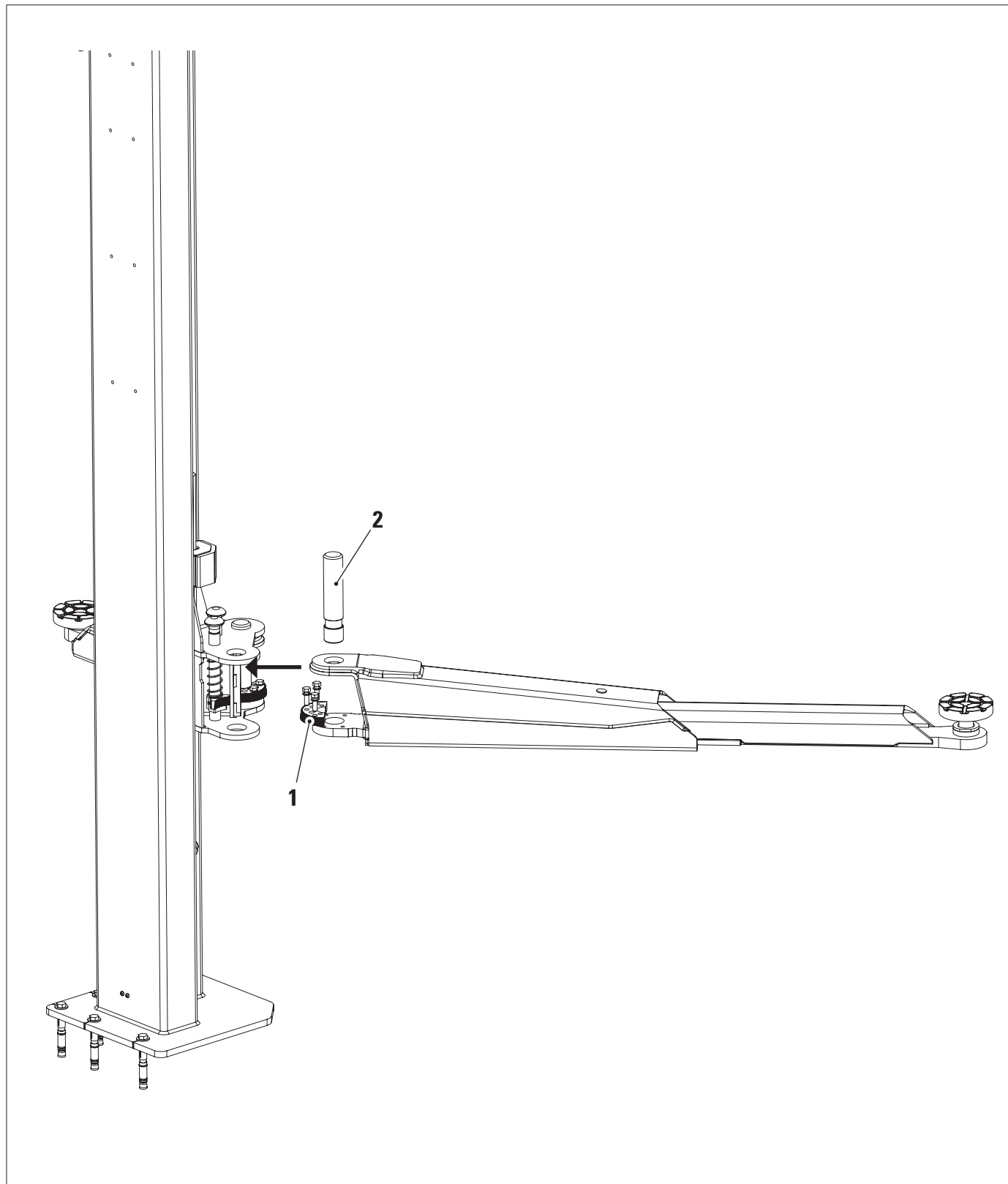

CAP. 8 USO DEL SOLLEVATORE



8.1 PRECAUZIONI D'USO



È assolutamente vietato rimanere sotto il veicolo durante le operazioni di salita e discesa!

- Controllare che durante le manovre operative non si verifichino condizioni di pericolo, arrestare immediatamente la macchina nel caso si riscontrino irregolarità funzionali, ed interpellare il servizio assistenza del rivenditore autorizzato.
- Controllare che l'area di lavoro intorno alla macchina sia sgombra di oggetti potenzialmente pericolosi e non vi sia presenza di olio (o altro materiale viscido) sparso sul pavimento in quanto potenziale pericolo per l'operatore.
- L'operatore deve indossare adeguato abbigliamento di lavoro, occhiali protettivi, guanti e maschera per evitare il danno derivante dalla proiezione di polvere o impurità, non devono essere portati oggetti pendenti come braccialetti o similari, devono essere protetti i capelli lunghi con opportuno accorgimento, le scarpe devono essere adeguate al tipo di operazione da effettuare.
- Accertarsi che lo smontaggio di parte del veicolo non alteri la ripartizione del carico oltre i limiti accettabili previsti.
- Posizionare sullo zero l'interruttore generale quando si effettuano operazioni sul veicolo sollevato.

8.2 MOVIMENTAZIONE E COMPORTAMENTO DURANTE LE FUNZIONI DEL SOLLEVATORE

Attenersi alle seguenti procedure descritte di seguito:

- Identificare il peso del veicolo.
 - Identificare la distribuzione di carico.
 - Assicurarsi di centrare il veicolo rispetto al ponte con la massima precisione possibile
 - Identificare i punti di presa del veicolo ed attenersi a quanto prescritto dal costruttore.
- **Procedura di corretto posizionamento tamponi:** utilizzare le mani come presa per far uscire il braccio telescopico (vedi figura); indirizzare il tampone e posizionarlo sui punti di presa del veicolo precedentemente identificati. Non usare piedi o altri sistemi diversi da quelli elencati.
- Alzare il carrello ad un'altezza poco superiore di 30cm e con delle pressioni al veicolo verificare la corretta stabilità dei punti di presa e l'innesto degli arresti.
 - Durante il movimento di salita e discesa, controllare il punto di appoggio sul veicolo.

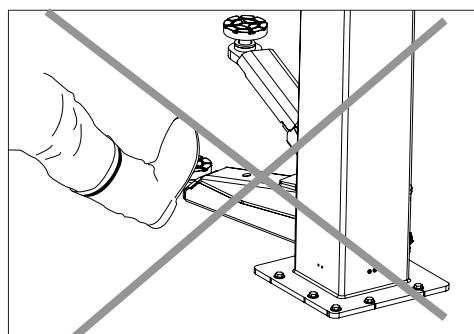
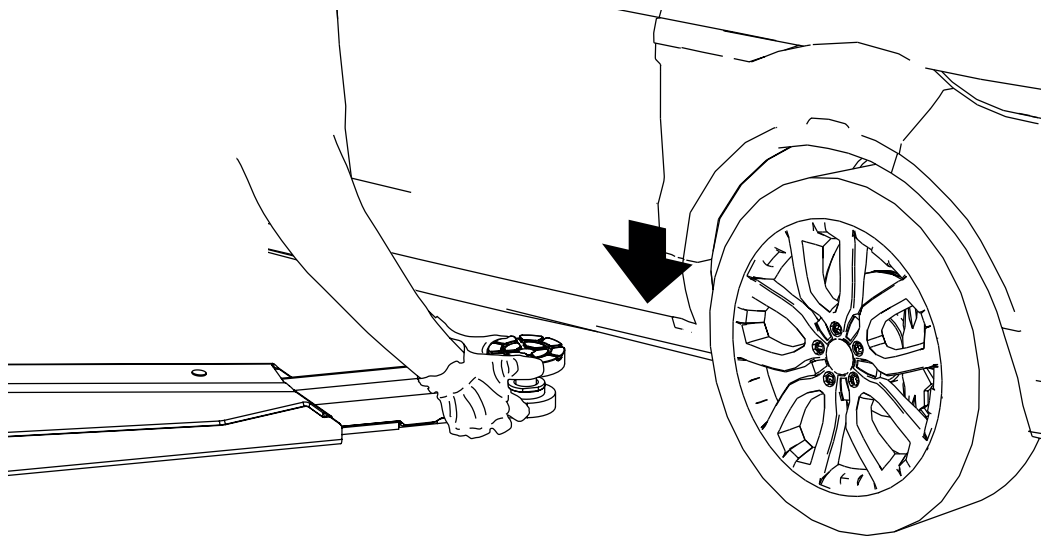

8.3 IDENTIFICAZIONE DEI COMANDI E LORO FUNZIONI

 Scatole comando cod. **047303060 - 047303070 / 047303080**

 Identificazione comandi: **INTERUTTORE (1), PULSANTE (2), PULSANTE (3) AVVISATORE ACUSTICO (4), PULSANTE DI EMERGENZA (5)**

Funzione:

	<ul style="list-style-type: none"> • Circuito elettrico disattivato • Posizione lucchettabile
	<ul style="list-style-type: none"> • Circuito elettrico attivato • TEqLINK attivato
	<ul style="list-style-type: none"> • Pulsanti (2) e (3) disattivati • TEqLINK attivato • Posizione lucchettabile

	Premuto: movimentazione in salita
	Premuto: movimentazione in discesa
	Premuto: disattiva il circuito elettrico
	Attivo: sollevatore in blocco e carrelli ad altezza pericolosa con comando discesa azionato

047303060

Scatola comando con interruttore e pulsanti salita e discesa.

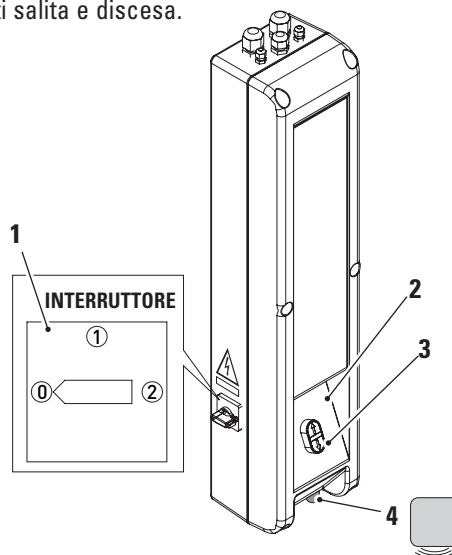
047303070 / 047303080

Doppia scatola comando con interruttore, pulsanti salita e discesa, pulsante di emergenza.

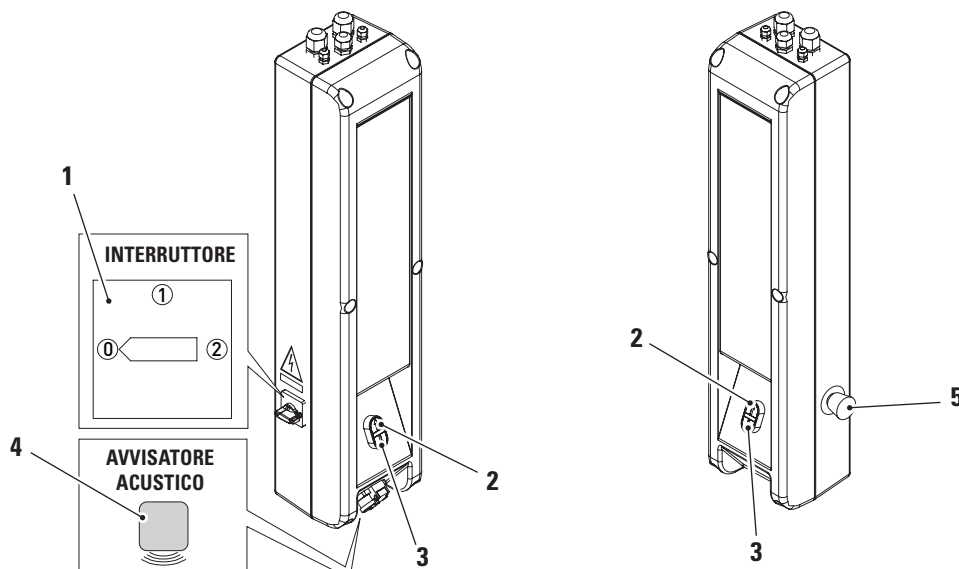

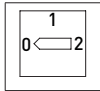
PROCEDURA DI EMERGENZA: DISCESA IN ASSENZA DI TENSIONE

Ruotare l'interruttore sulla posizione 0 (togliere la possibilità di un ritorno dell'alimentazione elettrica).

- **DISCESA DI EMERGENZA:** Nel caso venisse a mancare corrente è possibile riportare al suolo il carico togliendo i carter sulla sommità delle colonne e facendo ruotare le viti di manovra, in modo alternato colonna comando e colonna opposta in modo da non superare i 50 mm di differenza tra le quote carrelli, con una chiave da mm17.

Una volta riabilitato il circuito elettrico, bisogna far resettare i contattori facendo fare al ponte una salita per 5 cm poi farlo scendere.



ATTENZIONE! L'operazione va effettuata da personale qualificato, facendo attenzione alla posizione del carico evitando squilibri tra i due carrelli che possano pregiudicare la stabilità del carico.

8.4 USO IMPROPRIO DEL SOLLEVATORE

Il sollevatore è destinato al sollevamento di veicoli con le caratteristiche previste al cap. 2. e cap. 3.

Ogni altro uso è da considerarsi improprio e irragionevole; in particolare è assolutamente vietato:

- 1) il sollevamento di persone ed animali;
- 2) il sollevamento di veicoli con persone a bordo;
- 3) il sollevamento di veicoli carichi di materiale potenzialmente pericolosi (esplosivi, corrosivi, infiammabili, ecc. ...);
- 4) il sollevamento di veicoli non posizionati sui punti di appoggio;
- 5) il sollevamento di veicoli con accessori non previsti dalla ROTARY
- 6) l'uso del sollevatore da parte di personale non adeguatamente addestrato ed autorizzato.
- 7) Uso come crick.
- 8) Uso di una sola coppia di bracci in senso longitudinale o trasversale.
- 9) Uso di un singolo braccio.
- 10) Uso dei bracci per comprimere e schiacciare.

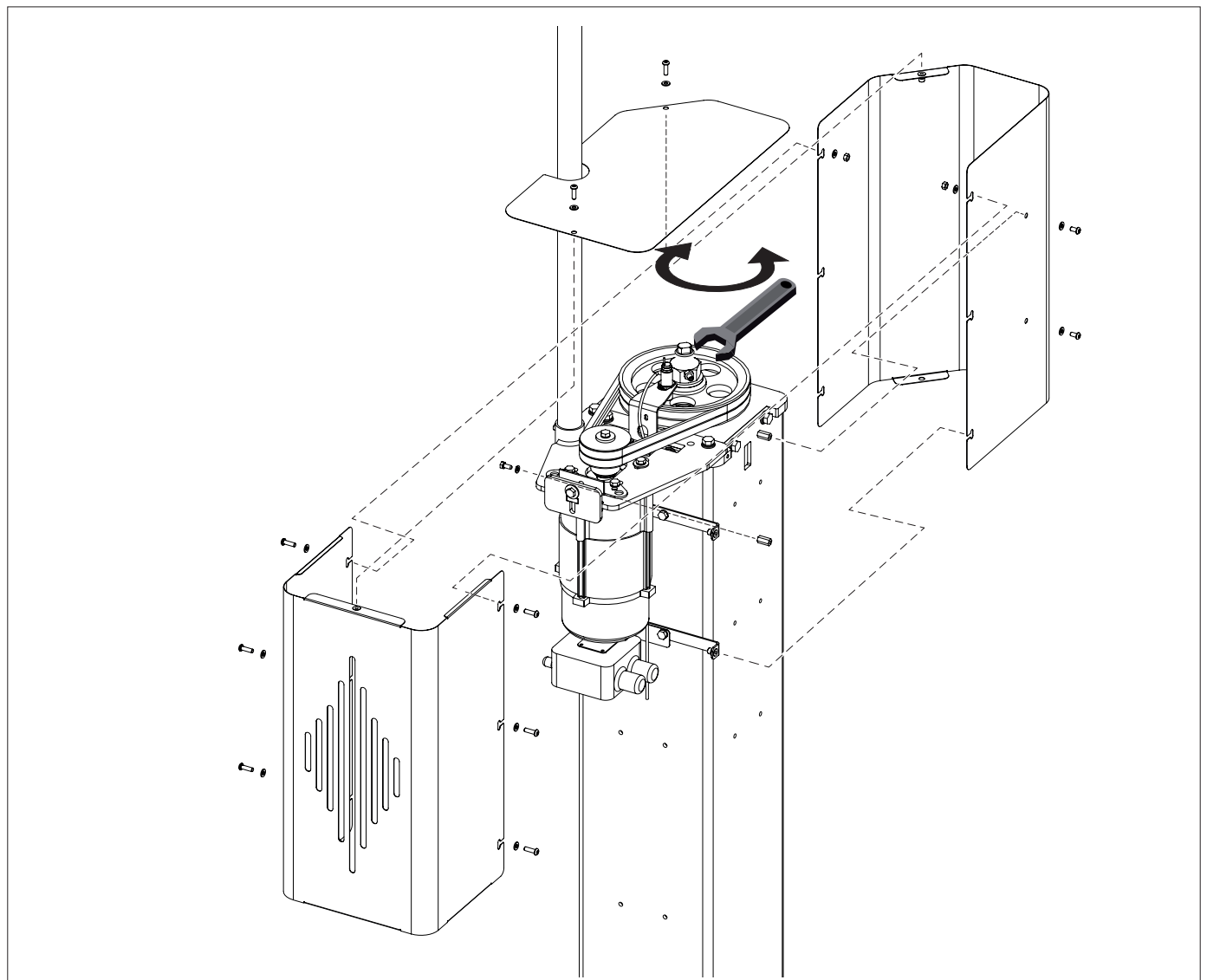

8.5 FUNZIONALITÀ DISPOSITIVO DI CONTROLLO SINCRONIZZAZIONE.

Attenzione!

Per le verifiche e le procedure di emergenza è necessario l'intervento di un tecnico specializzato poiché si opera in presenza di tensione elettrica.

All'interno del quadro è presente la scheda elettronica (1) che dispone di un LED (2) che rimane acceso quando l'interruttore è nelle seguenti condizioni:

Interruttore scatola comando cod. **047303060** - **047303070**

	<ul style="list-style-type: none"> • Circuito elettrico attivato • TEqLINK attivato
	<ul style="list-style-type: none"> • Pulsanti (4) e (5) disattivati • TEqLINK attivato • Posizione lucchettabile

Inconveniente: ponte in blocco (segnalazione avvisatore acustico).

Rimedio: è possibile la discesa di emergenza (discesa in singolo).

- Se il ponte si trova in condizione di blocco è possibile far scendere i carrelli.

- Ruotare su

- Togliere il coperchio della cassetta elettrica.
 - Spostare verso il basso la leva (3) in manuale (A).

- Ruotare su

Discesa singola dei carrelli. Azionare il comando di discesa e contemporaneamente premere:

- pulsante **P1** per muovere il carrello della colonna comando; pulsante **P2** per muovere il carrello della colonna opposta.

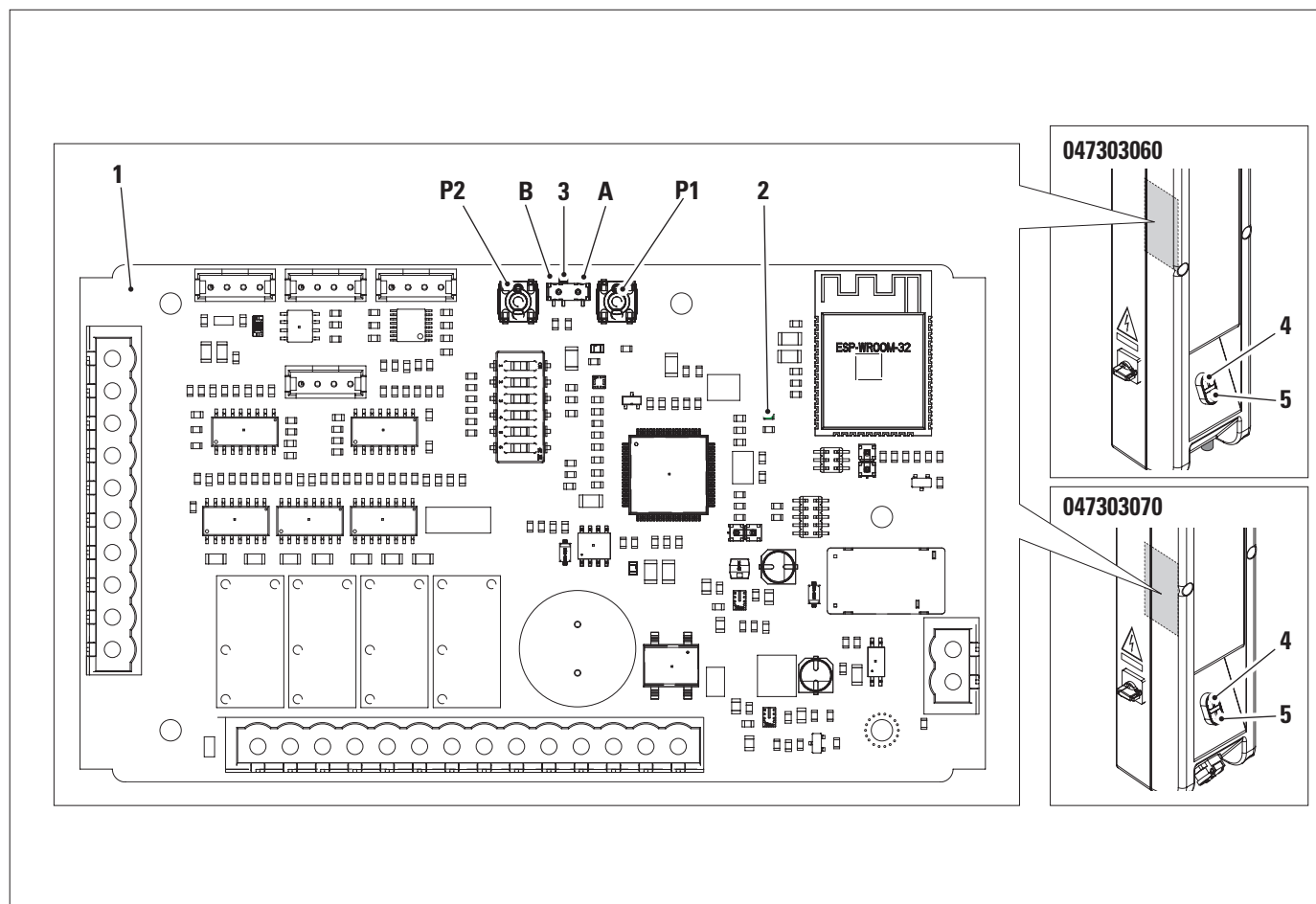



Attenzione: durante la discesa in manuale il sistema di sincronizzazione carrelli non è attivo. Manovre da effettuate correttamente e con molta attenzione per evitare il disallineo pericoloso del veicolo.



- Fare scendere entrambi i carrelli, l'ultimo che giunge a fine corsa discesa resetta il blocco (avvisatore acustico spento con comando di discesa azionato).

- Ruotare su 

- Sulla scheda, posizionare la leva (3) su (B) (in automatico).
- Montare il coperchio della cassetta elettrica.

N.B.: in manuale è consentito solo la discesa.

Se la manovra non è fattibile, vuol dire che la scheda è in blocco di sicurezza perché ha rilevato una condizione pericolosa.

Per resettare il blocco di sicurezza operare nel seguente modo:

- Ruotare su 

- sulla scheda, posizionare la leva (3) su (A) (in manuale);

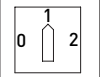
- premere contemporaneamente i pulsanti **P1** e **P2** e ruotare  ;

- tenere premuti i pulsanti **P1** e **P2** per 5 secondi;
- Il led (1), già acceso, lampeggerà una volta.
- Posizionare la leva su (3) su (B) (in automatico).

Attenzione:

- se il blocco è stato generato da un guasto hardware (scheda o impianto elettrico), il blocco si ripresenterà immediatamente;
- se il guasto è nella scheda occorrerà sostituirla;
- se il guasto è nell'impianto occorrerà rimuoverlo.

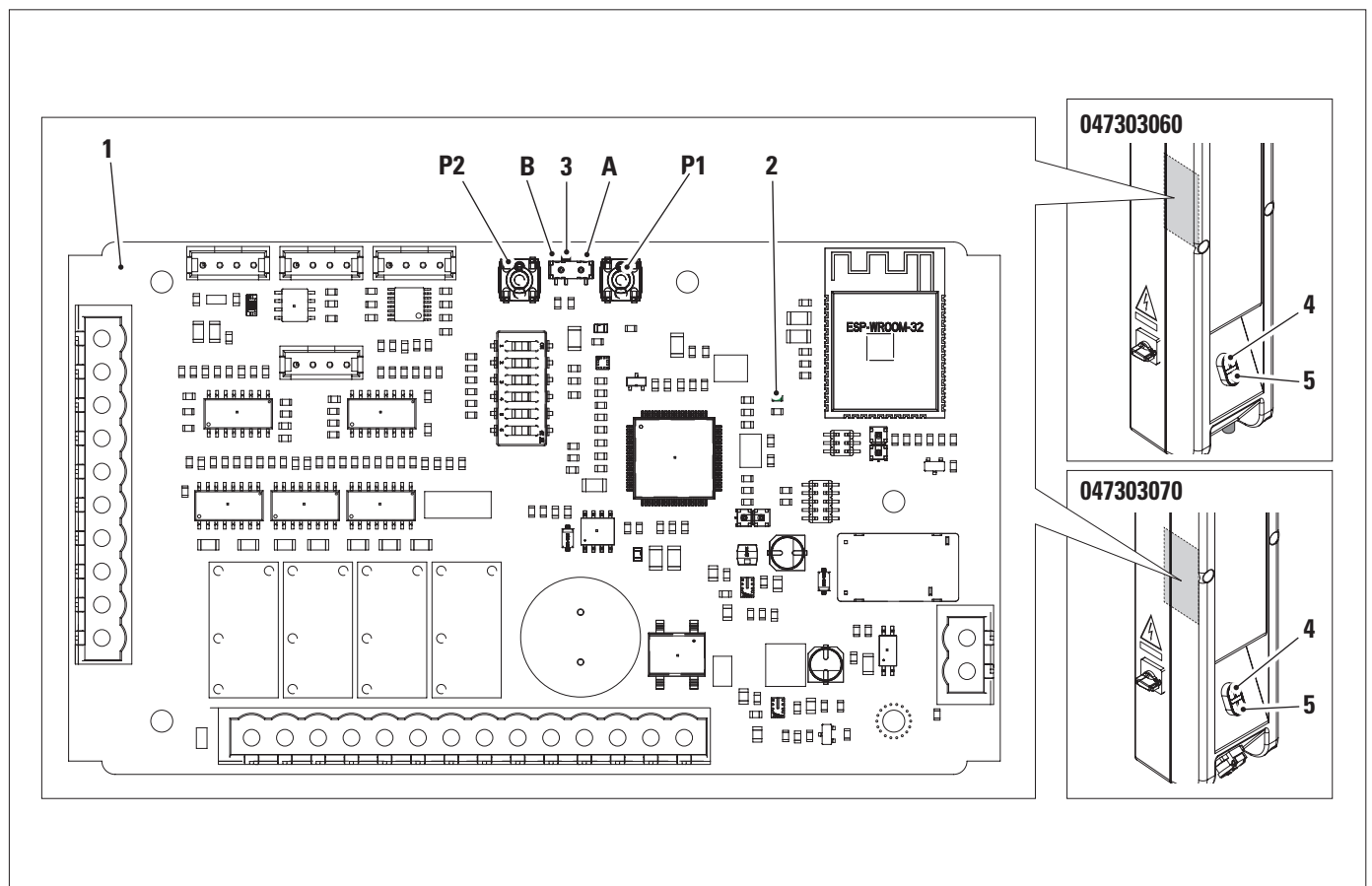

CAP. 9 DISPOSITIVI DI SICUREZZA

Interruttore generale lucchettabile

Interruttore scatola comando cod. 047303060 - 047303070	
	<ul style="list-style-type: none"> • Circuito elettrico disattivato • Posizione lucchettabile
	<ul style="list-style-type: none"> • Pulsanti disattivati • TEqLINK attivato • Posizione lucchettabile

Sistema a uomo presente

Il ponte è dotato di un sistema operativo del tipo "uomo presente": le operazioni di salita o di discesa, sono immediatamente interrotte al rilascio dell'interruttore-invertitore di comando.

Arresti meccanici

Il ponte è dotato di arresti meccanici che agiscono in caso di anomalie del finecorsa, al termine della corsa di salita o di discesa. In tali situazioni comandare a scatti la manovra opposta all'operazione precedente per una corsa di 5-10 cm.

Controllare il finecorsa interessato, ed eventualmente sostituirlo.

Oltre agli arresti meccanici di cui sopra può verificarsi il disinserimento della sonda termica del motore; il riarmo automatico di quest'ultima avverrà dopo circa 3 minuti.

Riallineamento carrelli



Ogni manomissione o modifica dell'apparecchiatura non preventivamente autorizzate dal costruttore sollevano quest'ultimo da danni derivati o riferibili agli atti suddetti.

La rimozione o manomissione dei dispositivi di sicurezza comporta una violazione delle Norme Europee sulla sicurezza.

Quando la differenza di altezza tra i due carrelli raggiunge i 18mm, il dispositivo di controllo interviene automaticamente per ripristinare il corretto allineamento.

Blocco di emergenza

Questo tipo di blocco interviene in caso di:

- disallineamento dei carrelli superiore a 40 mm;
- blocco dei motori.

Manovre permesse in condizioni di emergenza

- Quando il sollevatore si trova in condizione di emergenza (vedi paragrafo precedente) non è consentita nessuna manovra di salita o discesa mediante i comandi; per il ripristino del funzionamento contattare il Servizio Assistenza
- Se occorresse togliere il veicolo dal ponte è possibile far scendere i carrelli azionando manualmente le pulegge.

Arresto usura chiocciolate

Utilizzando il sollevatore oltre il limite indicato al Cap. 10.2 si avrà l'intervento dell'arresto usura chiocciolate.

L'intervento del dispositivo si attiva quando i carrelli arrivano sui fine corsa di discesa.

Viene segnalato dall'avvisatore acustico, attivo con modalità: **1s ON e 1s OFF**.

CAP. 10 MANUTENZIONE

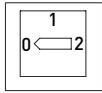

Posizionare sullo 0 (zero) l'interruttore generale quando si effettuano operazioni di manutenzione.



Attenzione: organi meccanici in movimento. La rimozione delle carterature è da considerarsi a rischio di chi la esegue.



10.1 ATTIVITÀ DI MANUTENZIONE

Effettuare controlli periodici sui dispositivi di sicurezza ogni 3 mesi



È necessario una valutazione di vitare sidua dopo 10 anni di attività del sollevatore, eseguita da un tecnico qualificato, preferibilmente autorizzato dal costruttore.

• MENSILE

Chiocciolate portanti - Smontare le tendine di protezione con i carrelli a 50 cm da terra, controllare le chiocciolate utilizzando il piastrino (1) in dotazione: si deve inserire nella gola come in figura; se non si riesce a posizionare il lato STOP, sostituire la chiocciola.

• TRIMESTRALE

Guide di scorrimento - Lubrificare le guide di scorrimento dei pattini cospargendole con grasso (fig. B).

Cuscinetti - Togliere i carter di copertura motore ed iniettare grasso negli ingrassatori (2).

• ANNUALE

Vaschette di lubrificazione - Smontare le tendine di protezione e rabboccare la vaschetta (3) di lubrificazione con olio (ESSO GEAR OIL 85W-140 od equivalente).

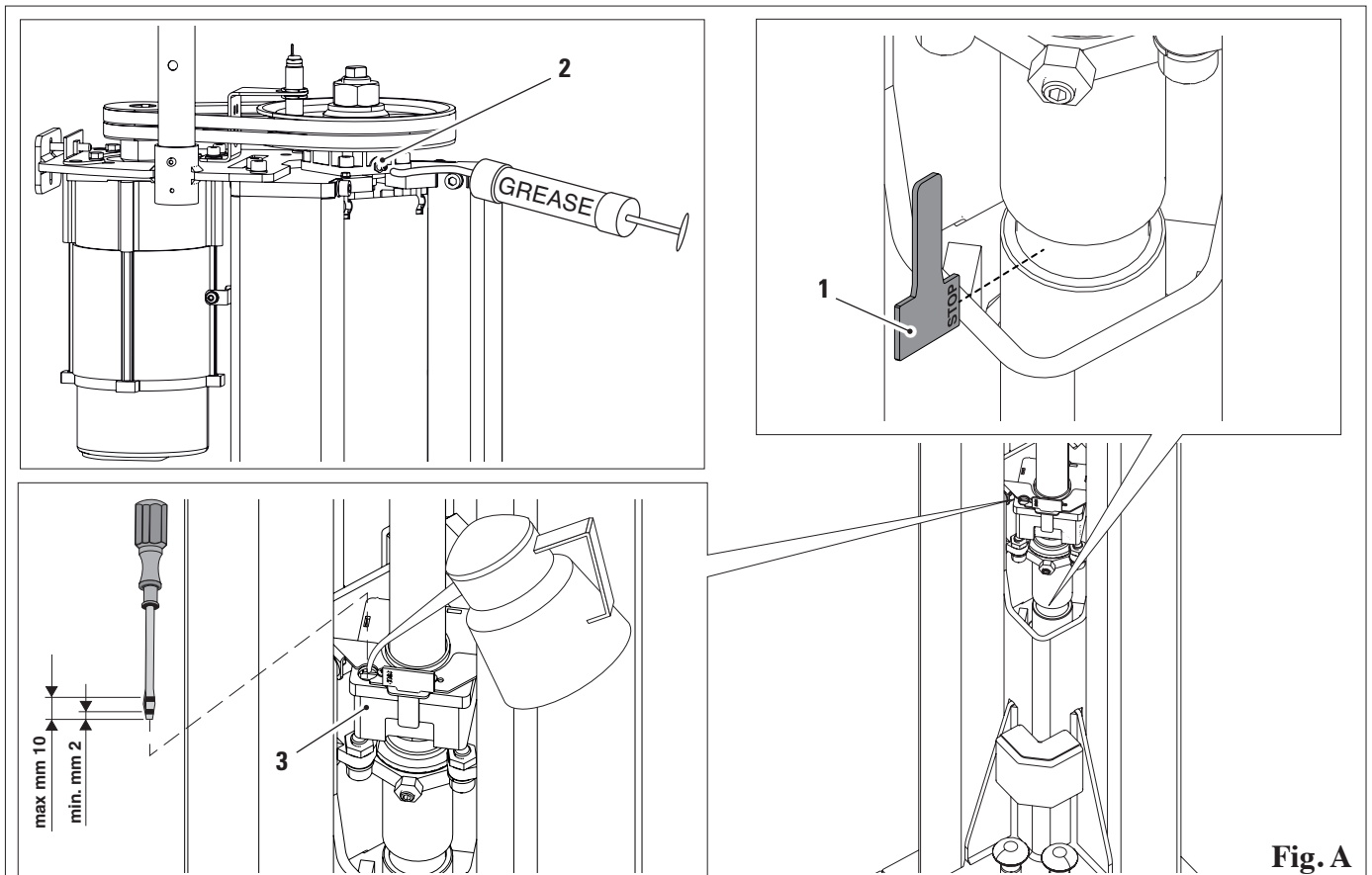

Fig. A

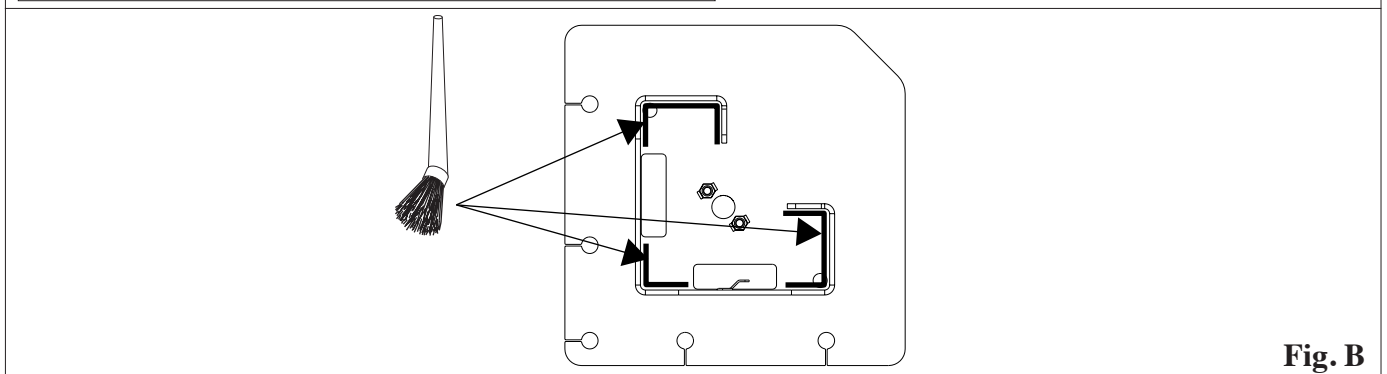

Fig. B

Piano di manutenzione programmata

Intervallo di TEMPO	Tipo di MANUTENZIONE	Piano di MANUTENZIONE	POSIZIONE*	CRITICITA'
GIORNO	STICKERS	Controllare ed eventualmente sostituire stickers di sicurezza danneggiati o illeggibili	Su colonna Su quadro	MEDIA
	BRACCI	Verificare stato del parapiedi, usura, o danni eventualmente sostituire	Bracci	MEDIA
	BRACCI	Verificare stato dei tamponi, usura, o danni eventualmente sostituire	Bracci	BASSA
MESE	CUSCINETTO	Ingrassare cuscinetto portante della vite (vedi attuale dicitura)	In testa alla vite	ALTA
	CHIOCCIOLA	Verificare stato della vite, usura, o danni eventualmente sostituire (vedere dicitura attuale)	In testa al carrello	ALTA
	CHIOCCIOLA	Verificare livello olio nella vaschetta di lubrificazione eventualmente rabboccare con olio (vedere dicitura attuale)	In testa al carrello	ALTA
	CHIOCCIOLA DI SICUREZZA	Ingrassare la contro chiocciola di sicurezza, con grasso multiuso NON usare grasso a base solida (Molicote), tipo grafite.	In testa al carrello	MEDIA
TRIMESTRE	GUIDE SCORRIMENTO	Lubrificare con grasso (privo di sospensioni solide) le guide scorrimento dei pattini dei carrelli		ALTA
	TASSELLI	Verificare l'ancoraggio dopo una decina di corse a pieno carico controllando la coppia di serraggio dei tasselli.	Su colonna	ALTA
ANNO	CINGHIA	Verificare corretto tensione della cinghia e sua usura eventualmente tensionare o sostituire	In testa alla colonna	ALTA
	VITE	Verificare stato della vite, usura, o danni eventualmente sostituire	Internamente alla colonna	ALTA
	COMPONENTI ELETTRONICI	Verificare stato dei componenti elettrici ed elettronici collegamenti integri e danni su morsettiere o connettori	Quadro elettrico	ALTA
	VERNICIATURA	Controllare danni e abrasioni su superficie verniciate eventualmente carteggiare e verniciare per evitare danni di ruggine	Colonna Carrello	MEDIA
	SALDATURE	Controllare danni e fessurazioni sulle saldature presenti su colonna, carrello e bracci. Eventualmente intervenire, pulendo la zona e ripristinando la saldatura	Colonna Carrello	ALTA
	VITI DI FISSAGGIO	Controllare serraggio di tutte le viti di fissaggio Eventualmente intervenire serrando con chiave dinamometrica		
	BRACCI	1. Pulire e lubrificare i perni 2. controllare le molle dei perni ed eventualmente sostituire e riparare 3. controllare danni presenti sui bracci e sugli arresti degli sfili 4. controllare il sistema di arresto bracci, filetti e usura, ed eventualmente sostituire	Bracci	MEDIA
	PATTINI	Controllare danni e usura dei pattini e delle guide di scorrimento. Eventualmente sostituire e spessorare i pattini, pulendo la zona e lubrificando	Carrello	MEDIA

10.2 USURA CHIOCCIOLA E SOSTITUZIONE GRUPPO VITE



L'usura della chiocciola portante porta alla rottura della chiocciola stessa; in questo caso il carrello si abbasserà di 20mm. Questa condizione viene rilevata dalla scheda elettronica quando si attivano i finecorsa discesa, segnalato dall'avisatore acustico in funzione con modalità 1sec. ON - 1sec. OFF.

Di conseguenza la manovra di salita non si può effettuare.

La rottura della chiocciola prevede la sostituzione dell'intero gruppo vite.

Procedura sostituzione gruppo vite:

- Portare il carrello ad altezza di cca 350mm e inserire un blocco di legno (1) sotto il carrello.
- Togliere tensione alla macchina.
- Smontare tendina (2).
- Smontare le carterature (3).
- Smontare il supporto proximity (4) (attenzione: non il proximity dal suo supporto).
- Smontare le cinghie di trasmissione (5).
- Ruotare la puleggia fino a mandare a contatto il carrello col blocco di legno (fig. C).
- Smontare antirotazione vaschetta (6).
- Smontare grano e dado (7).
- Smontare viti di trattenimento (8).
- Smontare viti supporto cuscinetto (9).
- Ruotare la chiocciola fino a mandare in battuta alla chiocciola di sicurezza (senso orario) (10).
- Avvitare il golfare all'estremità della vite (11).
- Rimuovere con movimento diagonale il gruppo vite dall'interno del ponte (fig. D).
- Rieseguire le operazioni in senso inverso per il montaggio del ricambio (prestando molta attenzione al fissaggio del grano).

Eseguire il RESET vedi capitolo 8.5.

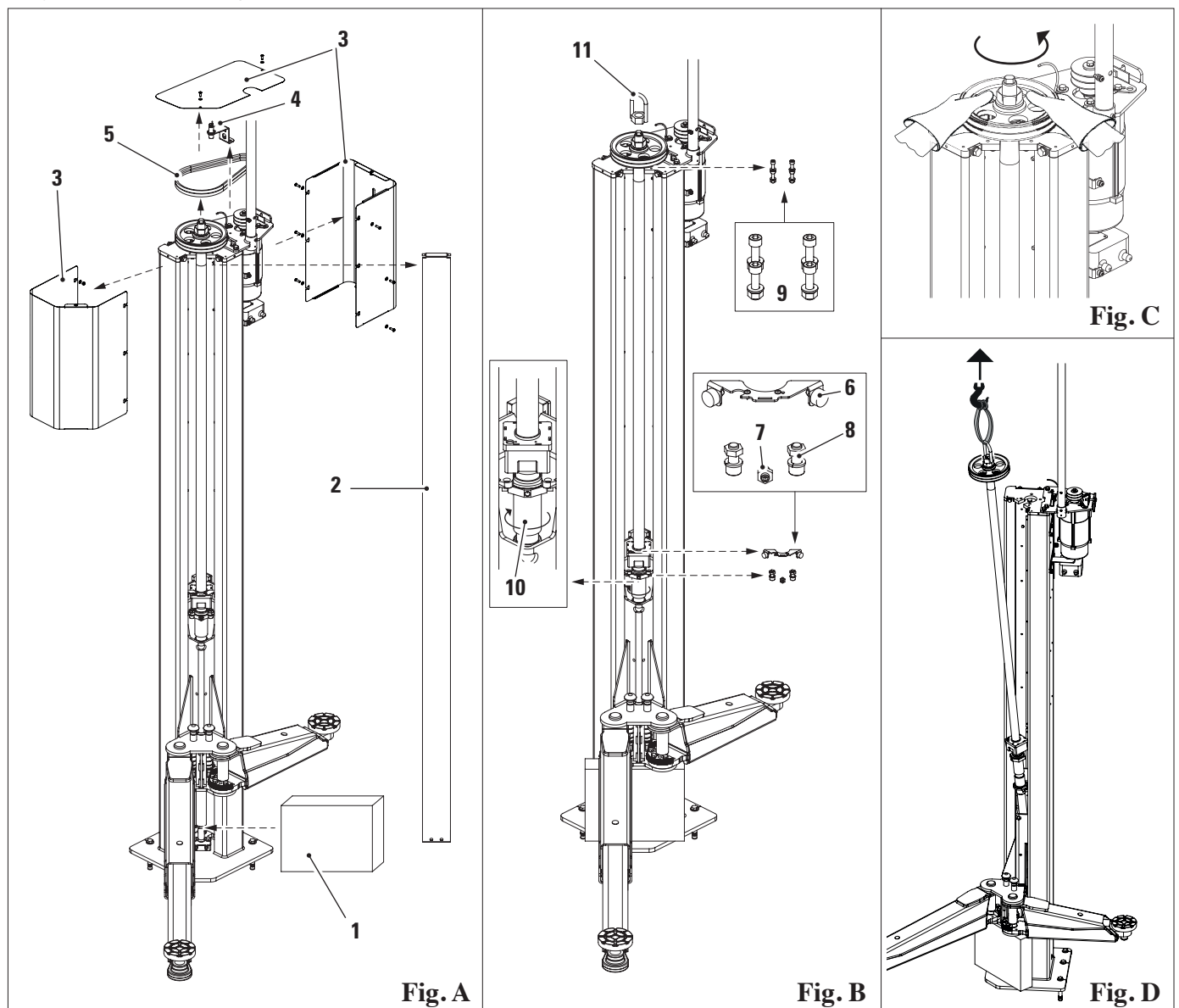

10.3 TROUBLE SHOOTING

Qui di seguito sono elencati alcuni degli inconvenienti possibili durante il funzionamento del Ponte. La ROTARY declina ogni responsabilità per danni dovuti a persone, animali e cose, per intervento da parte di personale non autorizzato. Pertanto al verificarsi del guasto si raccomanda di contattare tempestivamente l'assistenza tecnica in modo da ricevere le indicazioni per poter compiere operazioni e/o regolazioni in condizioni di massima sicurezza, evitando il rischio di causare danni a persone, animali e cose.



E' necessario l'intervento dell'assistenza tecnica. Vietato eseguire intervento.



INCONVENIENTE	CAUSA	INTERVENTO
Nessun funzionamento. Avvisatore acustico spento.	Tensione di alimentazione.	Controllare la tensione nei cavi di alimentazione. Controllare interruttore / invertitore del sollevatore. Controllare fusibili di linea. Controllare trasformatore comandi e relativi fusibili.
Non completa la corsa. Avvisatore acustico spento.	Disinserimento sonda termica motore.	Attendere il riarmo.
Nessun funzionamento. Avvisatore acustico acceso.	Sollevatore in blocco di emergenza. Interruttore di prossimità. Motore fermo.	Vedi capitolo 8.5 Registrare / sostituire. Controllare cinghie motore.
Nessun funzionamento. Avvisatore acustico acceso: 2sec. ON / 2 sec. OFF	Switch scheda su manuale dopo aver resettato il blocco.	Mettere switch su automatico.
Non solleva i carrelli a fine corsa discesa. Avvisatore acustico acceso: 1sec. ON / 1 sec. OFF	Blocco per usura chiocciola.	Vedi capitolo 10.2.
Nessun funzionamento, nemmeno in manuale. Avvisatore acustico acceso.	Blocco di sicurezza.	Vedi capitolo 8.5

CAP. 11 SMALTIMENTO-ROTTAMAZIONE

11.1 SMONTAGGIO

Il lavoro di smontaggio può essere effettuato soltanto da personale specializzato autorizzato. Solo elettricisti qualificati possono lavorare sull'impianto elettrico.

1. Per effettuare il lavoro di smontaggio, spegnere l'apparecchio con l'interruttore principale (posizione OFF).
2. Staccare l'alimentazione elettrica.
3. Svuotare il serbatoio dell'olio. Smaltire l'olio idraulico e liquidi di funzionamento, come descritto nel capitolo 11.3.
4. Rimuovere il grasso e altre sostanze chimiche. Smaltire come descritto nel capitolo 11.3
5. Le operazioni di smontaggio vanno eseguite seguendo in ordine inverso le fasi di montaggio (vedi cap. 7).

11.2 ACCANTONAMENTO

- In caso di accantonamento per lungo periodo è necessario scollegare le fonti di alimentazione, svuotare il/i serbatoio/i contenenti i liquidi di funzionamento e provvedere alla protezione di quelle parti che potrebbero risultare danneggiate in seguito al deposito di polvere.

- Provvedere ad ingrassare le parti che si potrebbero danneggiare in caso di essiccazione.
- In occasione della rimessa in funzione sostituire le guarnizioni indicate nella parte ricambi.

11.3 SMALTIMENTO

Procedure ambientali per lo smaltimento

Prevenire rischi ambientali.

Evitare il contatto o inalazione di sostanze tossiche come fluido idraulico.

Oli e lubrificanti sono inquinanti dell'acqua entro i termini della legge sulla gestione delle acque WGH. Smaltire questi sempre in modo ecologico nel rispetto delle normative vigenti nel proprio paese

L'olio idraulico a base di olio minerale è un inquinante dell'acqua ed è combustibile. Consultare la scheda dati di sicurezza relativa allo smaltimento.

Assicurarsi che nessun olio idraulico, lubrificanti, o materiali per la pulizia contaminino il suolo o venga eliminato nella rete fognaria.

Imballaggio

Non smaltire con i rifiuti domestici! La confezione contiene alcuni materiali riciclabili, che non devono essere smaltiti con i rifiuti domestici.

1. Smaltire i materiali di imballaggio in conformità con le normative locali.

Olio, grasso e altre sostanze chimiche.

1. Quando si lavora con oli, grassi e altre sostanze chimiche, rispettare le normative ambientali che si applicano al prodotto in questione.
2. Smaltire l'olio, grassi e altre sostanze chimiche nel rispetto delle normative ambientali che si applicano nel vostro paese.

Metalli / Rifiuti elettronici

Questi devono sempre essere correttamente smaltiti da una ditta certificata.

RAPPORTO DI INSTALLAZIONE

OPERAZIONE DI CONTROLLO
DA COMPILARE A CURA DELL'INSTALLATORE

Sollevatore modello _____

Matricola _____

Verifica della idoneità della pavimentazione	<input type="checkbox"/>
Verifica della tensione di alimentazione	<input type="checkbox"/>
Interruttore generale	<input type="checkbox"/>
Comando salita e discesa	<input type="checkbox"/>
Corretto movimento del carrello - comando di azionamento	<input type="checkbox"/>
Controllo funzionamento fine corsa di discesa	<input type="checkbox"/>
Controllo coppia di serraggio dei tasselli	<input type="checkbox"/>
Controllo corretto scorrimento dei bracci telescopici	<input type="checkbox"/>
Controllo corretto inserimento e sgancio degli arresto bracci	<input type="checkbox"/>
Controllo livello del dispositivo di lubrificazione della vite	<input type="checkbox"/>
Controllo lubrificazione delle guide di scorrimento	<input type="checkbox"/>
Controllo della presenza e collocazione degli adesivi	<input type="checkbox"/>
Portata	<input type="checkbox"/>
Avvertenze	<input type="checkbox"/>
Matricola	<input type="checkbox"/>

Firma e timbro dell'installatore

Data di installazione

VISITA PERIODICA

Operazione di controllo	data	firma	data	firma	data	firma	data	firma	data	firma
	Verifica stato di usura chiocciola	<input type="checkbox"/>		<input type="checkbox"/>		<input type="checkbox"/>		<input type="checkbox"/>		<input type="checkbox"/>
Interruttore generale	<input type="checkbox"/>		<input type="checkbox"/>		<input type="checkbox"/>		<input type="checkbox"/>		<input type="checkbox"/>	
Comando salita e discesa	<input type="checkbox"/>		<input type="checkbox"/>		<input type="checkbox"/>		<input type="checkbox"/>		<input type="checkbox"/>	
Controllo funzionamento fine corsa di discesa	<input type="checkbox"/>		<input type="checkbox"/>		<input type="checkbox"/>		<input type="checkbox"/>		<input type="checkbox"/>	
Controllo coppia di serraggio dei tasselli	<input type="checkbox"/>		<input type="checkbox"/>		<input type="checkbox"/>		<input type="checkbox"/>		<input type="checkbox"/>	
Controllo corretto scorrimento dei bracci telescopici	<input type="checkbox"/>		<input type="checkbox"/>		<input type="checkbox"/>		<input type="checkbox"/>		<input type="checkbox"/>	
Controllo corretto inserimento e sgancio degli arresto bracci	<input type="checkbox"/>		<input type="checkbox"/>		<input type="checkbox"/>		<input type="checkbox"/>		<input type="checkbox"/>	
Controllo livello del dispositivo di lubrificazione della vite	<input type="checkbox"/>		<input type="checkbox"/>		<input type="checkbox"/>		<input type="checkbox"/>		<input type="checkbox"/>	
Controllo lubrificazione delle guide di scorrimento	<input type="checkbox"/>		<input type="checkbox"/>		<input type="checkbox"/>		<input type="checkbox"/>		<input type="checkbox"/>	
Controllo della presenza e collocazione degli adesivi	<input type="checkbox"/>		<input type="checkbox"/>		<input type="checkbox"/>		<input type="checkbox"/>		<input type="checkbox"/>	
Controllo integrità dei tamponi di sollevamento	<input type="checkbox"/>		<input type="checkbox"/>		<input type="checkbox"/>		<input type="checkbox"/>		<input type="checkbox"/>	
Portata	<input type="checkbox"/>		<input type="checkbox"/>		<input type="checkbox"/>		<input type="checkbox"/>		<input type="checkbox"/>	
Avvertenze	<input type="checkbox"/>		<input type="checkbox"/>		<input type="checkbox"/>		<input type="checkbox"/>		<input type="checkbox"/>	
Matricola	<input type="checkbox"/>		<input type="checkbox"/>		<input type="checkbox"/>		<input type="checkbox"/>		<input type="checkbox"/>	

INDEX

CHAP. 1	SYMBOLES UTILISÉS DANS LA NOTICE	FR_2
CHAP. 2	PRÉSENTATION	FR_3
2.1	DESCRIPTION DU PONT ELEVATEUR.....	FR_3
2.2	DESTINATION D'USAGE.....	FR_3
CHAP. 3	DONNEES TECHNIQUES	FR_4
3.1	PRINCIPALES CARACTÉRISTIQUES TECHNIQUES	FR_4
3.2	DÉTAILS TECHNIQUES GÉNÉRAUX.....	FR_5
3.3	DONNÉES D'IDENTIFICATION DE LA MACHINE	FR_7
3.4	COMMANDES PRINCIPALES DE L'ÉLEVATEUR	FR_8
3.5.	INSTALLATION ÉLECTRIQUE.....	FR_9
CHAP. 4	NORMES GENERALES DE SECURITÈ	FR_17
4.1	INFORMATIONS SUR LES RISQUES RÉSIDUELS.....	FR_17
4.2	PLAQUES ET/OU AUTOCOLLANTS DE SÉCURITÉ.....	FR_17
4.3	FORMATION DU PERSONNEL PRÉPOSÉ.....	FR_17
4.4	APTITUDE À L'EMPLOI	FR_17
CHAP. 5	EXIGENCES D'INSTALLATION.....	FR_18
5.1	CARACTERISTIQUES MINIMES REQUISES POUR LA ZONE D'INSTALLATION.....	FR_18
5.2	EXIGENCES EN MATIÈRE DE PLANCHER	FR_19
CHAP. 6	DÉPLACEMENT ET PRÉ-INSTALLATION.....	FR_20
CHAP. 7	INSTALLATION.....	FR_21
7.1	CHEVILLES.....	FR_21
7.2	BÉTON.....	FR_21
7.3	INSTRUCTIONS POUR L'INSTALLATION	FR_22
7.4	CONTRÔLE DE LA TENSION.....	FR_23
7.5	CONNEXION AU RÉSEAU.....	FR_23
7.6	CONNEXIONS.....	FR_23
7.7	COMPLÈTEMENT DE L'INSTALLATION ET CONTRÔLE.....	FR_24
7.8	MONTAGE BRAS.....	FR_25
7.9	UTILISATION D'ACCESSOIRES	FR_25
CHAP. 8	EMPLOI DU PONT ELEVATEUR.....	FR_26
8.1	PRÉCAUTIONS POUR L'EMPLOI.....	FR_26
8.2	MANIPULATION ET COMPORTEMENT PENDANT LES FONCTIONS DE L'ÉLEVATEUR.....	FR_26
8.3	IDENTIFICATION ET FONCTION DES COMMANDES	FR_27
8.4	UTILISATION INCORRECTE DU PONT ÉLEVATEUR	FR_28
8.5	FONCTIONNALITÉ DISPOSITIF DE CONTRÔLE SYNCHRONISATION.....	FR_29
CHAP. 9	DISPOSITIFS DE SECURITE	FR_31
CHAP. 10	ENTRETIEN	FR_32
10.1	ACTIVITÉS DE MAINTENANCE.....	FR_32
10.2	USURE DE L'ÉCROU ET REMPLACEMENT DU GROUPE DE VIS	FR_34
10.3	TROUBLE SHOOTING.....	FR_35
CHAP. 11	ÉLIMINATION-MISE AU REBUT.....	FR_35
11.1	DÉMONTAGE.....	FR_35
11.2	STOCKAGE	FR_35
11.3	ÉLIMINATION	FR_35
	RAPPORT D'INSTALLATION	FR_36
	CONTROLE PERIODIQUE.....	FR_37
	INTERVENTIONS D'ENTRETIEN SPECIAL ET REPARATIONS.....	FR_38

ATTENTION !

- La présente notice constitue partie intégrante du produit. Elle devra accompagner le pont élévateur pendant toute la durée de son fonctionnement.
- Il faut donc le conserver dans un endroit connu et à portée de main afin de pouvoir le consulter en cas de doute.
- Seul le personnel convenablement formé qui a lu et compris ce manuel peut utiliser l'élévateur.
- Tout dommage provoqué par le non-respect des instructions contenues dans la présente notice ou par une utilisation incorrecte du pont élévateur décline la Société ROTARY de toute responsabilité.

CHAP. 1 SYMBOLES UTILISÉS DANS LA NOTICE

	Attention!		Obligation de consulter le manuel/le livret d'instructions
	Danger électrique		Personnel qualifié
	Danger de charges suspendues		Obligation
	Danger de chariots élévateurs et autres véhicules industriels		Interdiction de passer et de se tenir sous des charges suspendues
	Danger de pièces mobiles		Porter des chaussures de protection
	Danger d'écrasement des mains		Porter des gants
	Levage par le haut		Porter des vêtements de protection
	Interdiction		Porter des lunettes
			Obligation de déconnexion avant toute opération d'entretien ou de réparation

CHAP. 2 PRÉSENTATION

2.1 DESCRIPTION DU PONT ELEVATEUR

- Nom du produit: **ÉLÉVATEUR POUR VÉHICULES**
- Description du produit : **Élévateur électromécanique à deux colonnes avec bras télescopiques.**
Pont pour le levage au châssis

2.2 DESTINATION D'USAGE

Le produit est destiné au levage de véhicules conformément à la norme en vigueur, Directive Machines 2006/42/CE ; la capacité de charge est celle indiquée sur la plaque d'identification.

L'élevateur est conçu pour une utilisation à l'intérieur, non soumise à l'action du vent.

Il ne peut être utilisé que pour le levage de véhicules répondant aux caractéristiques suivantes:

- poids ne dépassant pas la capacité de charge de l'élevateur (voir fig. **A**) conformément à la norme UNI EN 1493:2010.
- l'élevateur respecte la répartition de la charge 2/5 - 3/5 et la condition de réversibilité exprimées dans la norme 1493:2010 (fig. **B**).
- distance minimale entre les points de levage (voie): 1000 mm (Fig. **C**).

Pour des valeurs de distance inférieures, la portée du pont élévateur est réduite. Dans ce cas ou d'autres qui ne sont pas prévus dans la présente notice, il sera opportun de prendre contact avec le fabricant.

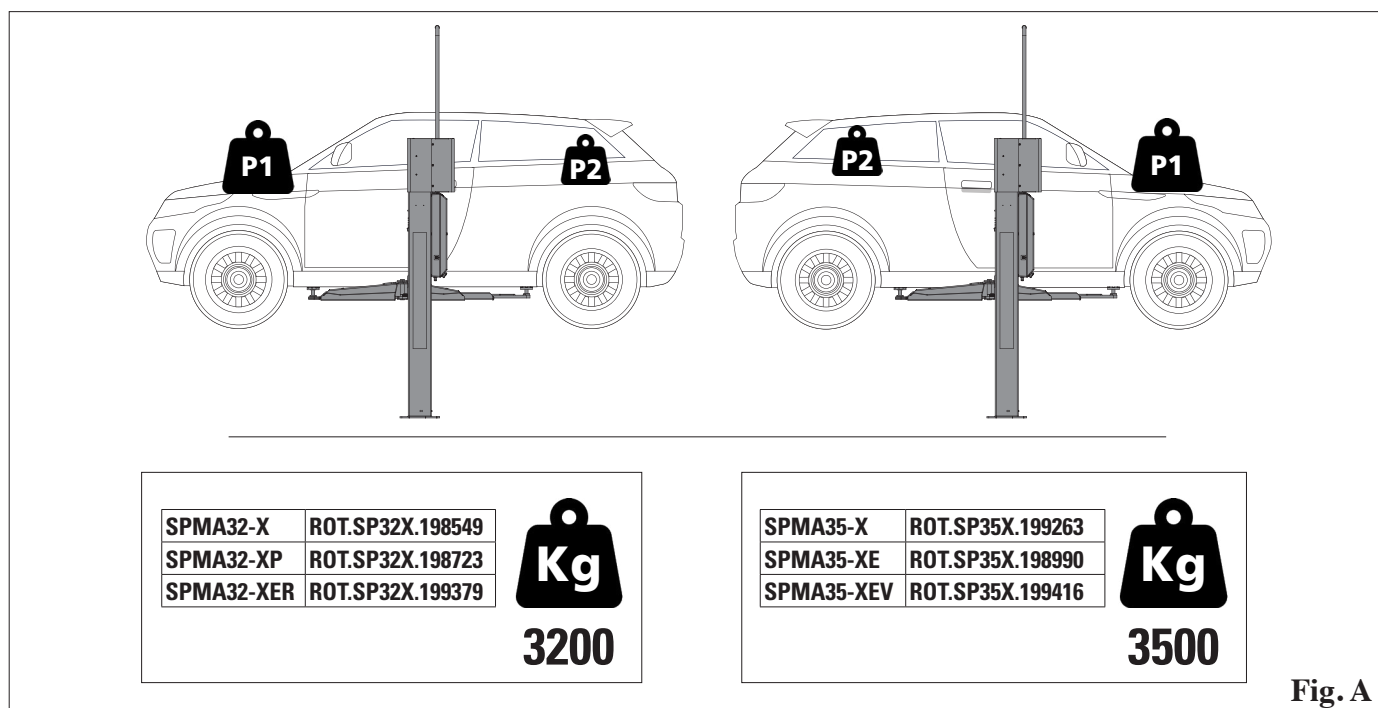
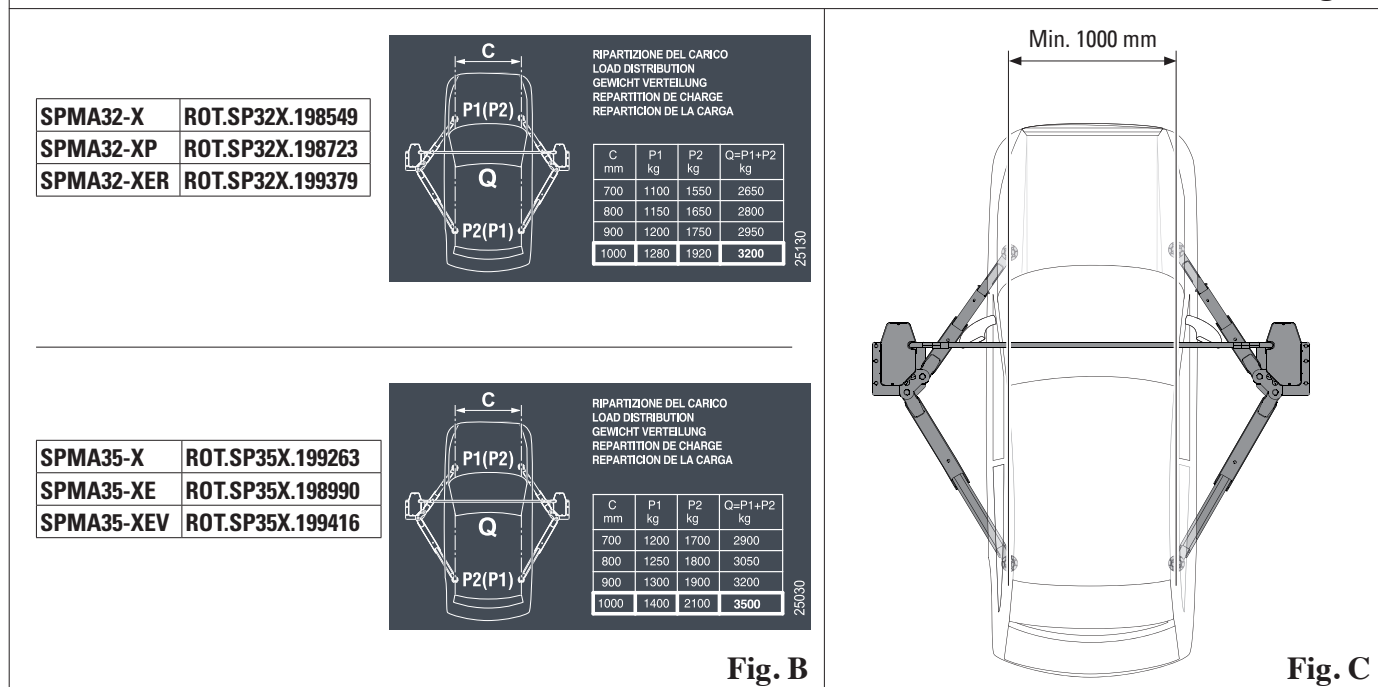
Fig. A

Fig. B
Fig. C

CHAP. 3 DONNEES TECHNIQUES**3.1 PRINCIPALES CARACTÉRISTIQUES TECHNIQUES**

Translation des chariots sur des patins en technopolymère à haute résistance et faible coefficient de frottement.

Mouvements de levage et d'abaissement obtenus au moyen d'écrous porteurs en bronze couplés à des vis de manœuvre à pas fin pour garantir l'irréversibilité des mouvements.

Dispositif de sécurité électronique empêchant toute course de levage supplémentaire en cas d'usure complète de l'écrou porteur.

Lubrification automatique des vis de manœuvre à chaque course.

Réalignement des chariots réalisé par un dispositif électronique.

Dispositif de verrouillage en cas de désalignement des chariots supérieur à 30 mm.

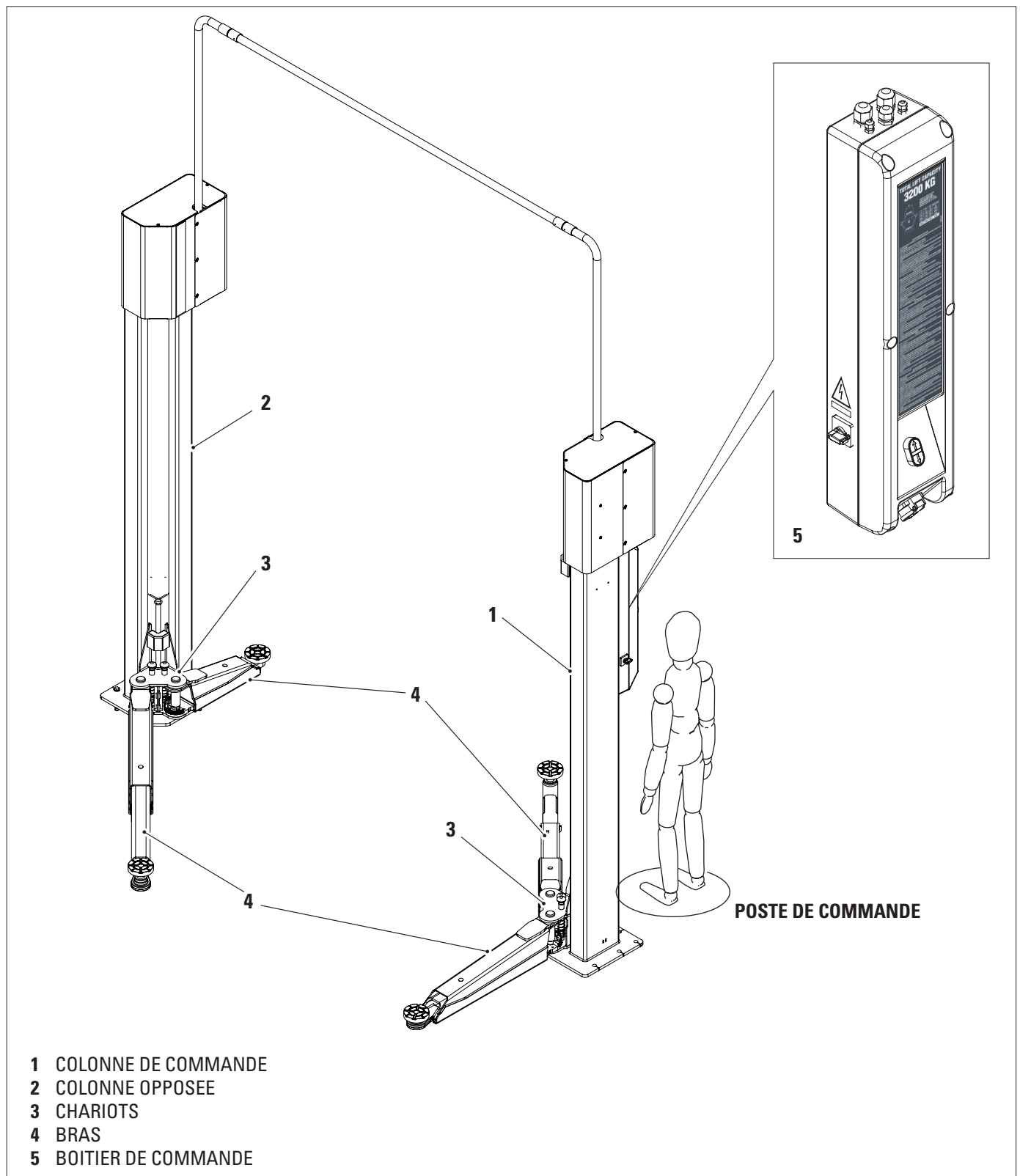

3.2 DÉTAILS TECHNIQUES GÉNÉRAUX
SPMA32

Nombre de colonnes	2	Bras avant min.	555 mm	Hauteur maximale de levage	2000 mm
Capacité de levage	3200 kg	Bras avant max.	1100 mm	Cale	1860 mm
Hauteur minimale du plafond	4150 mm	Bras arrière min.	805 mm	Temps de montée/descente	42 secs.
A Hauteur totale	4052 mm	Bras arrière max.	1200 mm	Alimentation	400 V 50 Hz 3Ph
B Colonnes externes	3223 mm	E Hauteur maximale des tampons	130 mm	Puissance d'entraînement	2x2.6 Kw
C Colonnes internes	2700 mm	F Hauteur minimale des tampons	96 mm		
D Passage	2472 mm				

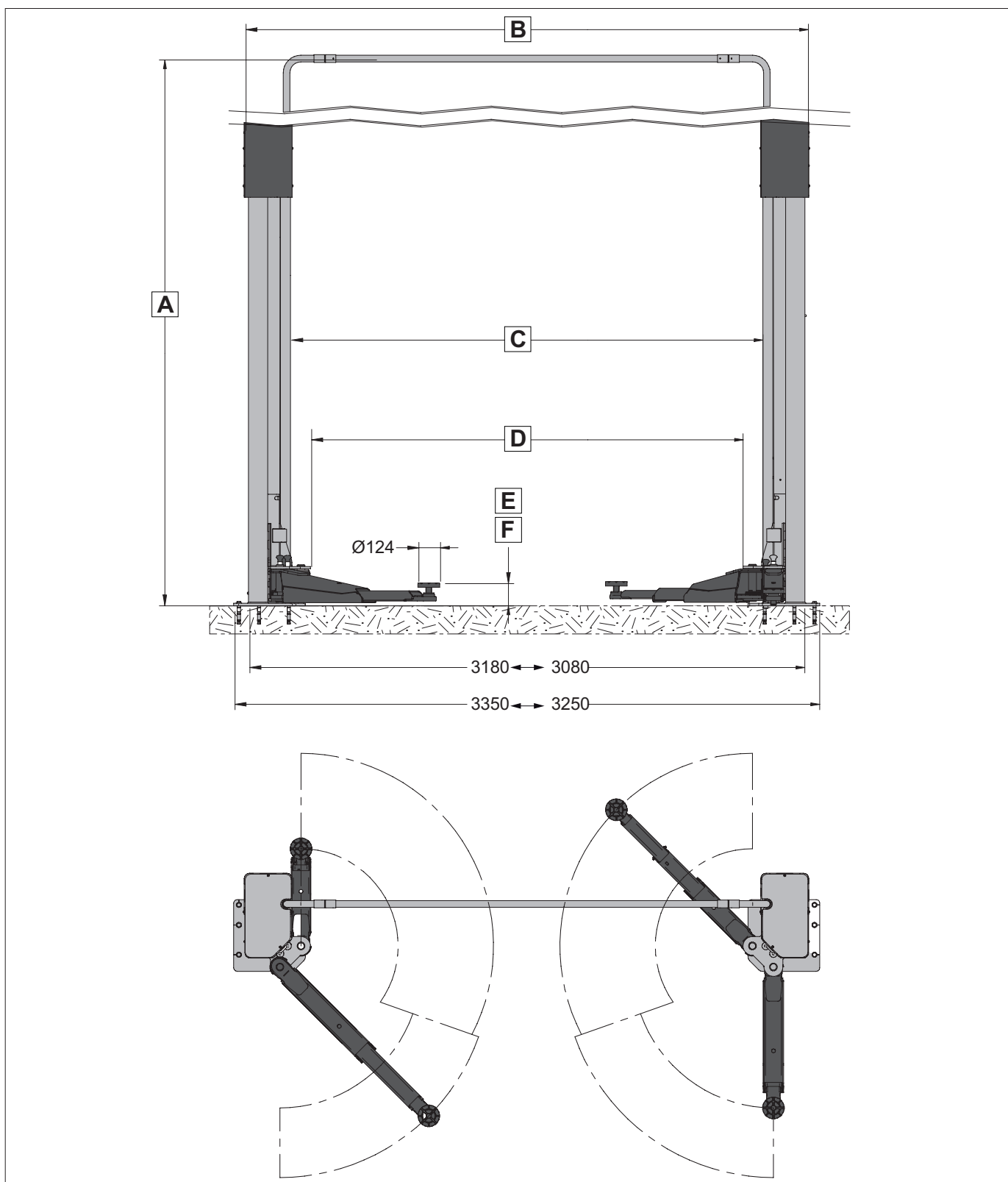

SPMA35

Nombre de colonnes	2	Bras avant min.	564 mm	Hauteur maximale de levage	2012 mm
Capacité de levage	3500 kg	Bras avant max.	1160 mm	Cale	1863 mm
Hauteur minimale du plafond	4150 mm	Bras arrière min.	922 mm	Temps de montée/descente	42 secs.
A Hauteur totale	4052 mm	Bras arrière max.	1460 mm	Alimentation	400 V 50 Hz 3Ph
B Colonnes externes	3223 mm	E Hauteur maximale des tampons	150 mm	Puissance d'entraînement	2x2.6 Kw
C Colonnes internes	2700 mm	F Hauteur minimale des tampons	100 mm		
D Passage	2472 mm				

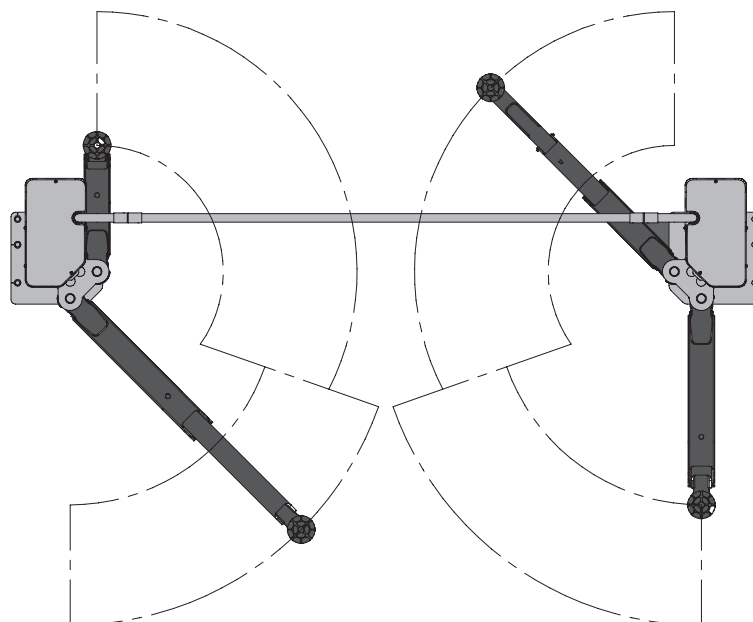
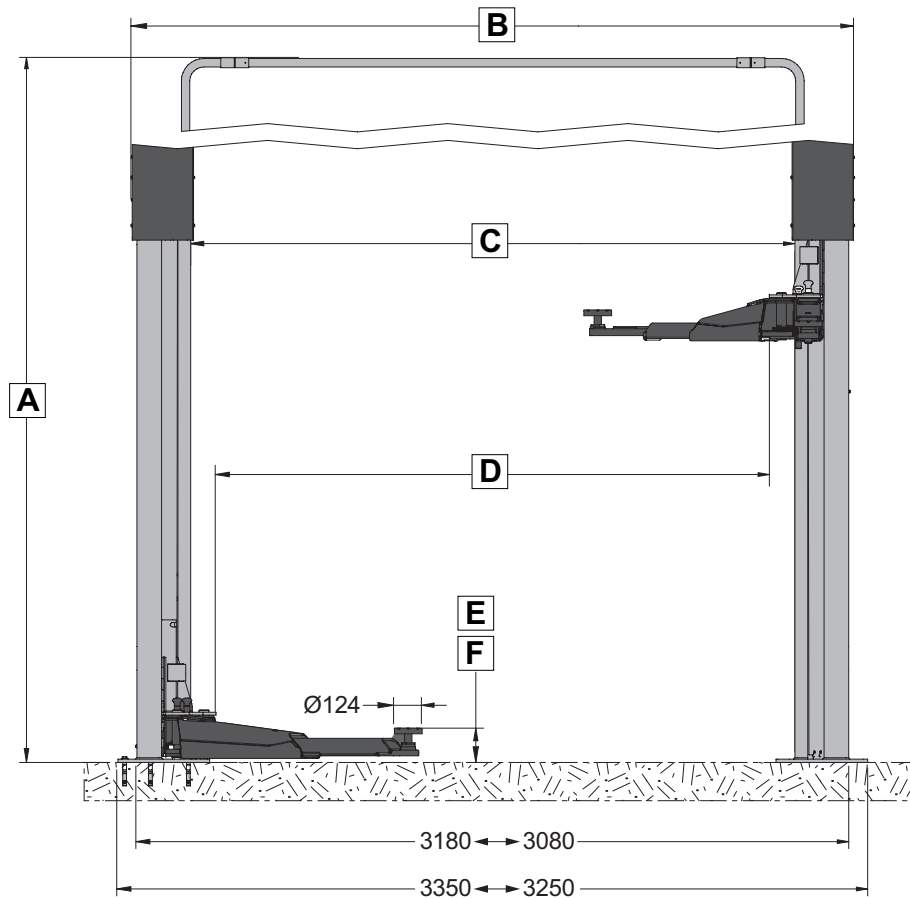

DONNÉES PHONOMÉTRIQUES
BRUIT

	Réf	Distance (m)	Lp dB(A)	Lpk dB(C)	U dB
	1	0,6	I 70dB(A)	I 130dB(C)	
2	1,0	73	I 130dB(C)		

3.3 DONNÉES D'IDENTIFICATION DE LA MACHINE

Le chariot de la colonne de commande porte la plaque d'identification de l'élèveur, sur laquelle figurent les données suivantes :

- A** Fabricant
- B** Portée pont élèveur
- C** Numéro matricule
- D** Année de construction
- E** Modèle

ATTENTION: Il est strictement interdit de falsifier, de graver, de modifier de quelque façon que ce soit ou d'enlever la plaque d'identification de la machine. Ne pas recouvrir la plaque au moyen de panneaux provisoires etc..., car elle doit toujours être bien visible.

La conserver toujours bien propre, exempte de graisse et de saleté en général.

PRECAUTION: si la plaque d'identification devait s'abîmer accidentellement (se détacher de la machine, s'endommager ou devenir illisible), en informer immédiatement le fabricant.

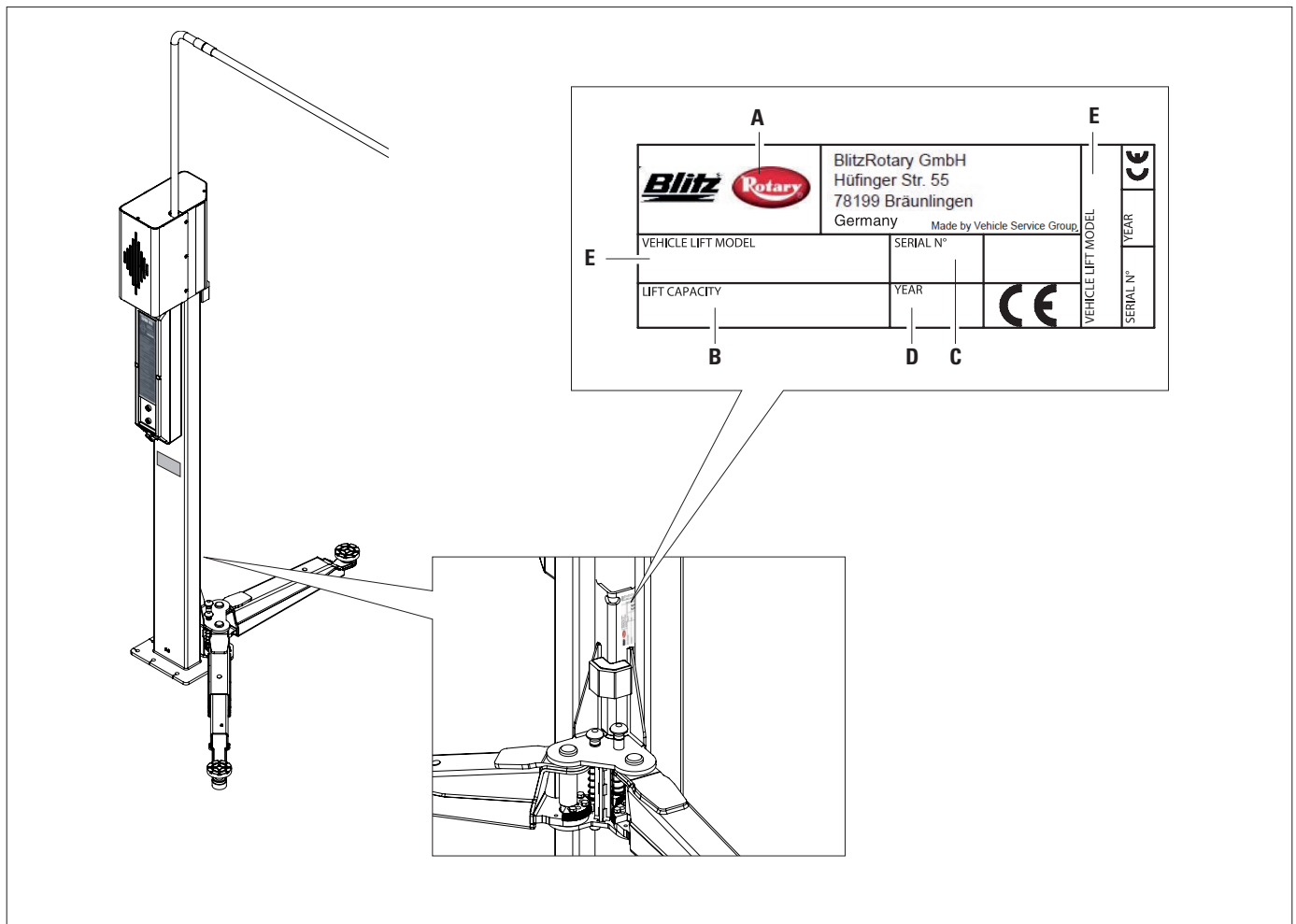

3.4 COMMANDES PRINCIPALES DE L'ÉLEVATEUR

Les commandes principales sont situées dans le boîtier de commande, qui change selon le modèle. Voir schéma de comparaison.

MODÈLE	CODE PN	CODE BOÎTIER DE COMMANDE	CODE BOÎTE DE DÉRIVATION	CODE INSTALLATION ÉLECTRIQUE
SPMA32-X	ROT.SP32X.198549	047303060	047303021	047305510
SPMA32-XP	ROT.SP32X.198723	047303070	047303080 (scatola comando)	047305530
SPMA32-XER	ROT.SP32X.199379	047303070	047303080 (scatola comando)	047305530
SPMA35-X	ROT.SP35X.199263	047303060	047303021	047305510
SPMA35-XE	ROT.SP35X.198990	047303070	047303080 (scatola comando)	047305530
SPMA35-XEV	ROT.SP35X.199416	047303070	047303080 (scatola comando)	047305530

047303060

Boîtier de commande avec interrupteur et boutons montée/descente.

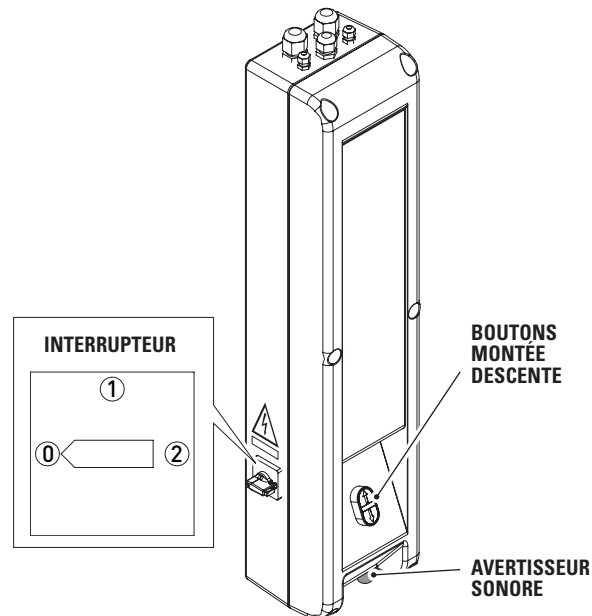
047303070 / 047303080

Double boîtier de commande avec interrupteur, boutons montée/descente, bouton d'urgence.

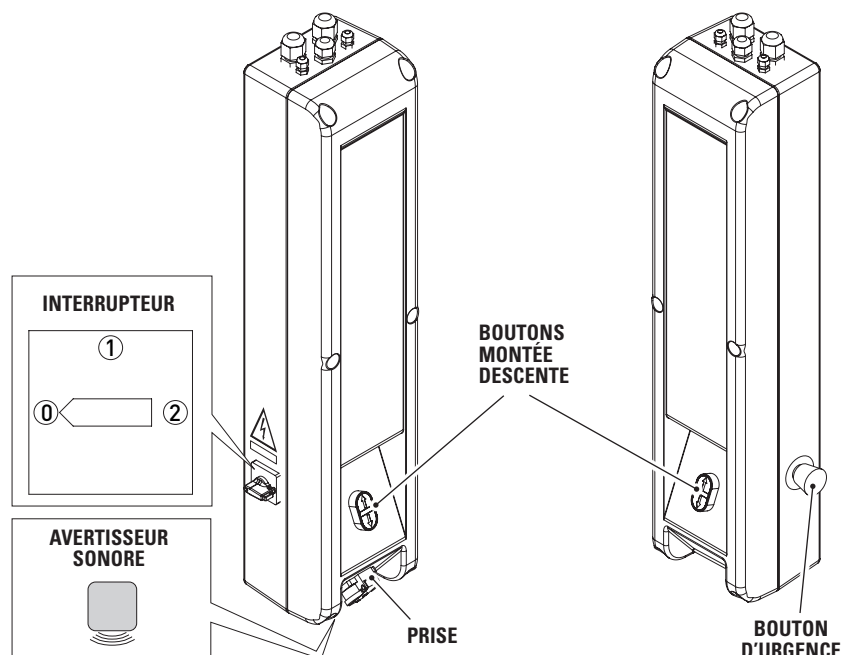

3.5. INSTALLATION ÉLECTRIQUE

L'installation doit être effectuée par l'utilisateur

CODE INSTALLATION ÉLECTRIQUE: 047305510

Alimentation électrique

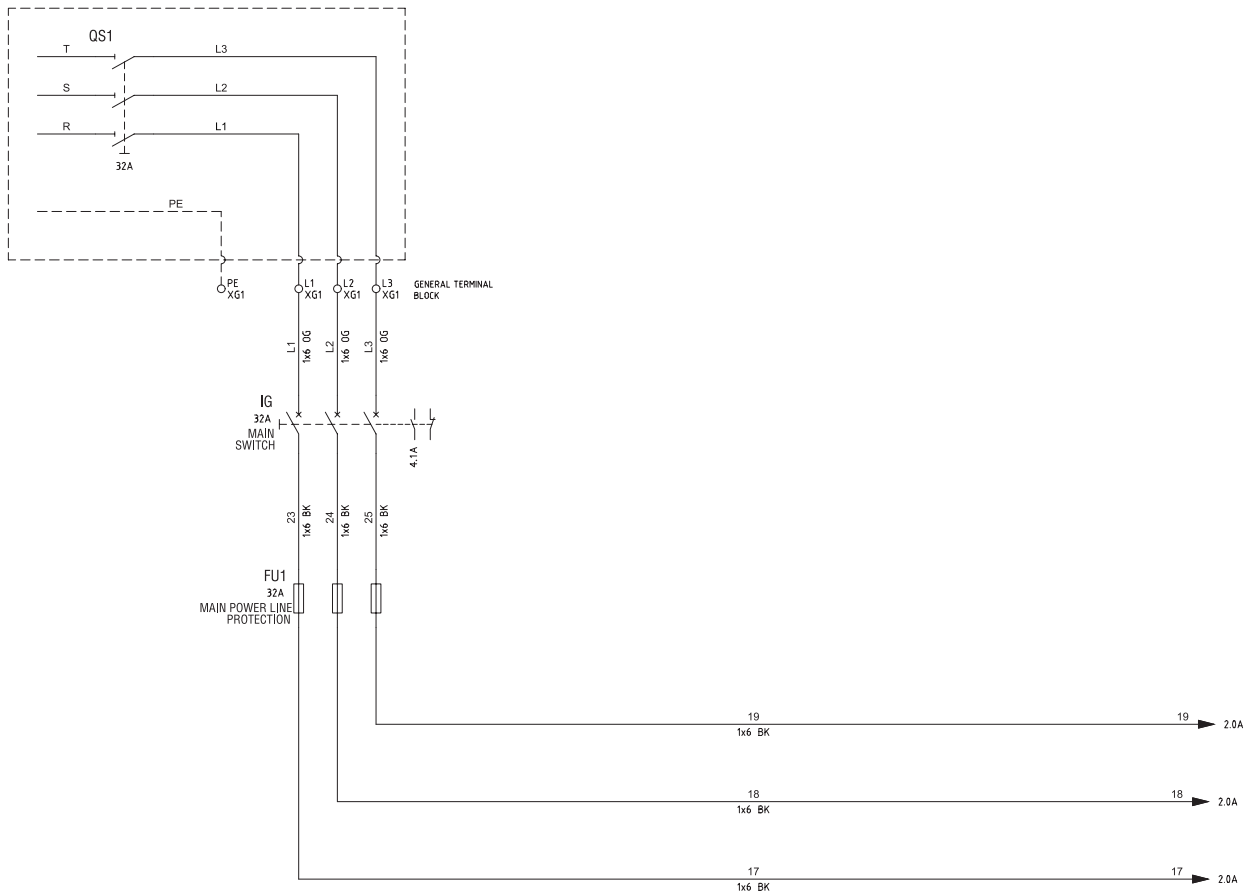

Alimentation moteur

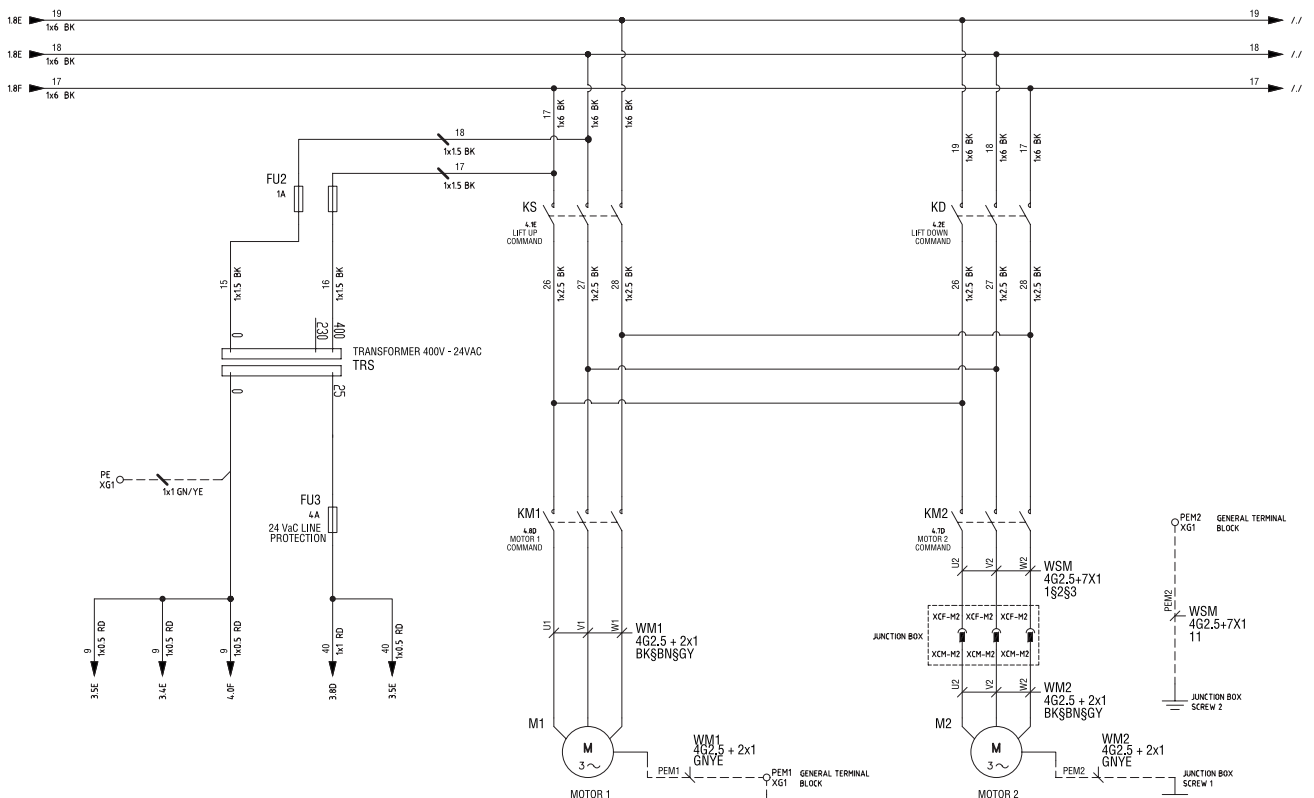

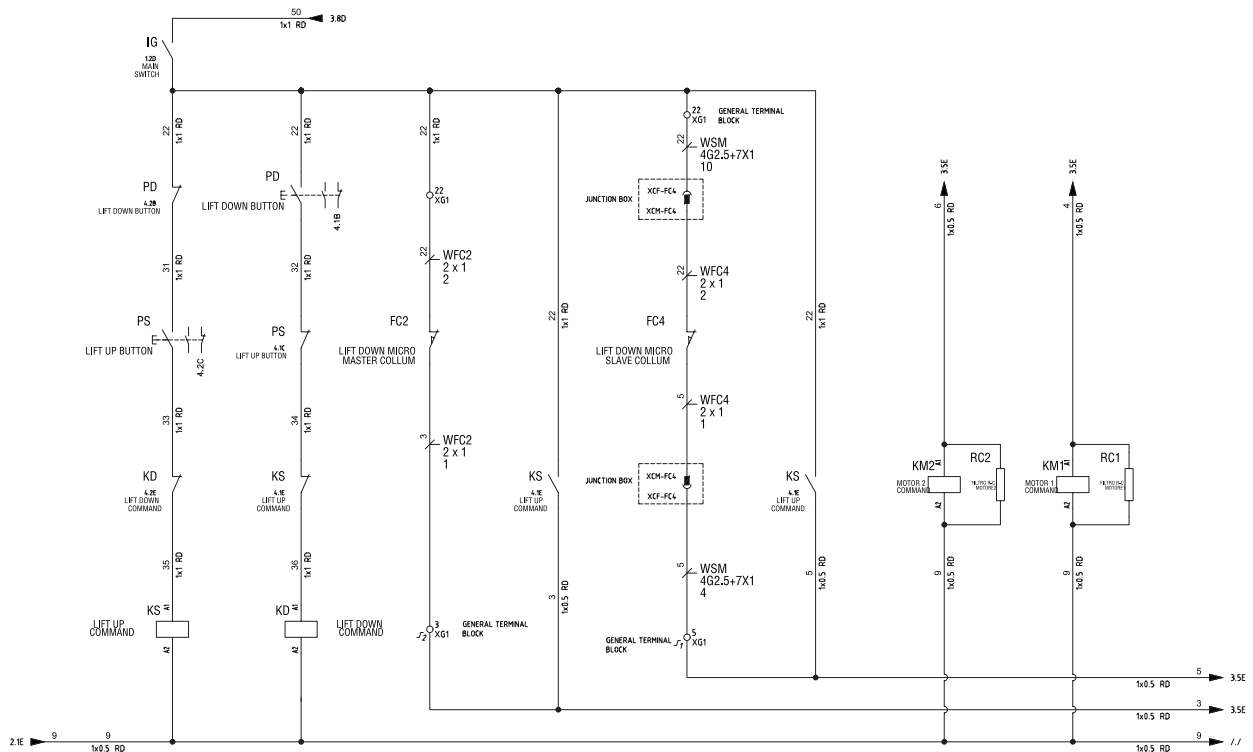
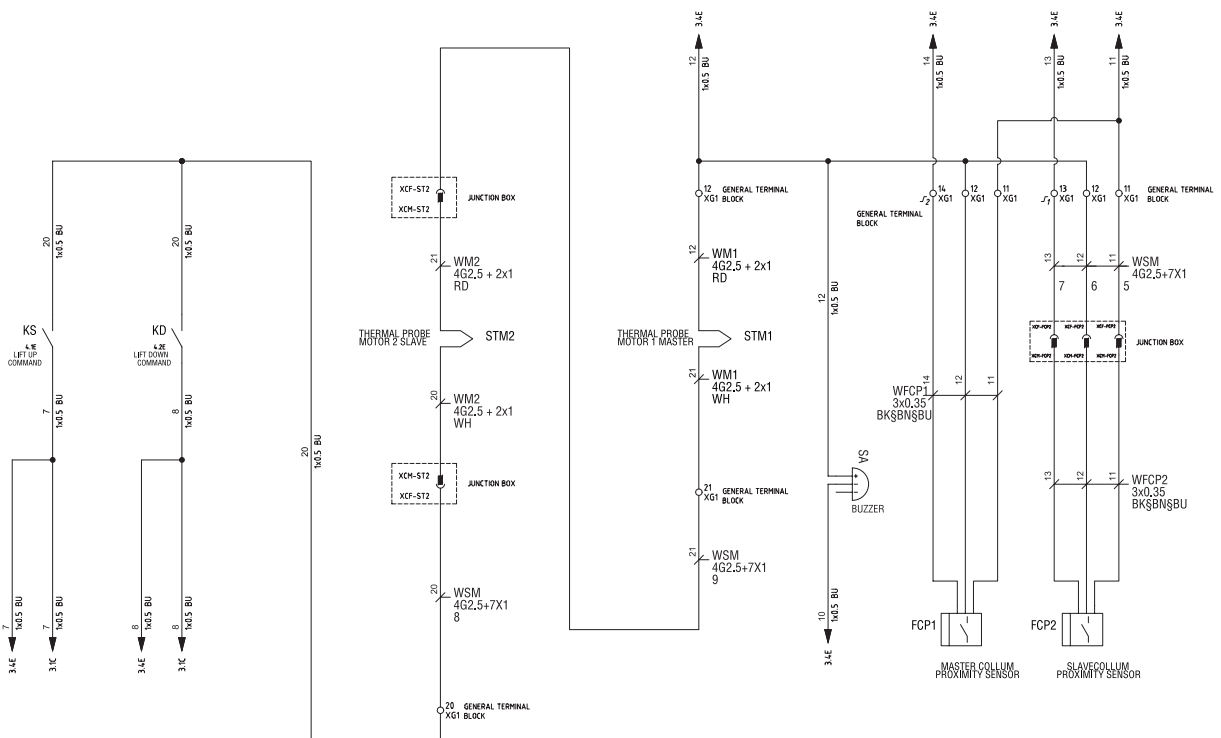
CODE INSTALLATION ÉLECTRIQUE: 047305510
Signaux de commande

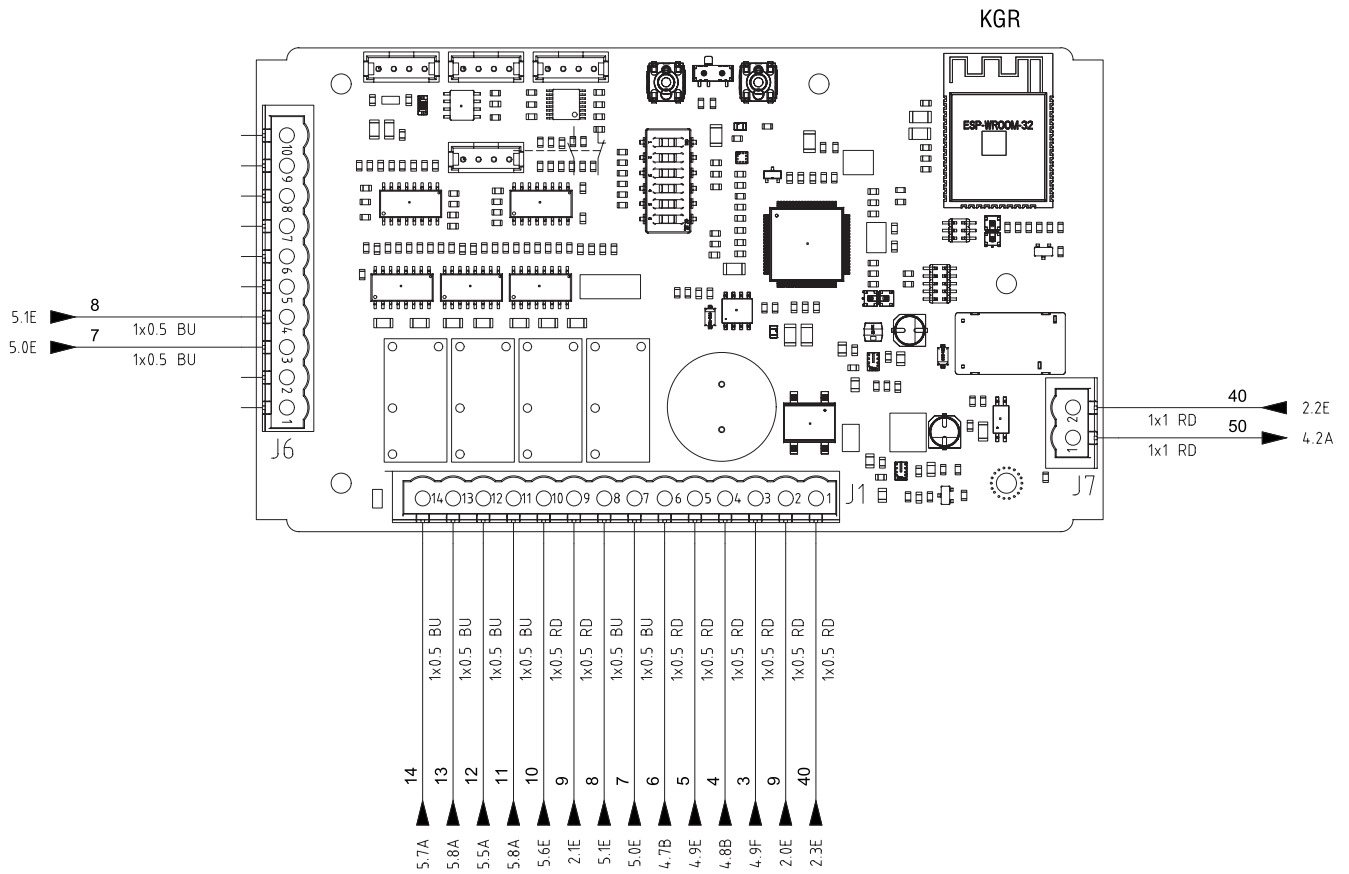
Signaux

CODE INSTALLATION ÉLECTRIQUE: 047305510
Signaux carte électronique

CODE INSTALLATION ÉLECTRIQUE: 047305510
Légende

LISTA CROSS REFERENCE \ CROSS REFERENCE LIST							
Componente	Reference	Dati Tecnici	Technical Data	Componente	Reference	Dati Tecnici	Technical Data
		Nome\Item:M1	Quadro\Panel: +BM Fg.\Sh:2			Nome\Item:FU3	Quadro\Panel: +QG Fg.\Sh:2
		Tipo \ Type : Costruttore \ Marke: Descrizione \ Device: Funzione \ Use Type:	Motore asincrono trifase MOTOR 1 COMMAND COLLUM			Tipo \ Type : Costruttore \ Marke: Descrizione \ Device: Funzione \ Use Type:	PORTAFUSIBILE UNIPOLARE 1A 5X20 250V 24 Vac LINE PROTECTION
		Nome\Item:M2	Quadro\Panel: +BM Fg.\Sh:2			Nome\Item:IG	Quadro\Panel: +QG Fg.\Sh:1
		Tipo \ Type : Costruttore \ Marke: Descrizione \ Device: Funzione \ Use Type:	Motore asincrono trifase MOTOR 2 SLAVE COLLUM			Tipo \ Type : Costruttore \ Marke: Descrizione \ Device: Funzione \ Use Type:	INTERRUTTORE GENERALE 4 POLI + AUX, 32A MAIN SWITCH
		Nome\Item:FC2	Quadro\Panel: +BM Fg.\Sh:4			Nome\Item:KD	Quadro\Board: +QG Fg.\Sh:4
		Tipo \ Type : Costruttore \ Marke: Descrizione \ Device: Funzione \ Use Type:	Fine corsa NC LIFT DOWN MICRO MASTER COLLUM			Tipo \ Type : Costruttore \ Marke: Descrizione \ Device: Funzione \ Use Type:	TELERUTTORE COMADO DISCESA LIFT DOWN COMMAND
		Nome\Item:FC4	Quadro\Panel: +BM Fg.\Sh:4			Nome\Item:KM1	Quadro\Panel: +QG Fg.\Sh:4
		Tipo \ Type : Costruttore \ Marke: Descrizione \ Device: Funzione \ Use Type:	Fine corsa NC LIFT DOWN MICRO SLAVE COLLUM			Tipo \ Type : Costruttore \ Marke: Descrizione \ Device: Funzione \ Use Type:	TELERUTTORE COMANDO MOTORE 1 MOTOR 1 COMMAND
		Nome\Item:FU1	Quadro\Panel: +QG Fg.\Sh:1			Nome\Item:KM2	Quadro\Panel: +QG Fg.\Sh:4
		Tipo \ Type : Costruttore \ Marke: Descrizione \ Device: Funzione \ Use Type:	PORTAFUS, TRIPOLARE 10X38 WIMEX 32A 500V MAIN POWER LINE PROTECTION			Tipo \ Type : Costruttore \ Marke: Descrizione \ Device: Funzione \ Use Type:	TELERUTTORE COMANDO MOTORE 2 MOTOR 2 COMMAND
		Nome\Item:FU2	Quadro\Panel: +QG Fg.\Sh:2			Nome\Item:KS	Quadro\Panel: +QG Fg.\Sh:4
		Tipo \ Type : Costruttore \ Marke: Descrizione \ Device: Funzione \ Use Type:	PORTAFUS, BIPOLARE 10X38 WIMEX 1A 500V TRANSFORMER POWER LINE PROTECTION			Tipo \ Type : Costruttore \ Marke: Descrizione \ Device: Funzione \ Use Type:	TELERUTTORE COMANDO SALITA LIFT UP COMMAND

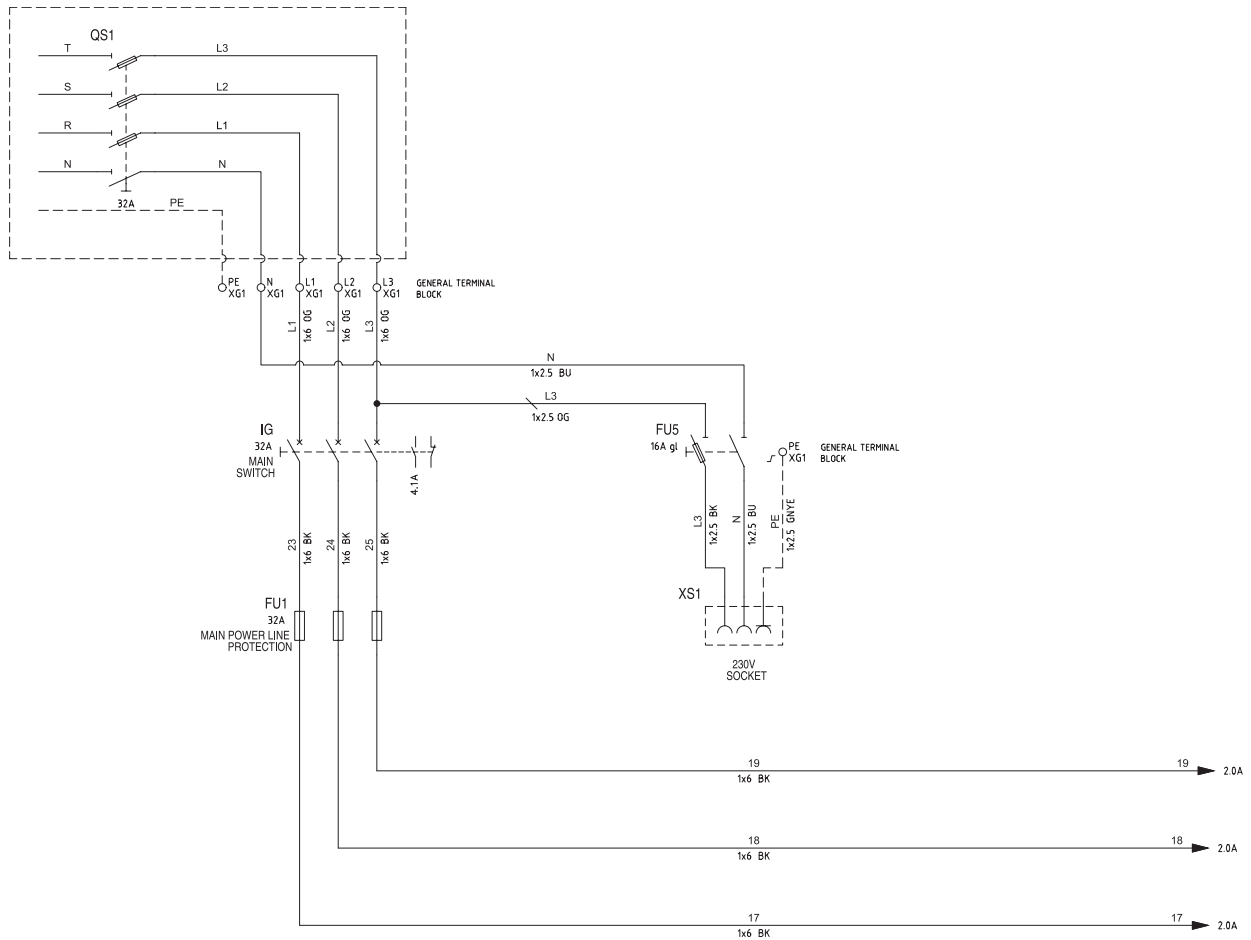
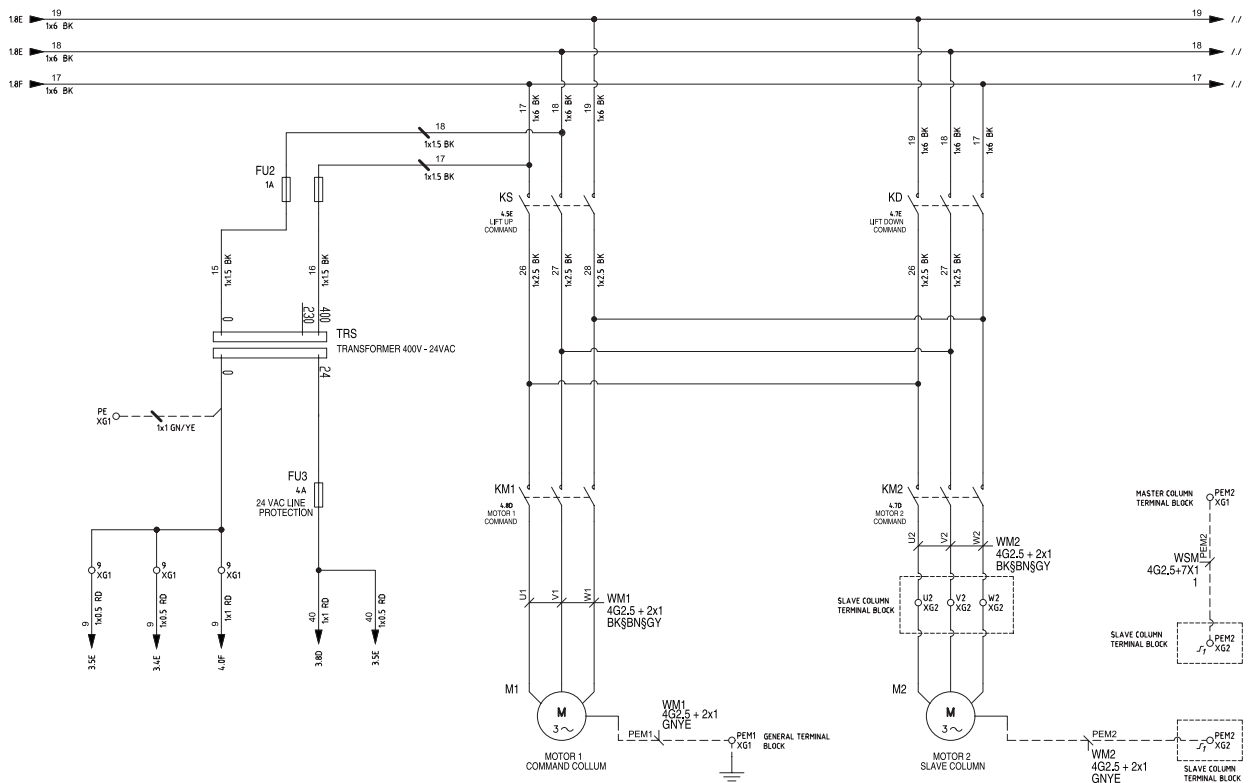
LISTA CROSS REFERENCE \ CROSS REFERENCE LIST							
Componente	Reference	Dati Tecnici	Technical Data	Componente	Reference	Dati Tecnici	Technical Data
		Nome\Item:PD	Quadro\Panel: +QG Fg.\Sh:4			Nome\Item:FCP1	Quadro\Panel: +BM Fg.\Sh:5
		Tipo \ Type : Costruttore \ Marke: Descrizione \ Device: Funzione \ Use Type:	PULSANTE DISCESA LIFT DOWN BUTTON			Tipo \ Type : Costruttore \ Marke: Descrizione \ Device: Funzione \ Use Type:	INTERRUTTORE DI PROSSIMITA' PROXIMITY SENSOR
		Nome\Item:PS	Quadro\Panel: +QG Fg.\Sh:4			Nome\Item:FCP2	Quadro\Panel: +BM Fg.\Sh:5
		Tipo \ Type : Costruttore \ Marke: Descrizione \ Device: Funzione \ Use Type:	PULSANTE DISCESA LIFT UP BUTTON			Tipo \ Type : Costruttore \ Marke: Descrizione \ Device: Funzione \ Use Type:	INTERRUTTORE DI PROSSIMITA' PROXIMITY SENSOR
		Nome\Item:QS1	Quadro\Panel: +QG Fg.\Sh:1			Nome\Item:KGR	Quadro\Board: +QG Fg.\Sh:3
		Tipo \ Type : Costruttore \ Marke: Descrizione \ Device: Funzione \ Use Type:	INTERRUTTORE GENERALE CLIENTE 32A CLIENT POWER MAIN SWITCH			Tipo \ Type : Costruttore \ Marke: Descrizione \ Device: Funzione \ Use Type:	SCHEDA ELETTRONICA ELECTRONIC BOARD
		Nome\Item:RC1	Quadro\Panel: +QG Fg.\Sh:4			Nome\Item:STM1	Quadro\Panel: +BM Fg.\Sh:5
		Tipo \ Type : Costruttore \ Marke: Descrizione \ Device: Funzione \ Use Type:	FILTRO ANTIDISTURBI R-C MOTORE1			Tipo \ Type : Costruttore \ Marke: Descrizione \ Device: Funzione \ Use Type:	SONDA TERMICA THERMAL PROBE MOTOR 1 MASTER
		Nome\Item:RC2	Quadro\Panel: +QG Fg.\Sh:4			Nome\Item:STM2	Quadro\Panel: +BM Fg.\Sh:5
		Tipo \ Type : Costruttore \ Marke: Descrizione \ Device: Funzione \ Use Type:	FILTRO ANTIDISTURBI R-C MOTORE2			Tipo \ Type : Costruttore \ Marke: Descrizione \ Device: Funzione \ Use Type:	SONDA TERMICA THERMAL PROBE MOTOR 2 SLAVE
		Nome\Item:SA	Quadro\Panel: +QG Fg.\Sh:5			Nome\Item:TRS	Quadro\Panel: +QG Fg.\Sh:2
		Tipo \ Type : Costruttore \ Marke: Descrizione \ Device: Funzione \ Use Type:	AVVISATORE ACUSTICO BUZZER			Tipo \ Type : Costruttore \ Marke: Descrizione \ Device: Funzione \ Use Type:	TRASFORMATORE 100 V/A TRANSFORMER 400V - 24VAC

CODE INSTALLATION ÉLECTRIQUE: 047305530
Alimentation électrique

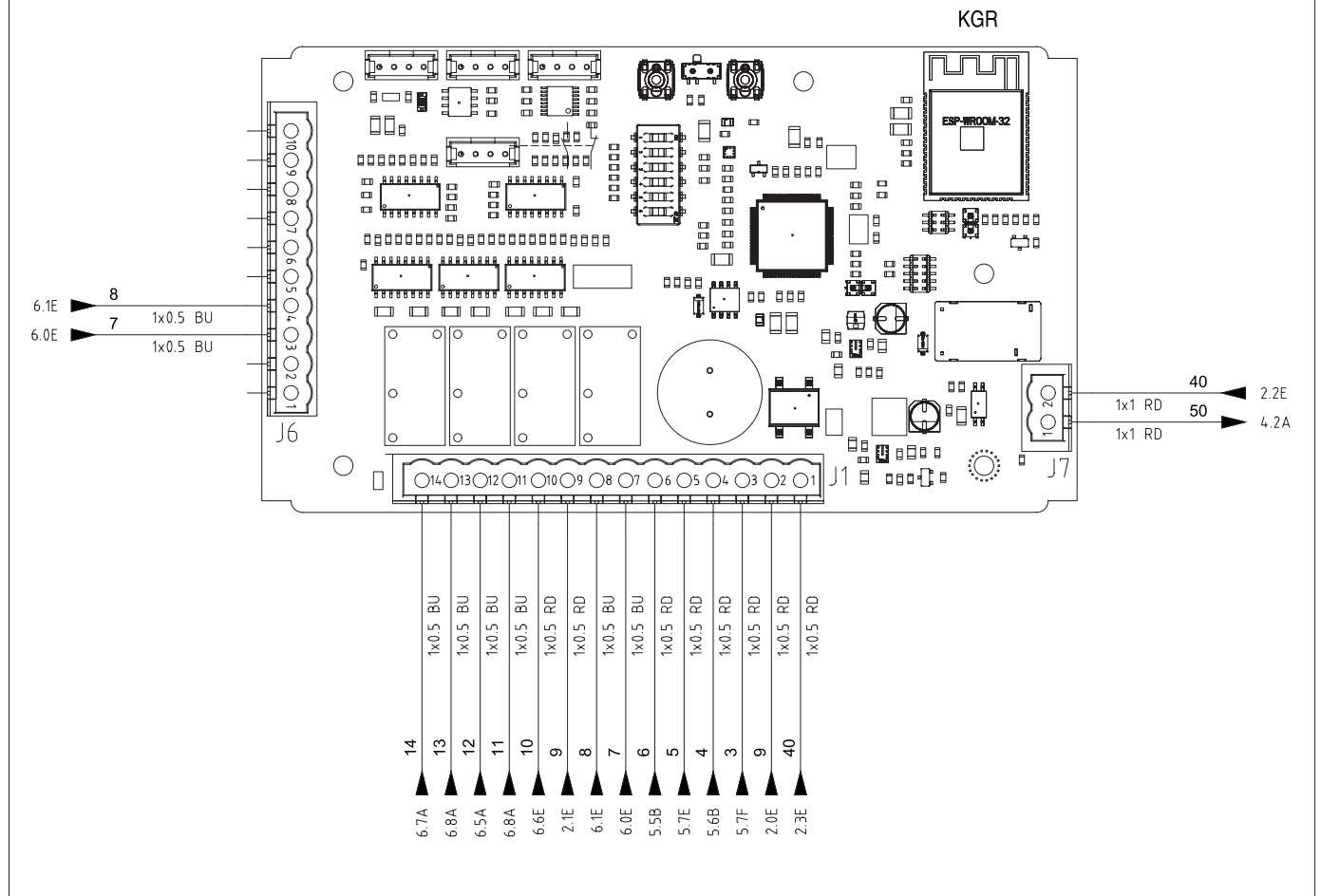
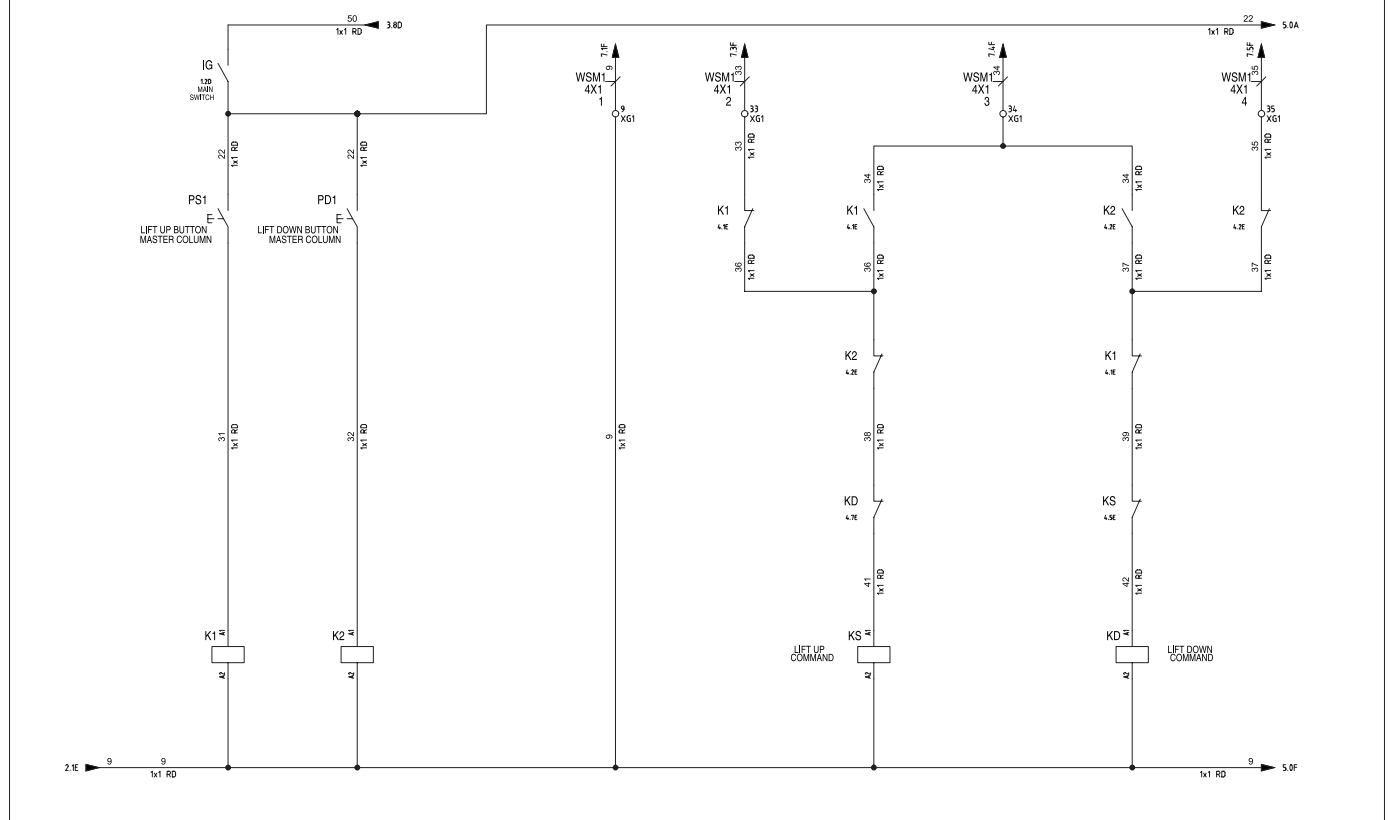
Alimentation moteur

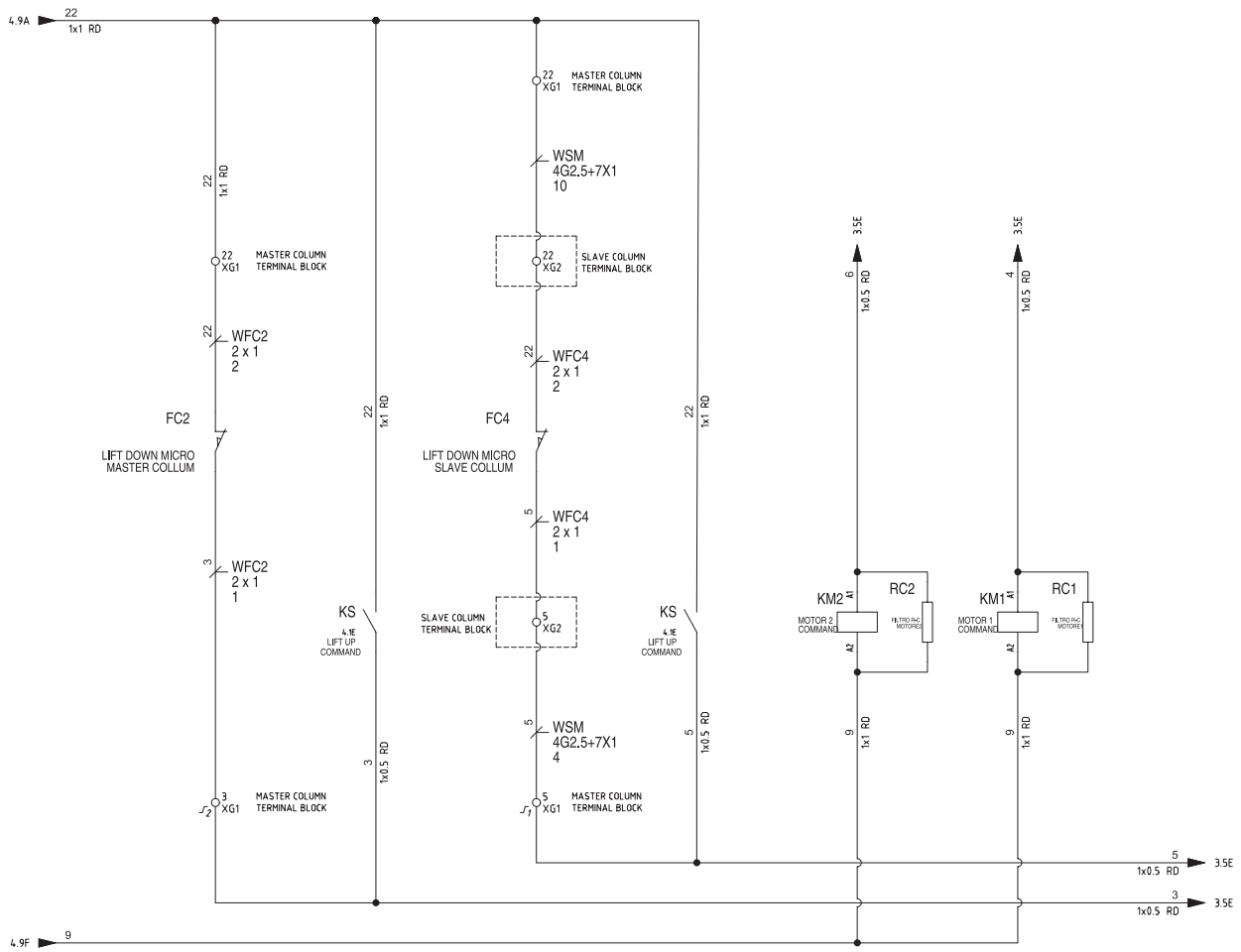
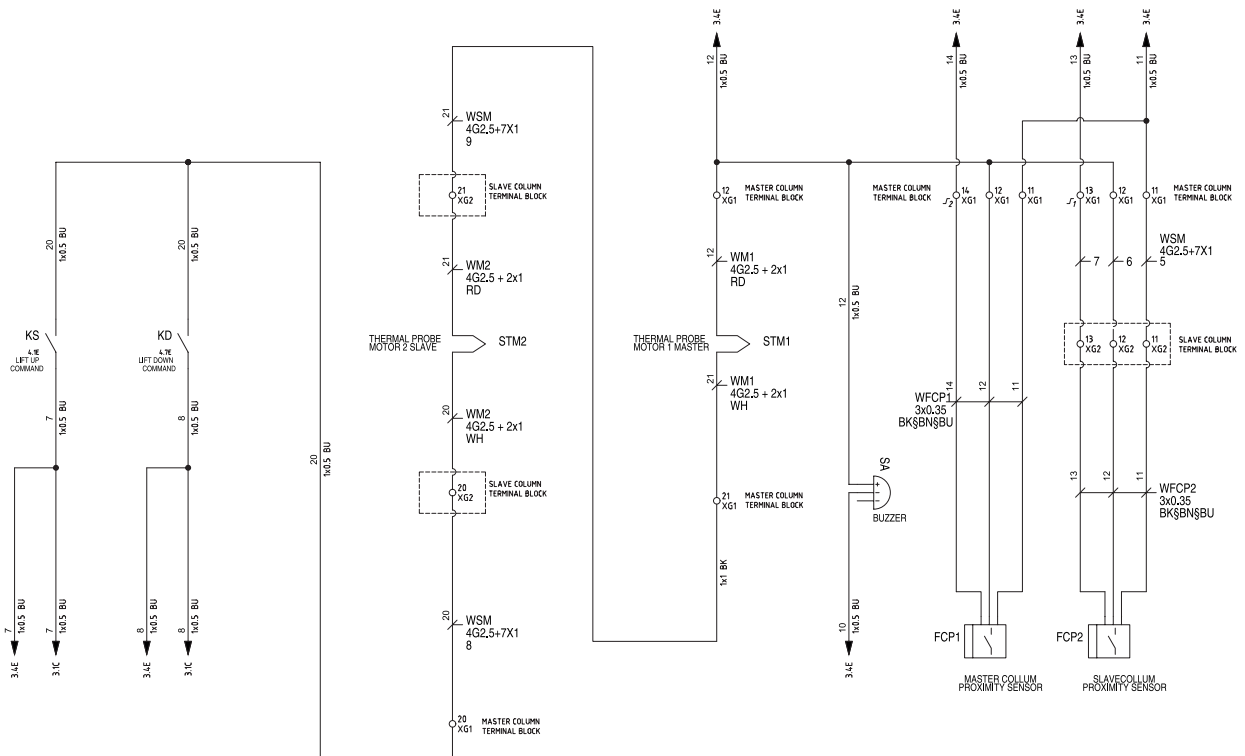
CODE INSTALLATION ÉLECTRIQUE: 047305530
Signaux carte électronique

Signaux de commande

CODE INSTALLATION ÉLECTRIQUE: 047305530
Signaux

Signaux

CODE INSTALLATION ÉLECTRIQUE: 047305530
Légende

LISTA CROSS REFERENCE \ CROSS REFERENCE LIST							
Componente	Reference	Dati Tecnici	Technical Data	Componente	Reference	Dati Tecnici	Technical Data
		Nome\Item:M1	Quadro\Panel: +BM Fg.\Sh.:2			Nome\Item:FU3	Quadro\Panel: +QG Fg.\Sh.:2
		Tipo \ Type : Costruttore \ Marke: Descrizione \ Device : Motore asincrono trifase Funzione \ Use Type : MOTOR 1 COMMAND COLLUM				Tipo \ Type : Costruttore \ Marke: Descrizione \ Device : PORTAFUSIBILE UNIPOLARE 1A 5X20 250V Funzione \ Use Type : 24 VaC LINE PROTECTION	
		Nome\Item:M2	Quadro\Panel: +BM Fg.\Sh.:2			Nome\Item:IG	Quadro\Panel: +QG Fg.\Sh.:1
		Tipo \ Type : Costruttore \ Marke: Descrizione \ Device : Motore asincrono trifase Funzione \ Use Type : SLAVE COLUMN				Tipo \ Type : Costruttore \ Marke: Descrizione \ Device : INTERRUTTORE GENERALE 4 POLI + AUX. 32A Funzione \ Use Type : MAIN SWITCH	
		Nome\Item:FC2	Quadro\Panel: +BM Fg.\Sh.:4			Nome\Item:KD	Quadro\Board: +QG Fg.\Sh.:4
		Tipo \ Type : Costruttore \ Marke: Descrizione \ Device : Fine corsa NC Funzione \ Use Type : LIFT DOWN MICRO MASTER COLLUM				Tipo \ Type : Costruttore \ Marke: Descrizione \ Device : TELERUTTORE COMADO DISCESA Funzione \ Use Type : LIFT DOWN COMMAND	
		Nome\Item:FC4	Quadro\Panel: +BM Fg.\Sh.:4			Nome\Item:KM1	Quadro\Panel: +QG Fg.\Sh.:4
		Tipo \ Type : Costruttore \ Marke: Descrizione \ Device : Fine corsa NC Funzione \ Use Type : LIFT DOWN MICRO SLAVE COLLUM				Tipo \ Type : Costruttore \ Marke: Descrizione \ Device : TELERUTTORE COMANDO MOTORE 1 Funzione \ Use Type : MOTOR 1 COMMAND	
		Nome\Item:FU1	Quadro\Panel: +QG Fg.\Sh.:1			Nome\Item:KM2	Quadro\Panel: +QG Fg.\Sh.:4
		Tipo \ Type : Costruttore \ Marke: Descrizione \ Device : PORTAFUS. TRIPOLARE 10X38 WIMEX 32A 500V Funzione \ Use Type : MAIN POWER LINE PROTECTION				Tipo \ Type : Costruttore \ Marke: Descrizione \ Device : TELERUTTORE COMANDO MOTORE 2 Funzione \ Use Type : MOTOR 2 COMMAND	
		Nome\Item:FU2	Quadro\Panel: +QG Fg.\Sh.:2			Nome\Item:KS	Quadro\Panel: +QG Fg.\Sh.:4
		Tipo \ Type : Costruttore \ Marke: Descrizione \ Device : PORTAFUS. BIPOLARE 10X38 WIMEX 1A 500V Funzione \ Use Type : TRANSFORMER POWER LINE PROTECTION				Tipo \ Type : Costruttore \ Marke: Descrizione \ Device : TELERUTTORE COMANDO SALITA Funzione \ Use Type : LIFT UP COMMAND	

LISTA CROSS REFERENCE \ CROSS REFERENCE LIST							
Componente	Reference	Dati Tecnici	Technical Data	Componente	Reference	Dati Tecnici	Technical Data
		Nome\Item:PD	Quadro\Panel: +QG Fg.\Sh.:4			Nome\Item:FCP1	Quadro\Panel: +BM Fg.\Sh.:5
		Tipo \ Type : Costruttore \ Marke: Descrizione \ Device : PULSANTE DISCESA Funzione \ Use Type : LIFT DOWN BUTTON				Tipo \ Type : Costruttore \ Marke: Descrizione \ Device : INTERRUTTORE DI PROSSIMITA' Funzione \ Use Type : PROXIMITY SENSOR	
		Nome\Item:PS	Quadro\Panel: +QG Fg.\Sh.:4			Nome\Item:FCP2	Quadro\Panel: +BM Fg.\Sh.:5
		Tipo \ Type : Costruttore \ Marke: Descrizione \ Device : PULSANTE DISCESA Funzione \ Use Type : LIFT UP BUTTON				Tipo \ Type : Costruttore \ Marke: Descrizione \ Device : INTERRUTTORE DI PROSSIMITA' Funzione \ Use Type : PROXIMITY SENSOR	
		Nome\Item:QS1	Quadro\Panel: +QG Fg.\Sh.:1			Nome\Item:KGR	Quadro\Board: +QG Fg.\Sh.:3
		Tipo \ Type : Costruttore \ Marke: Descrizione \ Device : INTERRUTTORE GENERALE CLIENTE 32A Funzione \ Use Type : CLIENT POWER MAIN SWITCH				Tipo \ Type : Costruttore \ Marke: Descrizione \ Device : SCHEDA ELETTRONICA Funzione \ Use Type : ELECTRONIC BOARD	
		Nome\Item:RC1	Quadro\Panel: +QG Fg.\Sh.:4			Nome\Item:STM1	Quadro\Panel: +BM Fg.\Sh.:5
		Tipo \ Type : Costruttore \ Marke: Descrizione \ Device : FILTRO ANTIDISTURBI R-C Funzione \ Use Type : MOTORE1				Tipo \ Type : Costruttore \ Marke: Descrizione \ Device : SONDA TERMICA Funzione \ Use Type : THERMAL PROBE MOTOR 1 MASTER	
		Nome\Item:RC2	Quadro\Panel: +QG Fg.\Sh.:4			Nome\Item:STM2	Quadro\Panel: +BM Fg.\Sh.:5
		Tipo \ Type : Costruttore \ Marke: Descrizione \ Device : FILTRO ANTIDISTURBI R-C Funzione \ Use Type : MOTORE2				Tipo \ Type : Costruttore \ Marke: Descrizione \ Device : SONDA TERMICA Funzione \ Use Type : THERMAL PROBE MOTOR 2 SLAVE	
		Nome\Item:SA	Quadro\Panel: +QG Fg.\Sh.:5			Nome\Item:TRS	Quadro\Panel: +QG Fg.\Sh.:2
		Tipo \ Type : Costruttore \ Marke: Descrizione \ Device : AVVISATORE ACUSTICO Funzione \ Use Type : BUZZER				Tipo \ Type : Costruttore \ Marke: Descrizione \ Device : TRASFORMATORE 100 V/A Funzione \ Use Type : TRANSFORMER 400V - 24VAC	
		Nome\Item: FU5	Quadro\Panel: +QG Fg.\Sh.:1			Nome\Item:	Quadro\Panel: Fg.\Sh.:
		Tipo \ Type : Costruttore \ Marke: Descrizione \ Device : Funzione \ Use Type :PROTEZIONE LINA 230V PRESA				Tipo \ Type : Costruttore \ Marke: Descrizione \ Device : Funzione \ Use Type :	
		Nome\Item: XS1	Quadro\Panel: +QG Fg.\Sh.:1			Nome\Item:	Quadro\Panel: Fg.\Sh.:
		Tipo \ Type : Costruttore \ Marke: Descrizione \ Device : PRESA 230V Funzione \ Use Type :				Tipo \ Type : Costruttore \ Marke: Descrizione \ Device : Funzione \ Use Type :	

CHAP. 4 NORMES GENERALES DE SECURITE



4.1 INFORMATIONS SUR LES RISQUES RESIDUELS

L'élévateur objet de la présente notice a été fabriqué dans le respect de normes sévères pour répondre aux qualités requises par les directives régissant ces appareils.

Une analyse attentive des risques a été réalisée et les dangers ont été éliminés dans la mesure du possible.

Les risques résiduels éventuels ont été signalés dans la présente notice et sur la machine au moyen de pictogrammes.

4.2 PLAQUES ET/OU AUTOCOLLANTS DE SECURITE

L'élévateur comporte des plaques et des autocollants concernant l'identification de la machine, la capacité de charge, les instructions et l'installation électrique.

Les pictogrammes endommagés doivent être remplacés. S'adresser directement à la Société ROTARY.

4.3 FORMATION DU PERSONNEL PREPOSE

L'utilisation de l'équipement n'est consentie qu'au personnel autorisé, possédant une formation adéquate.

Pour que la gestion de la machine soit optimale et que l'on puisse réaliser les opérations avec un maximum d'efficacité, il est indispensable que le personnel préposé suive une formation appropriée en mesure de fournir toutes les informations nécessaires permettant d'opérer en conformité avec les instructions fournies par le fabricant.

Pour tout doute concernant l'utilisation et l'entretien de la machine, consulter la notice d'instructions et, si nécessaire, s'adresser aux centres d'assistance technique agréés ou le Service Après-Vente ROTARY.

4.4 APTITUDE A L'EMPLOI

Ce produit a été fabriqué en conformité avec la Directive Européenne 2006/42/CE. En vertu de l'article 4.1.2.3. (Pièce Jointe 1) de la dite Directive, les coefficients adoptés pour les essais sont les suivants:

1,10 pour l'essai dynamique

1,25 pour l'essai statique.

Ces essais doivent être réalisés par un personnel spécialisé.

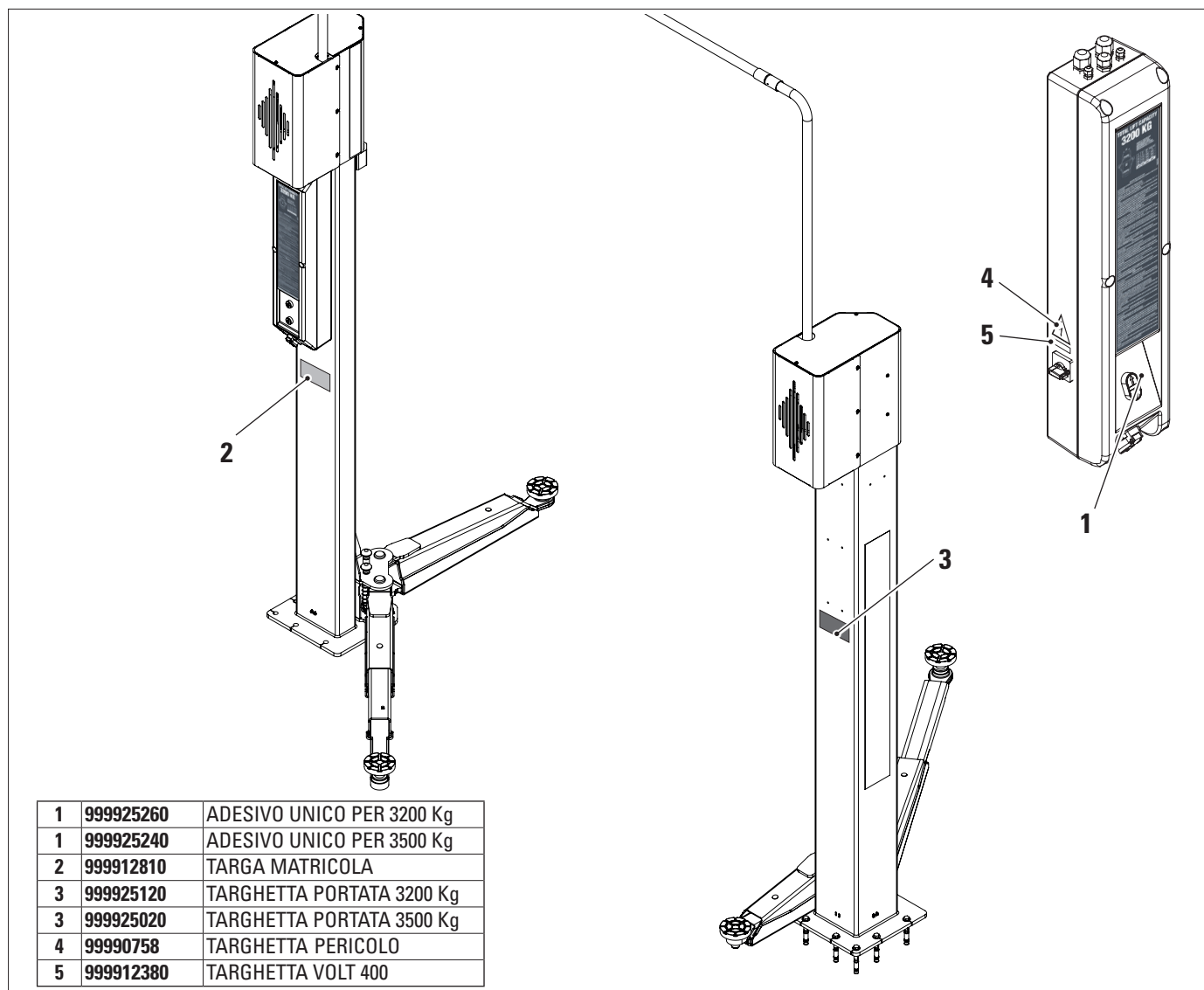

1	999925260	ADESIVO UNICO PER 3200 Kg
1	999925240	ADESIVO UNICO PER 3500 Kg
2	999912810	TARGA MATRICOLA
3	999925120	TARGHETTA PORTATA 3200 Kg
3	999925020	TARGHETTA PORTATA 3500 Kg
4	99990758	TARGHETTA PERICOLO
5	999912380	TARGHETTA VOLT 400

CHAP. 5 EXIGENCES D'INSTALLATION**5.1 CARACTERISTIQUES MINIMES REQUISES POUR LA ZONE D'INSTALLATION**

S'assurer que l'endroit où la machine doit être installée est conforme aux exigences suivantes :

- l'utilisation de l'élévateur n'est autorisée qu'à l'intérieur de locaux fermés, ne présentant aucun risque d'explosion ou d'incendie.
- l'élévateur ne convient pas pour une utilisation impliquant le lavage des véhicules.
- éclairage suffisant (mais endroit non soumis à l'éblouissement ou à une lumière intense). Référence à la norme UNI 10380 ;
- endroit non exposé aux intempéries ;
- endroit assurant un échange d'air adéquat ;
- environnement exempt de polluants ;
- niveau de bruit inférieur aux exigences réglementaires en vigueur à I 70 dB (A) ;
- température ambiante : min. 5° - max 55° ;
- le lieu de travail ne doit pas être exposé à des mouvements dangereux dus à d'autres machines en fonctionnement ;
- le local où est installée la machine ne doit pas être utilisé pour stocker des matériaux explosifs, corrosifs et/ou toxiques ;
- la distance entre les colonnes et les parois ou tout équipement fixe doit être d'au moins 50 cm ;
- choisir la disposition d'installation en tenant compte du fait que, depuis le poste de commande, l'opérateur doit pouvoir visualiser l'ensemble de l'appareil et la zone environnante. Il doit empêcher la présence de personnes non autorisées et d'objets pouvant constituer une source de danger dans cette zone.

Toutes les opérations d'installation relatives aux connexions à des sources d'alimentation externes (électriques en particulier) doivent être effectuées par du personnel professionnellement qualifié.

L'installation doit être effectuée par du personnel autorisé en suivant les éventuelles instructions spéciales de ce livret ; en cas de doute, consulter les centres d'assistance autorisés ou l'assistance technique ROTARY.

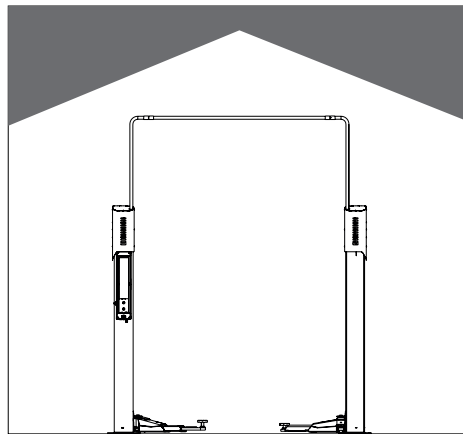
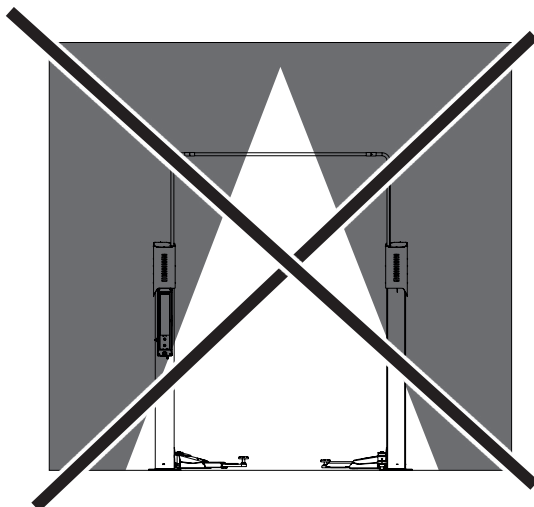
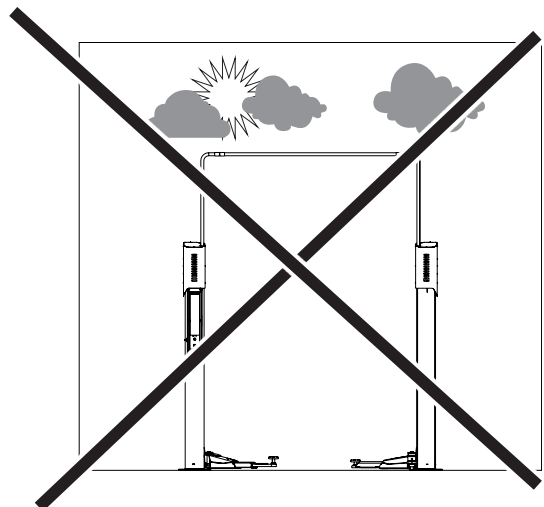
**OUI****NON****NON**

5.2 EXIGENCES EN MATIÈRE DE PLANCHER

L'élèveateur doit être installé sur un sol plat et horizontal capable de supporter les CHARGES TRANSMISES AU PLAN D'APPUI indiquées dans le tableau (fig. B). Caractéristiques minimales requises :

- a) Qualité du béton : min. C25/30
- b) Épaisseur minimale du sol : 160 mm (exempt de tout revêtement de sol et enduit de lissage associées) (*)

Il est conseillé de consulter un technicien qualifié pour savoir si l'installation convient.

(*) L'épaisseur minimale dépend du type de cheville utilisé.

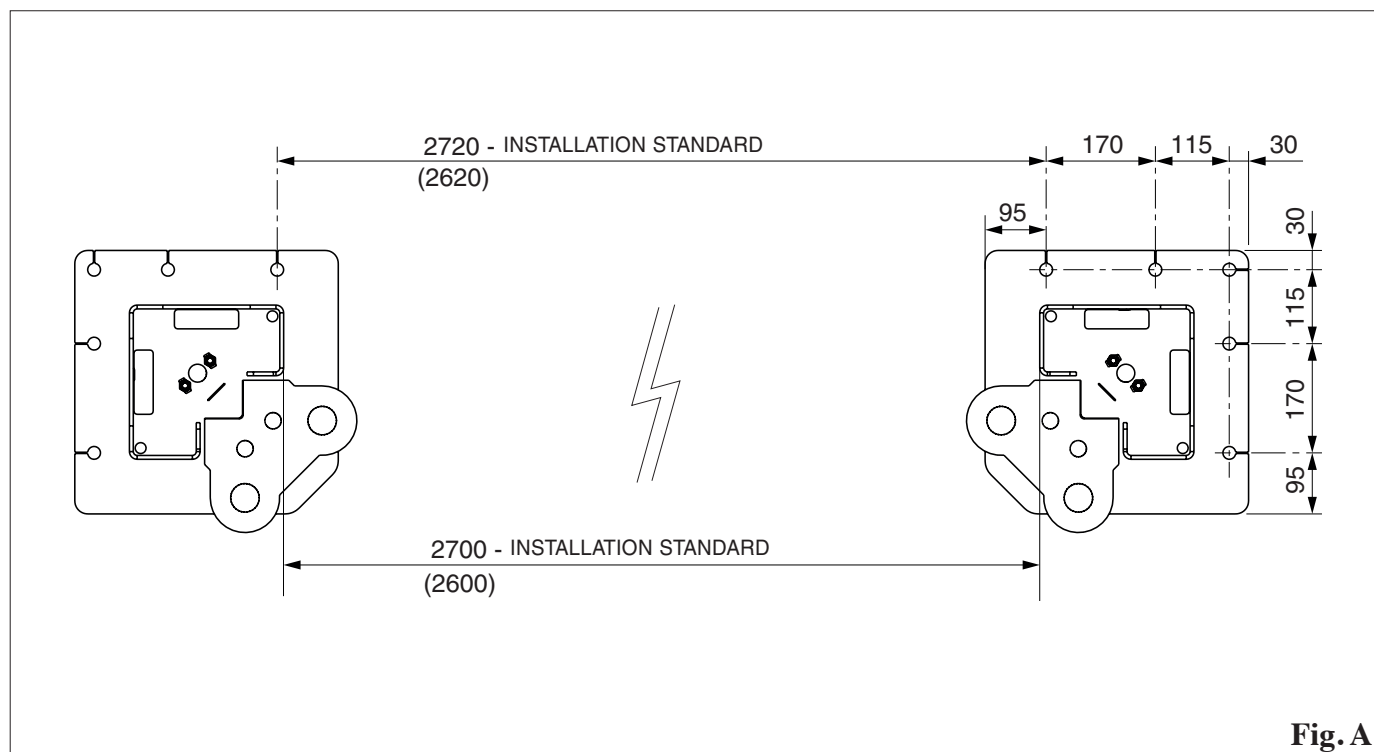
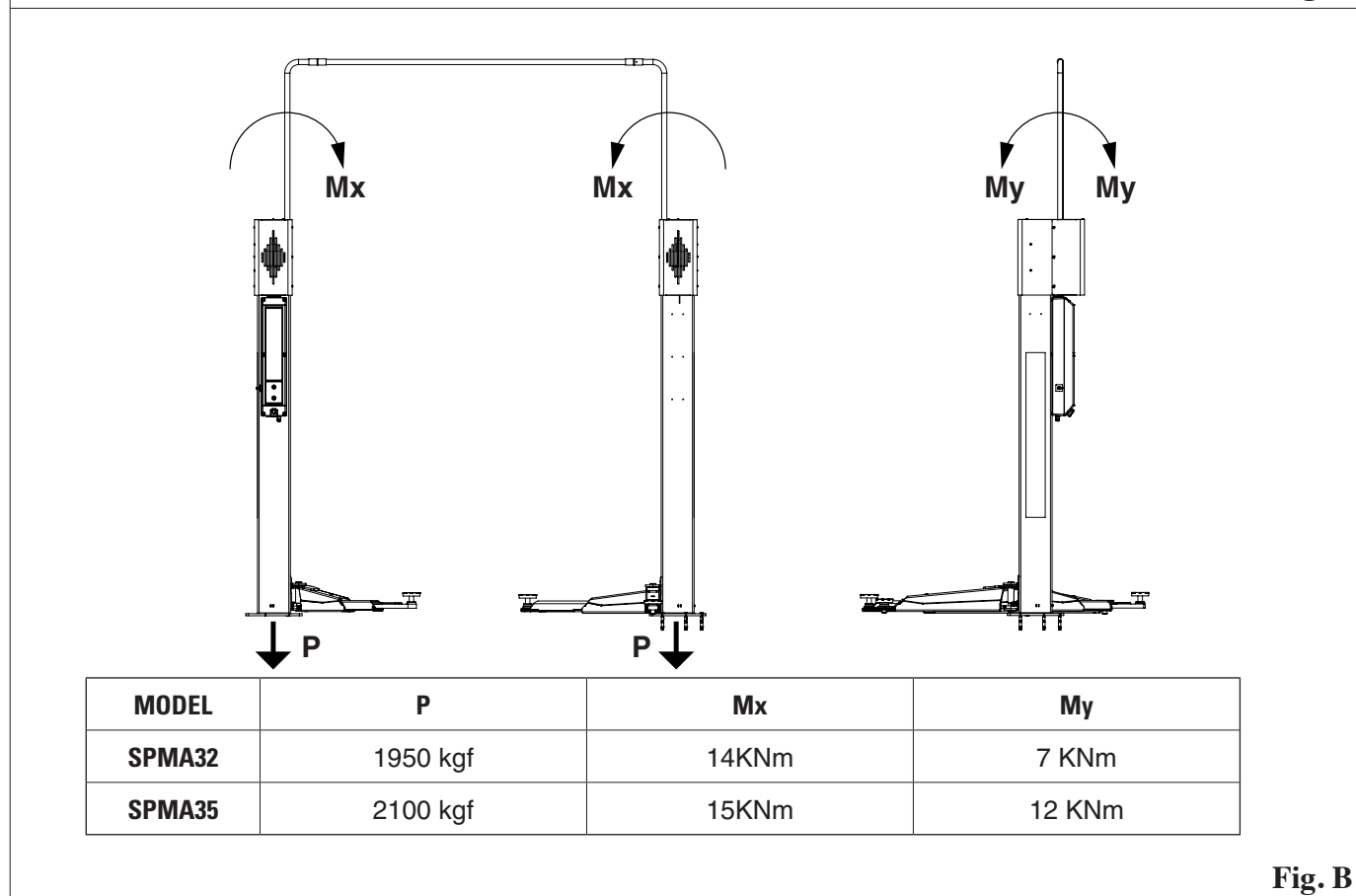
Fig. A

Fig. B

CHAP. 6 DÉPLACEMENT ET PRÉ-INSTALLATION

- Le pont élévateur est livré comme illustré à la figure **A**.
- L'emballage (A) contient les accessoires et les petites pièces pour compléter l'assemblage.
- Les opérations de levage doivent être réalisées comme indiqué à la figure **B**.
- Soulever avec attention et transporter les différents groupes à l'endroit choisi pour le déballage.

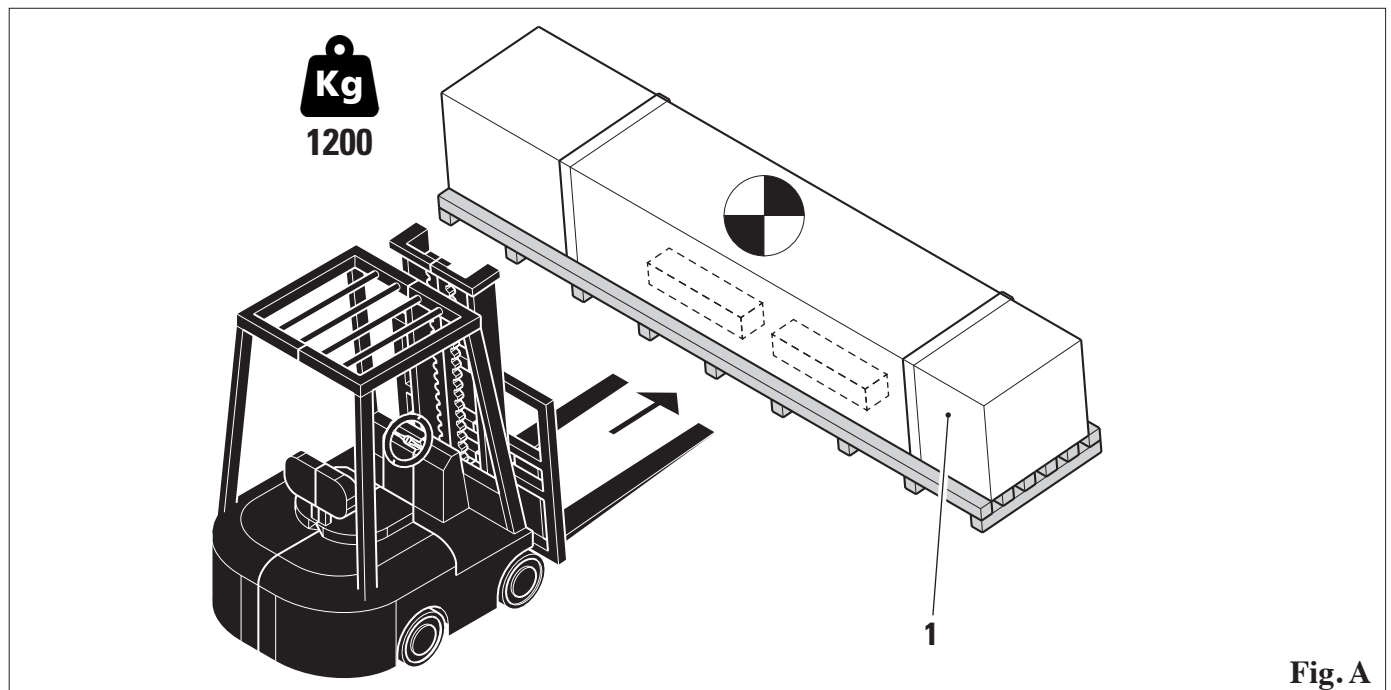
- Pour le déplacement de la machine à l'endroit choisi pour l'installation (ou dans le cas d'une réinstallation successive) s'assurer de:
 - soulever avec attention, en utilisant des moyens de soutien de la charge appropriés, parfaitement efficaces et en utilisant les points d'attelage comme indiqué à la figure **B**.
 - éviter les secousses et les à-coups imprévus, faire attention aux différences de niveau, aux défoncements, etc...;
 - prêter un maximum d'attention aux parties saillantes: obstacles, passages difficiles, etc...;
 - porter des vêtements appropriés et des protections individuelles;
 - après avoir retiré les différentes parties de l'emballage, les déposer dans des endroits de ramassage spéciaux, inaccessibles aux enfants et aux animaux, et les éliminer.
 - au moment de la livraison, vérifier l'intégrité de l'emballage et, au moment du déballage, vérifier que le matériel ne soit pas endommagé.

Fig. A

Procédure de manipulation :

Monter le piton (2) (*en option*) sur la vis (3).

Positionner la sangle (4) dans le piton et sur le support de charge, comme indiqué sur la fig.

Soulever délicatement la colonne jusqu'à ce qu'elle soit en position verticale.

Retirer la sangle du piton.

Déposer le piton (2).

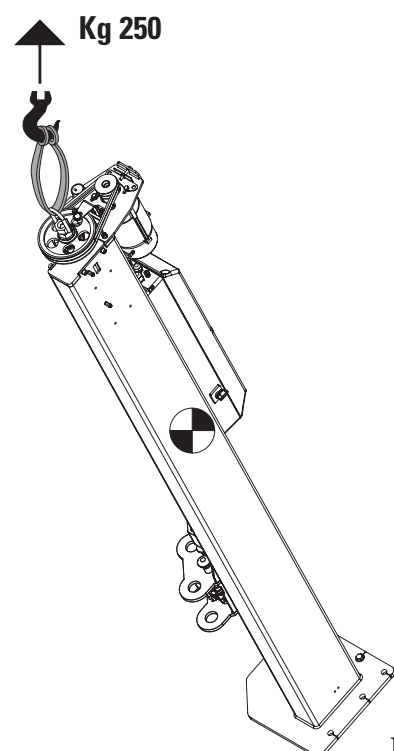
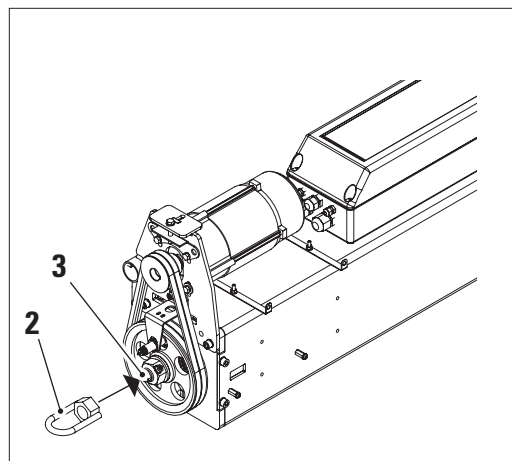
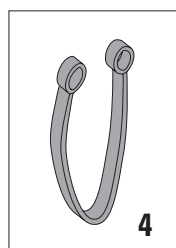
Fig. B

CHAP. 7 INSTALLATION

7.1 CHEVILLES

L'élévateur doit être fixé au plancher au moyen de chevilles mécaniques expansibles du type HILTI HSL-3 M12 ou similaire ou au moyen d'ancrages chimiques dans des flacons HILTI HVU-M12 ou similaires (avec barre filetée M12 en acier de classe 5.8 ou supérieure). En fonction de la profondeur du béton par rapport au niveau du sol, LES CHEVILLES DOIVENT ÊTRE D'UNE LONGUEUR APPROPRIÉE POUR ATTEINDRE LE SOL PORTEUR. (voir fig. A-B).

7.2 BÉTON

Pour les bétons de classe inférieure, il est recommandé d'utiliser des chevilles chimiques appropriées.

N.B. : il est recommandé de placer la base des colonnes directement sur le béton, même en présence d'un dallage. Toutefois, si celui-ci est de bonne qualité, il est possible de fixer les colonnes directement sur le sol, en utilisant des ancres de longueur appropriée.

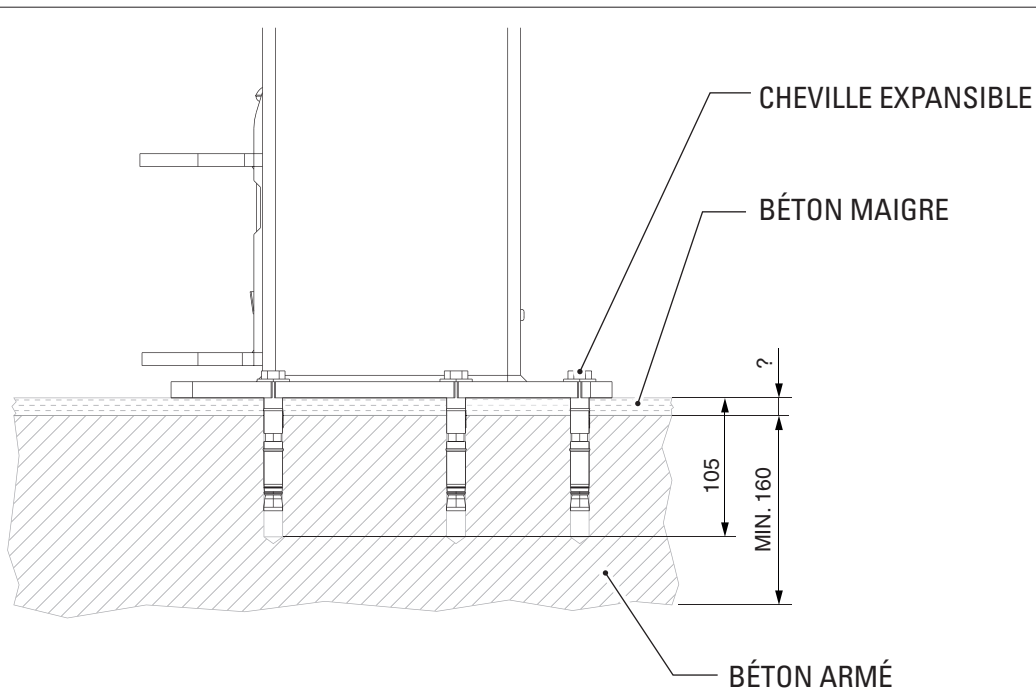
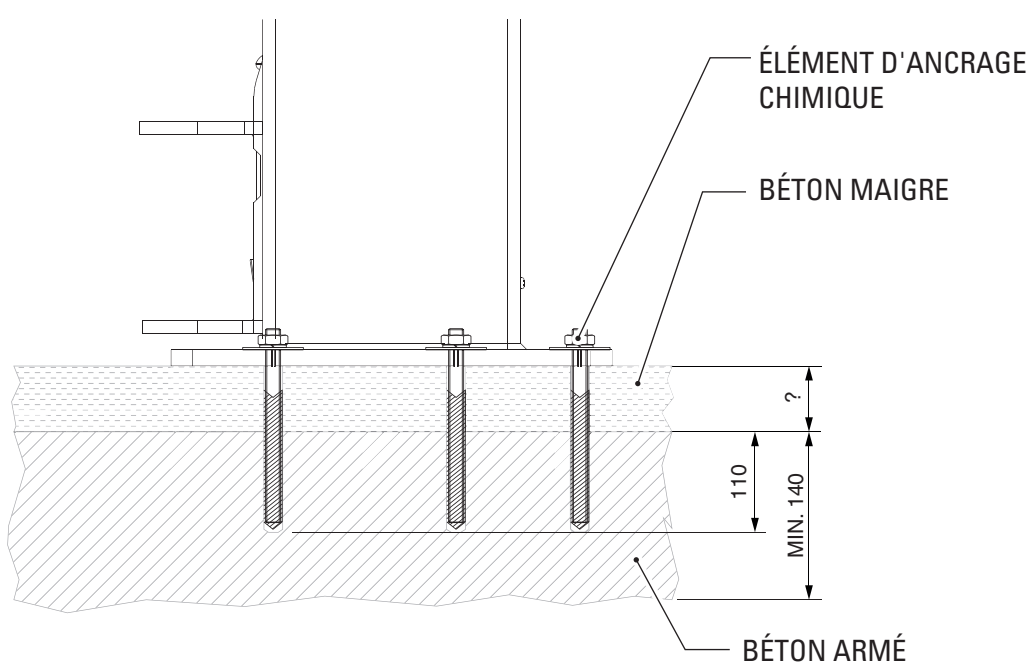
Fig. A

Fig. B

7.3 INSTRUCTIONS POUR L'INSTALLATION



La pose des vis tamponnées doit se faire en utilisant les bases comme gabarit de perçage.

NB : Se référer aux spécifications techniques fournies par le fabricant des chevilles pour les méthodes d'installation et d'application des chevilles.

Procédure d'installation :

- positionner une colonne à la verticale ;
- Caler toute lumière sous la plaque de base (fig.B)
- tracer les trous et les percer en suivant les procédures indiquées par le fabricant des chevilles ;
- fixer la cheville en position ;
- amener l'autre colonne à la verticale et la positionner à la distance indiquée dans le **chap. 5.2** ;
- procéder aux étapes de perçage et de fixation des chevilles décrites ci-dessus pour les deux colonnes.

⚠ ! Vérifier l'ancrage après avoir effectué une dizaine de courses à pleine charge, en contrôlant le couple de serrage des vis tamponnées. Ce contrôle doit être effectué tous les 3 mois.

- Monter le tube passe-câbles (1) sur les plaques de support du moteur.
- Faire passer le câble électrique (2) à l'intérieur du tube (1).
- Effectuer les connexions à la boîte de dérivation (fig. C).

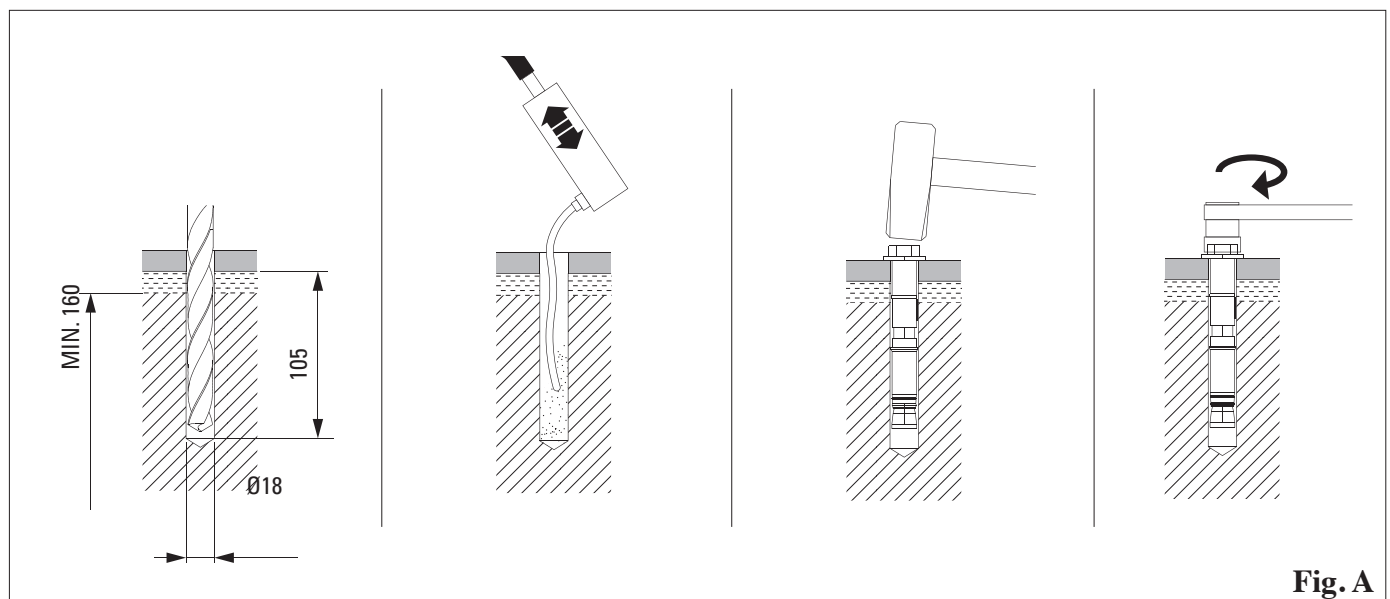

Fig. A

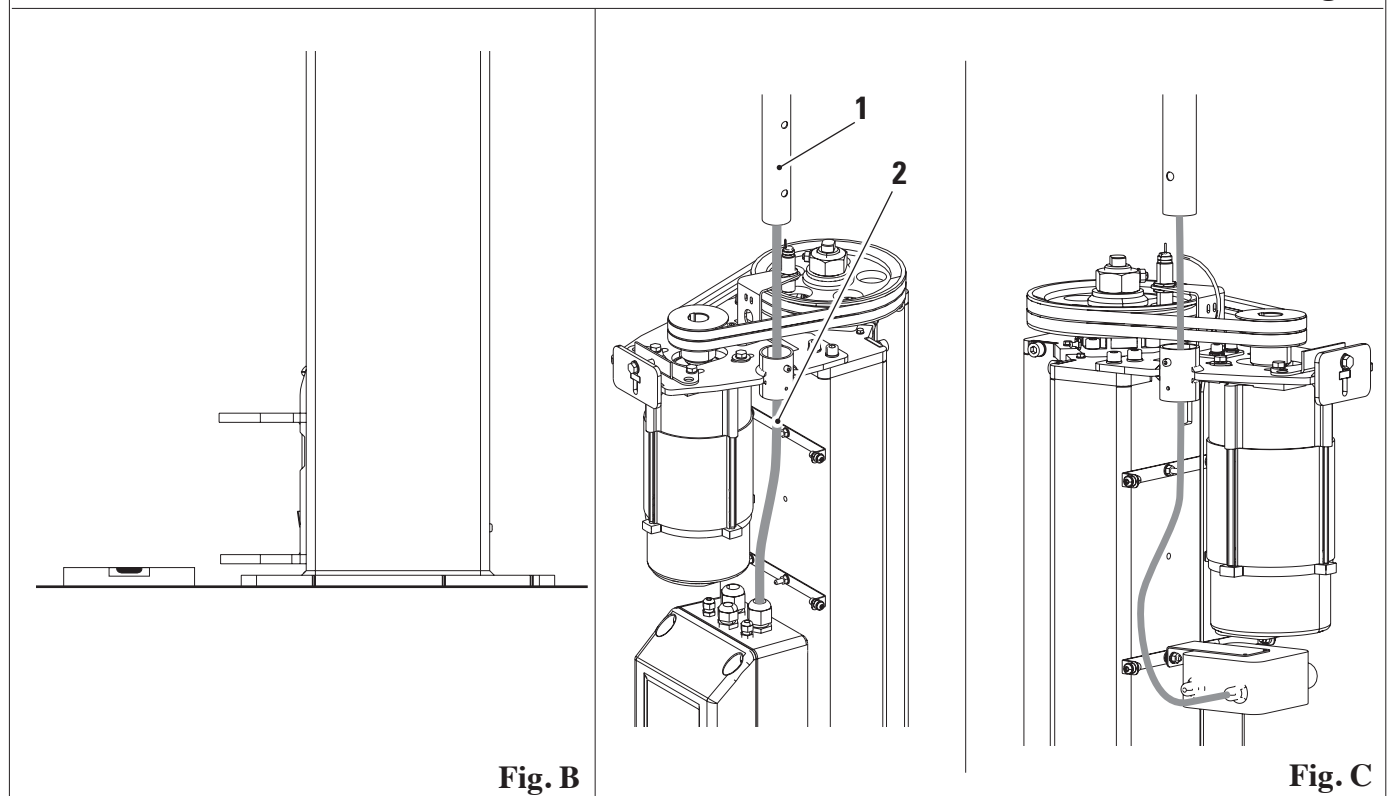

Fig. B

Fig. C

7.4 CONTRÔLE DE LA TENSION

Contrôler que la tension prévue pour l'installation électrique corresponde à celle du réseau.
 Dans le cas contraire, remplacer l'installation électrique et changer la tension du moteur.

7.5 CONNEXION AU RÉSEAU

Versión triphasée: 400V 50Hz 380V 60Hz

Section du câble >= 4mmq 3poli + terra P=11KW I=20A

Versión triphasée: 230V 50Hz 220V 60Hz

Section câble >= 6mmq 3poli + terra P=11KW I=32A

Contrôler entre autres la présence en amont d'un dispositif de coupure automatique contre les surintensités équipé de disjoncteur de 30mA..

7.6 CONNEXIONS

- Introduire le câble d'alimentation dans la boîte en le passant par le presse-câble et raccorder les fils à la barrette de connexion (voir schéma électrique).

Première mise en place.

Attention: l'élévateur pourrait se trouver les chemins pas en ligne à cause de l'emballage.

Porter les chariots au sol (fin de course descente) en suivant les indications du chap. 8.5 du manuel.

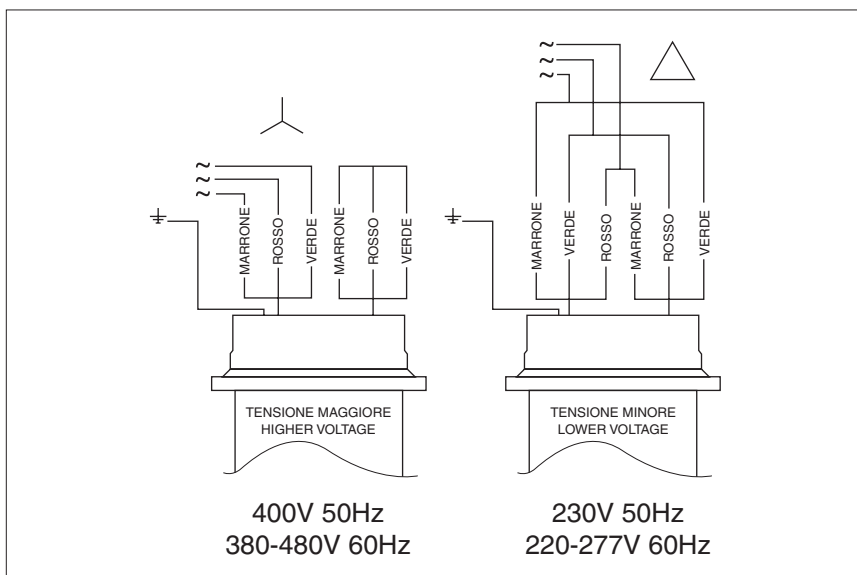
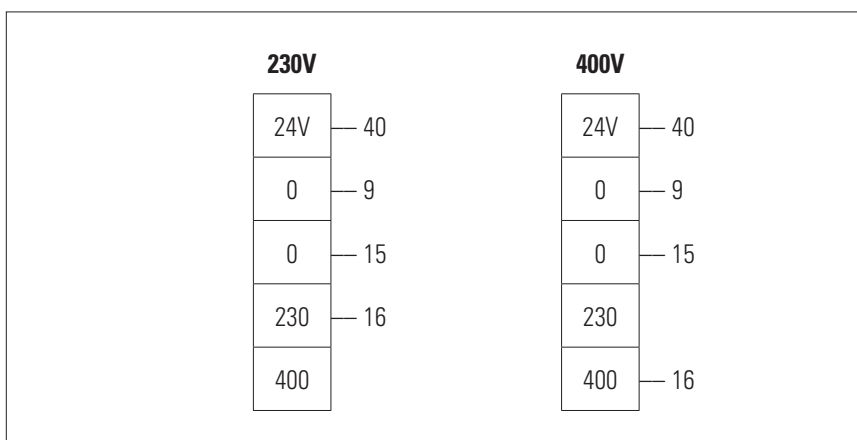

Les interventions sur la partie électrique, même si elles sont de petite importance, sont du ressort exclusif d'un personnel qualifié.

CONNEXION DU MOTEUR

CONNEXION DU TRANSFORMATEUR

FUSIBLES

L'installation électrique est adaptée pour fonctionner à la même tension que celle indiquée sur la plaque d'identification.

7.7 COMPLÈTEMENT DE L'INSTALLATION ET CONTRÔLE

- Actionner la commande de descente et agir manuellement sur la butée de fin de course inférieure: la manoeuvre de descente doit s'arrêter.
- Actionner la commande de montée pour porter les chariots à leur hauteur maximale et contrôler que l'arrêt est provoqué par l'intervention de la butée de fin de course supérieure.
- Remplir les bacs des colonnes avec de l'huile ESSO GEAR OIL GX 85W -140 jusqu'au niveau indiqué (voir chap. 10).
- Monter la plaque du capteur de poulie sur les deux colonnes Fig. **A**. Vérifier la présence d'un espace de 0,5 mm entre le capteur et la poulie (Fig. **B**).

- Monter les carters comme indiqué sur la fig. **C** :
 - monter le carter (1) en le fixant aux supports (2) ;
 - monter le carter (3) en le fixant au carter (1) et aux supports (4) ;
 - monter le carter (5) en le fixant aux carters (1) et (3).

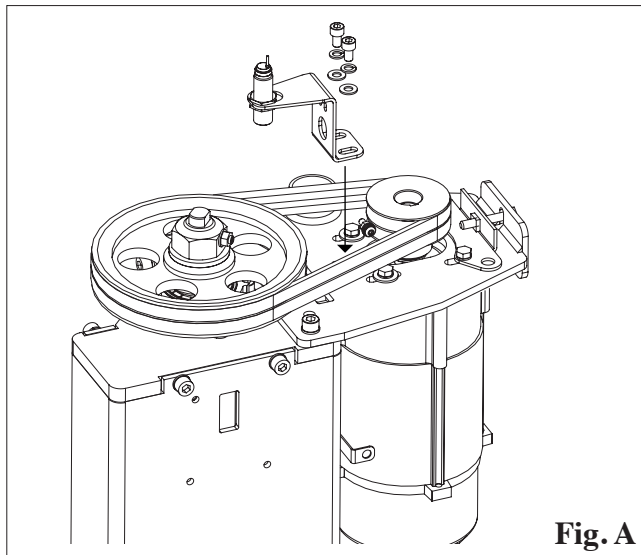
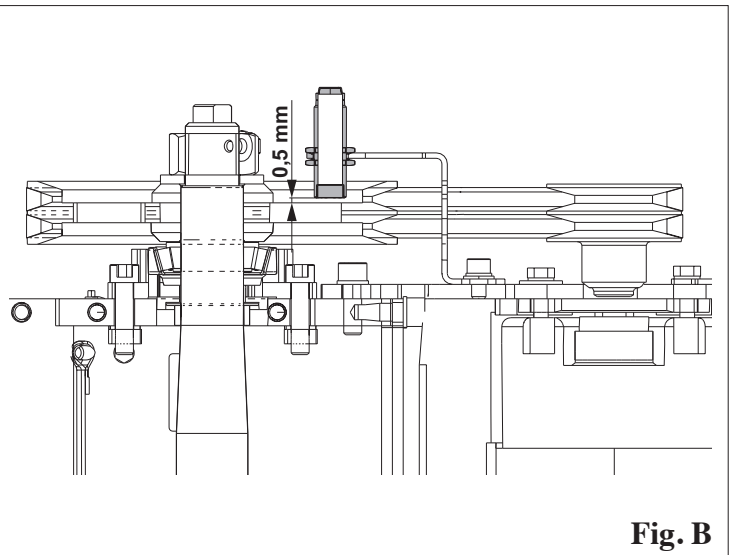
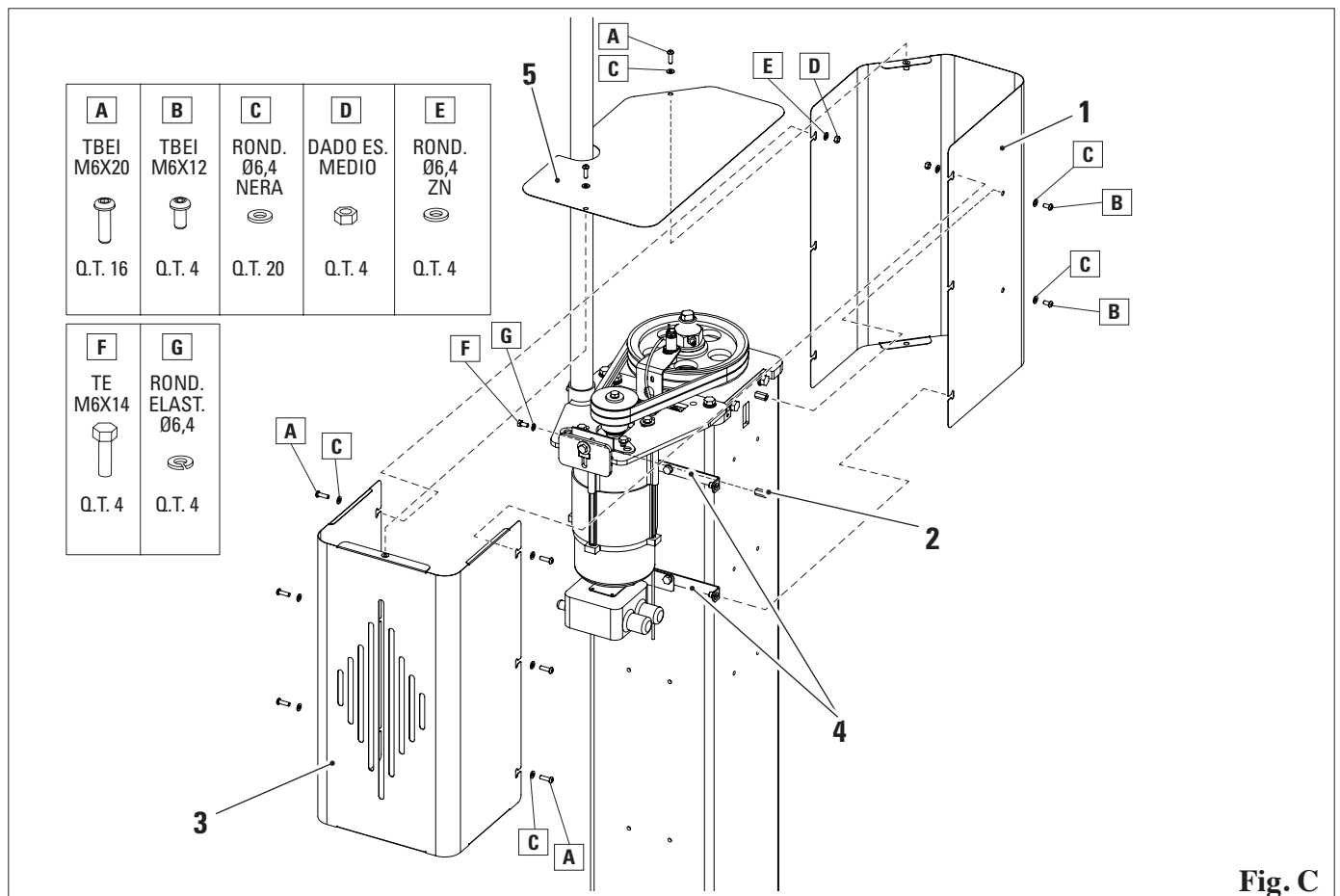

La plaque d'identification doit rester bien visible après l'installation.

Fig. A

Fig. B

Fig. C

7.8 MONTAGE BRAS



- Soulever les chariots à une hauteur de 70-80 cm.

- Monter les bras longs et courts :

déposer la roue dentée (1) en dévissant les vis respectives ; enlever la goupille (2) ; insérer le bras à l'intérieur des ailes du chariot et remonter la goupille (2) et la roue dentée (1) en la fixant avec les vis.

7.9 UTILISATION D'ACCESSOIRES

L'élévateur peut être utilisé avec des accessoires pour faciliter le travail de l'opérateur.

  *Seuls les accessoires d'origine du fabricant peuvent être utilisés.*

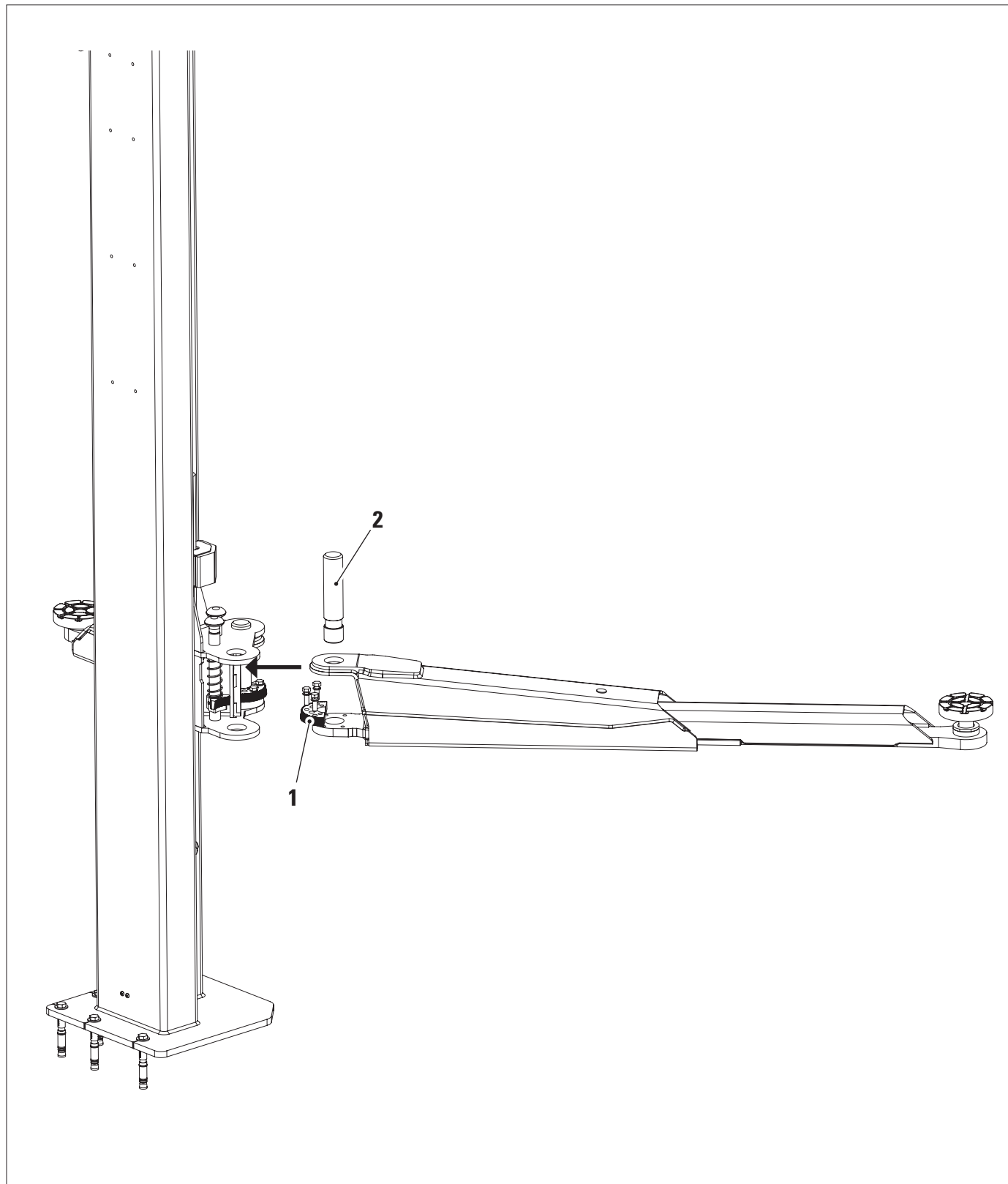

CHAP. 8 EMPLOI DU PONT ELEVATEUR



8.1 PRÉCAUTIONS POUR L'EMPLOI



Il est absolument interdit de se tenir sous le véhicule pendant les opérations de montée et de descente !

- Contrôler l'absence de toute condition dangereuse pendant les manoeuvres. Arrêter immédiatement la machine en cas d'irrégularités de fonctionnement et s'adresser au Service Après-Vente du revendeur autorisé.
- Contrôler que la zone de travail autour de la machine soit libre de tout objet potentiellement dangereux et qu'il n'y ait pas d'huile (ou autre produit glissant) sur le sol, car cela constitue un danger pour l'opérateur.
- L'opérateur doit porter un vêtement de travail approprié, des lunettes de protection, des gants et un masque pour éviter d'être blessé par les projections de poussières ou d'impuretés. Ne pas porter d'objets pendants comme les bracelets ou similaires. Les cheveux longs doivent être protégés par tout moyen opportun. Porter des chaussures indiquées pour le type d'opération à effectuer.
- S'assurer que le démontage de certaines parties du véhicule n'altère pas la répartition de la charge au-delà des limites acceptables prévues.
- Pour toute intervention sur le véhicule soulevé, positionner l'interrupteur général sur le zéro.

8.2 MANIPULATION ET COMPORTEMENT PENDANT LES FONCTIONS DE L'ÉLEVATEUR

Suivre les procédures décrites ci-dessous :

- Identifier le poids du véhicule.
 - Identifier la répartition de la charge.
 - Veiller à centrer le véhicule par rapport au pont aussi précisément que possible.
 - Identifier les points de prise du véhicule et suivre les instructions du fabricant.
- **Procédure pour le positionnement correct des tampons** : utiliser les mains comme prise pour déployer le bras télescopique (voir figure) ; diriger le tampon et le positionner sur les points de prise du véhicule identifiés précédemment. Ne pas utiliser les pieds ou tout système autre que ceux indiqués.
- Lever le chariot à une hauteur légèrement supérieure à 30 cm et, en exerçant une pression sur le véhicule, vérifier la bonne stabilité des points de prise et l'engagement des arrêts.
 - Pendant le mouvement de montée et de descente, vérifier le point d'appui sur le véhicule.

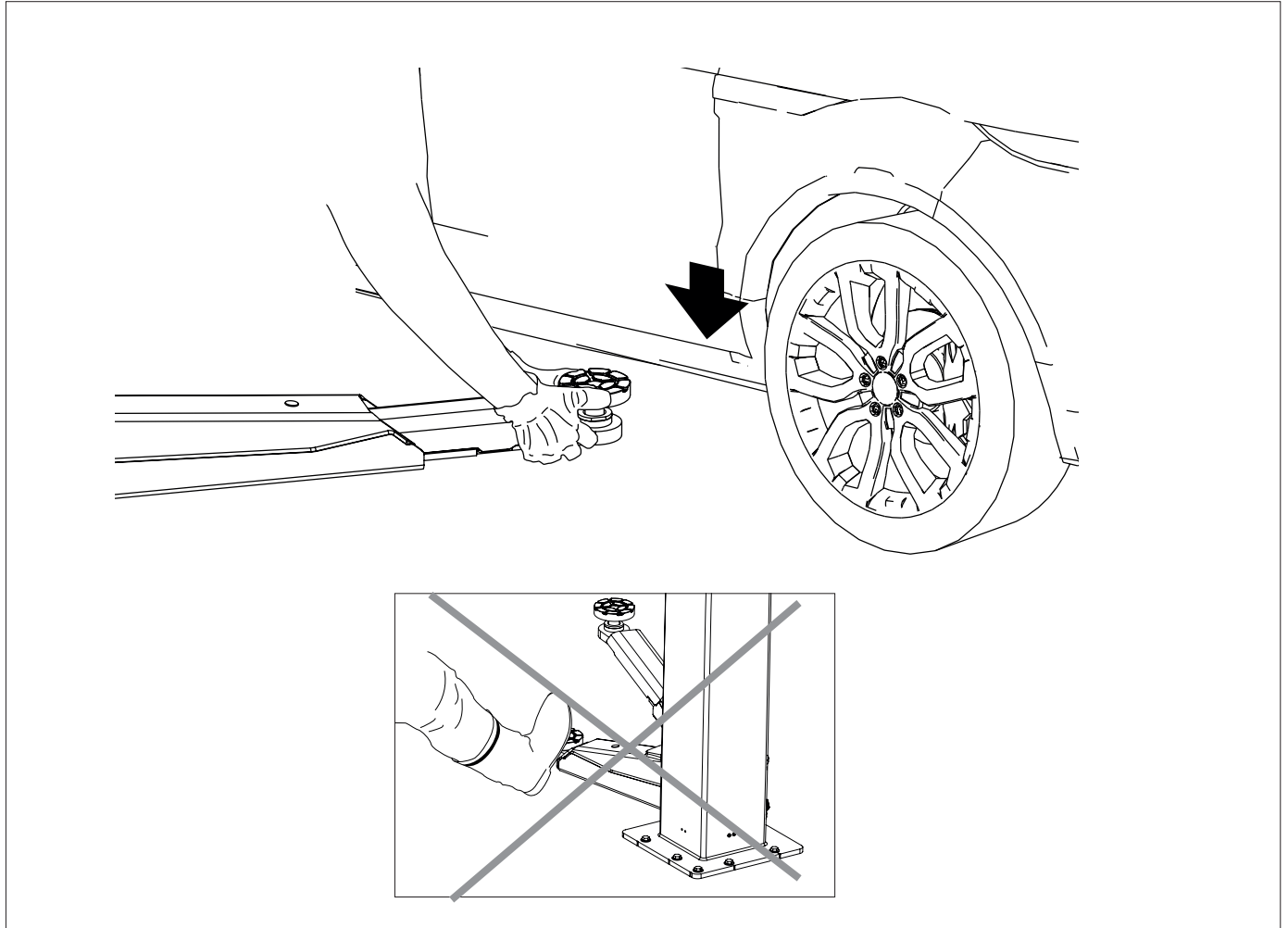

8.3 IDENTIFICATION ET FONCTION DES COMMANDES

 Boîtiers de commande code **047303060 - 047303070 / 047303080**

 Identification des commandes : **INTERRUPTEUR (1), BOUTON (2), BOUTON (3) AVERTISSEUR SONORE (4), BOUTON D'URGENCE (5)**

Fonction :

	<ul style="list-style-type: none"> • Circuit électrique désactivé • Position cadenassable
	<ul style="list-style-type: none"> • Circuit électrique activé • TEqLINK activé • Boutons (2) et (3) désactivés
	<ul style="list-style-type: none"> • TEqLINK activé • Position cadenassable

	Enfoncé : manipulation en montée
	Enfoncé : manipulation en descente
	Enfoncé : désactivation du circuit électrique
	Actif : élévateur en blocage et chariots à une hauteur dangereuse avec commande de descente actionnée

047303060

Boîtier de commande avec interrupteur et boutons montée/descente.

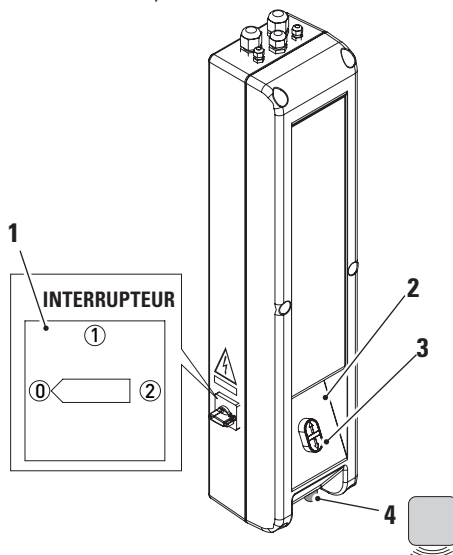
047303070 / 047303080

Double boîtier de commande avec interrupteur, boutons montée/descente, bouton d'urgence.

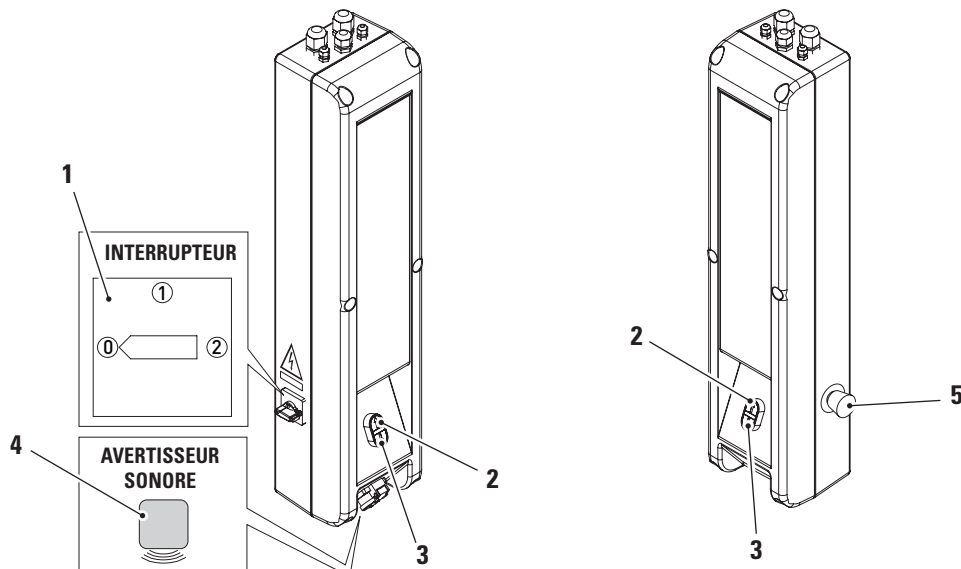

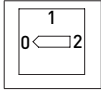
PROCEDURE DE SECOURS: DESCENTE EN CAS D'ABSENCE DE TENSION

Tourner l'interrupteur sur la position 0 (éliminer la possibilité d'un retour de l'alimentation).

- **DESCENTE D'URGENCE** : En cas de coupure de courant, il est possible de ramener la charge au sol en retirant les carters au sommet des colonnes et en faisant tourner les vis de manœuvre, en alternant la colonne de commande et la colonne opposée de façon à ne pas dépasser 50 mm de différence entre les cotes des chariots, avec une clé de 17 mm.

Une fois le circuit électrique rétabli, il faut réinitialiser les contacteurs en faisant monter le pont de 5 cm, puis en le faisant redescendre.



ATTENTION ! L'opération doit être effectuée par un personnel qualifié, qui prend garde à la position de la charge en évitant tout déséquilibre entre les deux chemins de roulement, car cela peut compromettre la stabilité de la charge.

8.4 UTILISATION INCORRECTE DU PONT ÉLÉVATEUR

L'élévateur est destiné à lever des véhicules ayant les caractéristiques spécifiées aux chap. 2. et 3.

Toute autre utilisation doit être considérée comme incorrecte et irraisonnée; il est tout particulièrement interdit:

- 1) de soulever des personnes ou des animaux;
- 2) de soulever des véhicules avec des personnes à bord;
- 3) de soulever des véhicules chargés de matériel potentiellement dangereux (explosifs, corrodants, inflammables, etc...);
- 4) de soulever des véhicules qui NE sont PAS positionnés sur les points d'appui.
- 5) de soulever des véhicules avec des accessoires qui ne sont pas prévus par la Société ROTARY
- 6) d'utiliser le pont élévateur sans formation adéquate et sans autorisation.
- 7) Utilisation comme cric.
- 8) Utilisation d'une seule paire de bras dans le sens longitudinal ou transversal.
- 9) Utilisation d'un seul bras.
- 10) Utilisation des bras pour compresser et écraser.

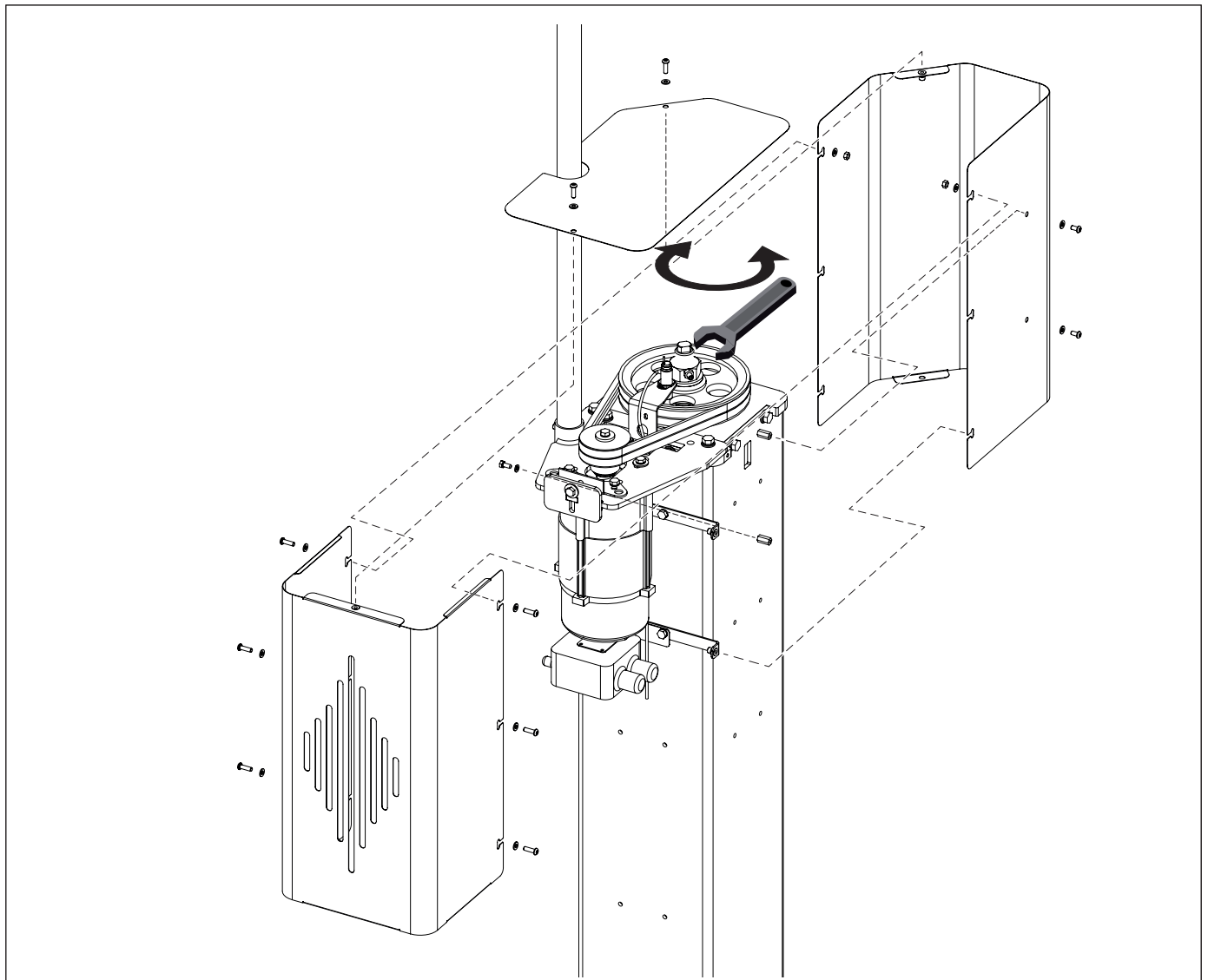

8.5 FONCTIONNALITÉ DISPOSITIF DE CONTRÔLE SYNCHRONISATION.

Attention !

Les vérifications et les procédures d'urgence nécessitent l'intervention d'un technicien spécialisé à cause de la présence de tension électrique.

Le tableau loge une carte électronique (1) disposant d'une DEL (2) qui reste allumée lorsque l'interrupteur est dans les conditions suivantes :

 Interrupteur boîtier de commande code **047303060 - 047303070**

	<ul style="list-style-type: none"> • Circuit électrique activé • TEqLINK activé
	<ul style="list-style-type: none"> • Boutons (4) et (5) désactivés • TEqLINK activé • Position cadenassable

Inconvénient : blocage du pont (signalisation avertisseur sonore).

Solution : la descente d'urgence est possible (descente individuelle).

- Si le pont est en état de blocage il est possible de faire descendre les chariots.

- Tourner sur .

- Retirer le couvercle de la boîte électrique.

- Déplacer vers le bas le levier (3) en mode manuel (A).

- Tourner sur .

Descente individuelle des chariots. Actionner la commande de descente et simultanément appuyer sur :

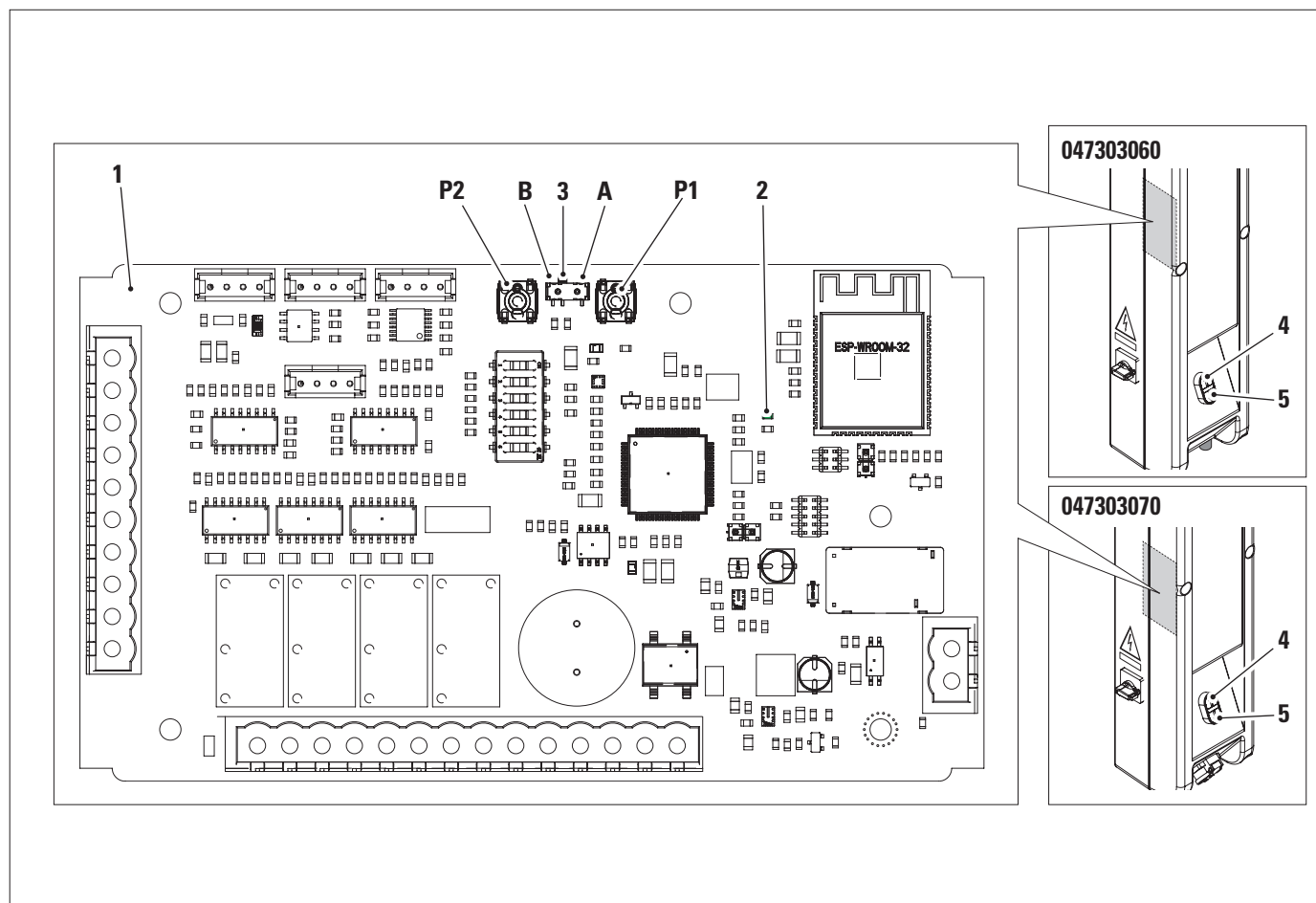
 - le bouton **P1** pour déplacer le chariot de la colonne de commande ; le bouton **P2** pour déplacer le chariot de la colonne opposée.



Attention : pendant la descente en mode manuel le système de synchronisation des chariots n'est pas actif. Effectuer ces opérations correctement et avec beaucoup de soin, afin d'éviter tout désalignement dangereux du véhicule.

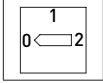

- Faire descendre les deux chariots, le dernier atteignant le fin de course descente réinitialise le blocage (avertisseur sonore éteint avec la commande de descente actionnée).

- Tourner sur .

- Sur la carte, mettre le levier (3) sur (B) (en mode automatique).
- Poser le couvercle de la boîte électrique.

N.B. : en mode manuel exclusivement la descente est admise.

Si la manœuvre ne peut pas être réalisée, cela signifie que la carte est bloquée en état de sécurité due à la détection d'une condition dangereuse.

Pour rétablir le blocage de sécurité agir de la manière suivante :

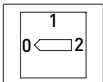
- Tourner sur .

- sur la carte, mettre le levier (3) sur (A) (en mode manuel) ;

- appuyer simultanément sur les boutons **P1** et **P2** et tourner .

- maintenir les boutons **P1** et **P2** enfoncés pendant 5 secondes ;
- la DEL (1), déjà allumée, clignotera une fois ;
- mettre le levier (3) sur (B) (en mode automatique).

Attention :

- si le blocage a été causé par une panne matérielle (carte ou installation électrique), le blocage surviendra tout de suite ;
- si la panne concerne la carte il faudra la remplacer ;
- si la panne concerne l'installation il faudra la résoudre.

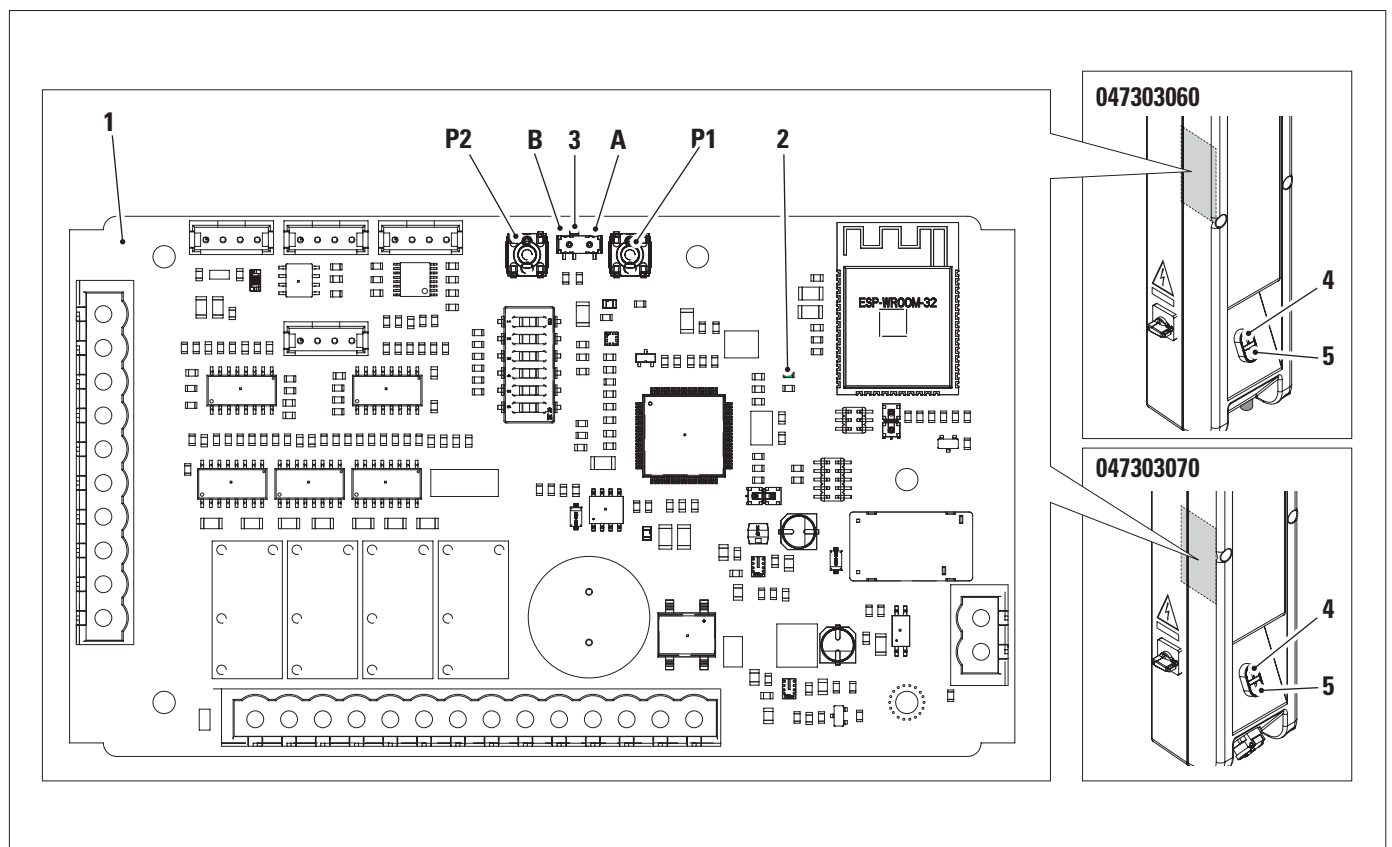

CHAP. 9 DISPOSITIFS DE SECURITE

Interrupteur principal verrouillable

Interrupteur boîtier de commande code 047303060 - 047303070	
	<ul style="list-style-type: none"> • Circuit électrique désactivé • Position cadenassable
	<ul style="list-style-type: none"> • Boutons désactivés • TEqLINK activé • Position cadenassable

Système (de sécurité "d'homme-mort")

Le pont élévateur est équipé d'un système (dit "d'homme mort"): les opérations de montée ou de descente commandées sont immédiatement interrompues lors du relâchement du poussoir.

Arrêts mécaniques

Le pont est doté d'arrêts mécaniques intervenant en cas d'anomalies du fin de course, au bout de la course de montée ou de descente. Dans de telles situations, contrôler la manœuvre opposée à l'opération précédente pour une course de 5 à 10 cm par à-coups. Contrôler le fin de course concerné et le remplacer, le cas échéant.

En plus des arrêts mécaniques susmentionnés, il se peut que la sonde thermique du moteur se désenclenche ; le réarmement automatique de cette dernière aura lieu après environ 3 minutes.

Synchronisme de levage



La responsabilité du fabricant ne peut être mise en cause pour les dommages dérivant de toute altération ou modification de l'équipement non autorisée préalablement par le fabricant.

La suppression ou l'altération des dispositifs de sécurité comporte une violation des Normes Européennes en matière de sécurité.

Lorsque la différence de niveau entre les deux chariots atteint 18 mm, le contrôleur rétablit l'alignement correct automatiquement.

Arrêt d'urgence

Ce type d'arrêt intervient lorsque:

- le désalignement des chariots est supérieur à 40 mm;
- les moteurs s'arrêtent;
- le câble d'alignement se casse.

Quoi faire en cas d'arrêt de secours

- Lorsque le pont-élévateur est dans l'arrêt de secours (voir par. précédent), on ne peut pas commander par les boutons-poussoirs ni la montée ni la descente. Pour rétablir le fonctionnement, il faut s'adresser au Service Après-Vente.
- Pour descendre le véhicule du pont, baisser les chariots en actionnant les poulies manuellement.

Arrêt usure écrou

Si le pont élévateur continue à travailler au delà de la limite indiquée au CHAP. 10.2, on provoquera l'actionnement de l'arrêt de sécurité usure écrou.

Le déclenchement du dispositif se fait lorsque les chariots atteignent les fins de course de descente.

Il est signalé par l'avertisseur sonore, qui est actif en mode : **1sec. ON** et **1sec. OFF**.

CHAP. 10 ENTRETIEN

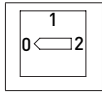

Positionner l'interrupteur principal sur le "0" (zéro) si des opérations d'entretien doivent être effectuées.



Attention: organes mécaniques en mouvement. Toute levée des carters de protection est aux risques et périls de la personne l'ayant effectuée.



10.1 ACTIVITÉS DE MAINTENANCE

Effectuer des contrôles périodiques des dispositifs de sécurité tous les 3 mois.



Une évaluation de la durée de vie résiduelle est requise après 10 ans d'utilisation de l'élévateur, effectuée par un technicien qualifié, de préférence autorisé par le fabricant.

• SUR UNE BASE MENSUELLE

Écrous porteurs - Déposer les rideaux de protection avec les chariots à 50 cm du sol, contrôler les écrous à l'aide de la plaque (1) fournie : elle doit être insérée dans la rainure comme indiqué sur la figure ; si le côté STOP ne peut pas être positionné, remplacer l'écrou.

• SUR UNE BASE TRIMESTRIELLE

Rails de guidage - Lubrifier les rails de guidage des patins en les recouvrant de graisse (fig. B).

Roulements - Retirer les carters de protection du moteur et injecter de la graisse dans les graisseurs (2).

• SUR UNE BASE ANNUELLE

Bacs de lubrification - Déposer les rideaux de protection et procéder à l'appoint du bac (3) de lubrification avec de l'huile (ESSO GEAR OIL 85W-140 ou équivalent).

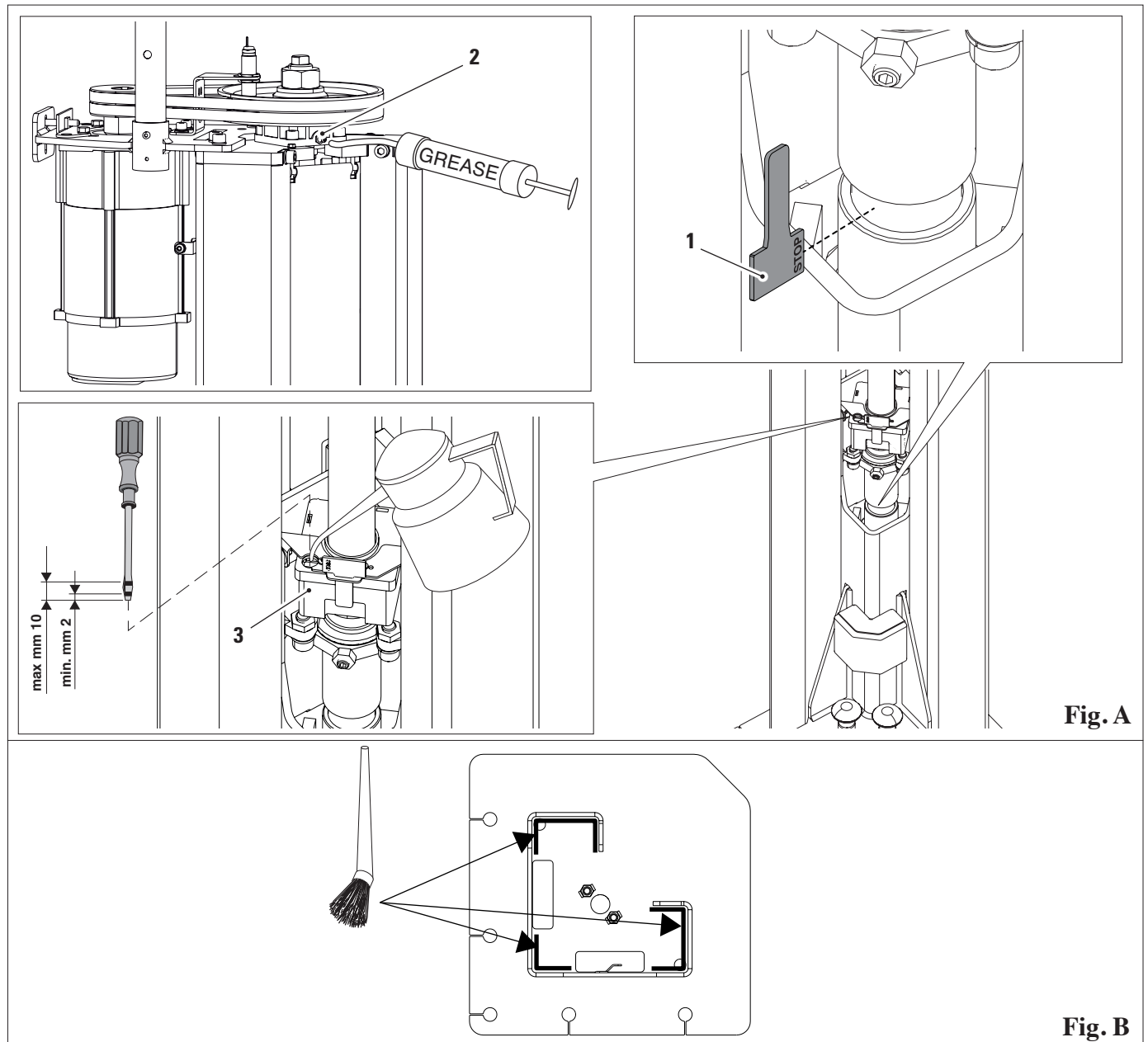

Programme d'entretien programmé

Intervalle de TEMPS	Type d' ENTRETIEN	Plan d' ENTRETIEN	POSITION*	CRITICITÉ
JOUR	AUTOCOLLANTS	Vérifier et, si nécessaire, remplacer les autocollants de sécurité endommagés ou illisibles	Sur la colonne Sur le tableau	MOYENNE
	BRAS	Vérifier l'état du protège-pieds, l'usure ou les dommages ; si nécessaire, remplacer	Bras	MOYENNE
	BRAS	Vérifier l'état des tampons, l'usure ou les dommages ; si nécessaire, remplacer	Bras	BASSE
MOIS	ROULEMENT	Graisser le roulement porteur de la vis (voir libellé actuel)	En tête de la vis	HAUTE
	ÉCROU	Vérifier l'état de la vis, l'usure ou les dommages ; si nécessaire, remplacer (voir libellé actuel)	En tête du chariot	HAUTE
	ÉCROU	Vérifier le niveau d'huile dans le bac de lubrification ; si nécessaire, procéder à l'appoint avec de l'huile (voir libellé actuel)	En tête du chariot	HAUTE
	ÉCROU DE SÉCURITÉ	Graisser le contre-écrou de sécurité avec une graisse multi-usages ; NE PAS utiliser de graisse à base solide (Molicote), comme le graphite.	En tête du chariot	MOYENNE
TRIMESTRE	RAILS DE GUIDAGE	Lubrifier les rails de guidage des patins des chariots avec de la graisse (sans suspension solide).		HAUTE
	CHEVILLES	Vérifier l'ancrage après une dizaine de courses à pleine charge en contrôlant le couple de serrage des chevilles.	Sur la colonne	HAUTE
ANNÉE	COURROIE	Vérifier la tension correcte de la courroie et son usure ; si nécessaire, tendre ou remplacer.	En tête de la colonne	HAUTE
	VIS	Vérifier l'état de la vis, l'usure ou les dommages ; si nécessaire, remplacer	À l'intérieur de la colonne	HAUTE
	COMPOSANTS ÉLECTRONIQUES	Vérifier l'état des composants électriques et électroniques : connexions intactes et dommages sur les borniers ou les connecteurs.	Tableau électrique	HAUTE
	PEINTURE	Vérifier l'absence de dommages et d'abrasions sur les surfaces peintes ; si nécessaire, poncer et peindre pour éviter les dommages causés par la rouille.	Colonne du chariot	MOYENNE
	SOUDURES	Vérifier l'absence de dommages et de fissures sur les soudures de la colonne, du chariot et des bras. Si nécessaire, nettoyer la zone et restaurer la soudure.	Colonne du chariot	HAUTE
	VIS DE FIXATION	Vérifier le serrage de toutes les vis de fixation. Si nécessaire, serrer avec une clé dynamométrique.		
	BRAS	1. Nettoyer et lubrifier les goupilles. 2. vérifier les ressorts des goupilles et, si nécessaire, remplacer et réparer 3. vérifier les dommages sur les bras et les arrêts des rallonges 4. vérifier le système d'arrêt des bras, les filets et l'usure ; si nécessaire, remplacer	Bras	MOYENNE
	PATINS	Vérifier l'absence de dommages et d'usure sur les patins et les rails de guidage. Si nécessaire, remplacer et caler les patins, en nettoyant la zone et en lubrifiant.	Chariot	MOYENNE

10.2 USURE DE L'ÉCROU ET REMPLACEMENT DU GROUPE DE VIS



L'usure de l'écrou porteur conduit à sa rupture, auquel cas le chariot s'abaisse de 20 mm.

Cette condition est détectée par la carte électronique lorsque les fins de course de descente sont activés, ce qui est signalé par l'avertisseur sonore qui fonctionne en mode 1sec. ON - 1sec. OFF.

Par conséquent, la manœuvre de montée ne peut pas avoir lieu.

La rupture de l'écrou nécessite le remplacement de l'ensemble du groupe de vis.

Procédure de remplacement du groupe de vis :

- Amener le chariot à une hauteur d'environ 350 mm et insérer un bloc de bois (1) sous le chariot.
- Couper l'alimentation de la machine.
- Déposer le rideau (2).
- Déposer les carters (3).
- Déposer le support de proximité (4) (attention : pas le dispositif de proximité de son support).
- Déposer les courroies d'entraînement (5).
- Tourner la poulie jusqu'à ce que le chariot soit en contact avec le bloc de bois (fig. C).
- Déposer l'élément anti-rotation du bac (6).
- Déposer la vis sans tête et l'écrou (7).
- Déposer les vis de retenue (8).
- Déposer les vis du support de roulement (9).
- Tourner l'écrou jusqu'à ce que l'écrou de sécurité atteigne sa butée (dans le sens des aiguilles d'une montre) (10).
- Visser le piton dans l'extrémité de la vis (11).
- Retirer le groupe de vis de l'intérieur du pont en effectuant un mouvement diagonal (fig. D).
- Réaliser les opérations dans l'ordre inverse pour le montage de la pièce de rechange (en faisant bien attention à fixer la vis sans tête).

- Procéder à la RÉINITIALISATION, voir chapitre 8.5

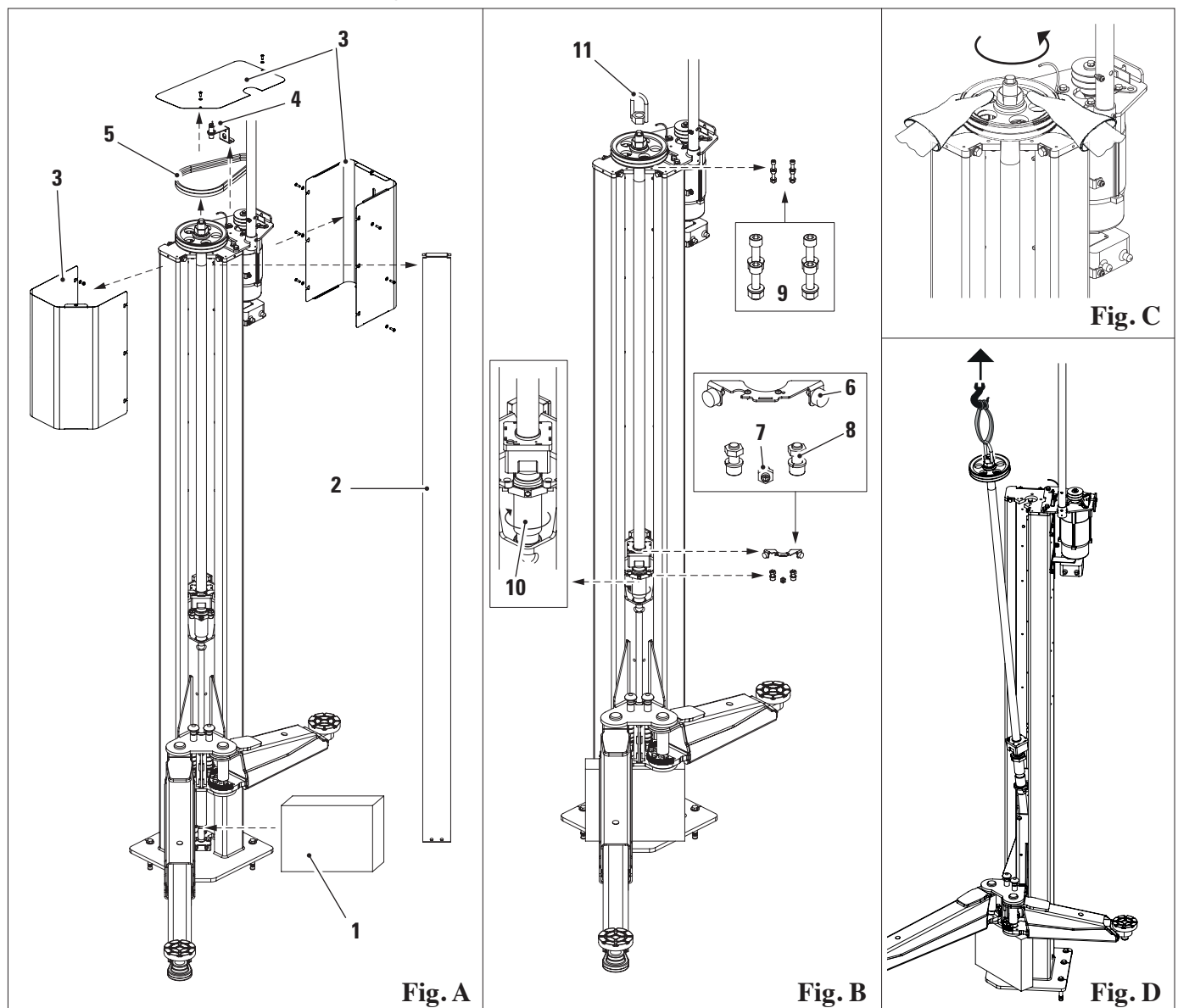

10.3 TROUBLE SHOOTING

Nous fournissons ici la liste des pannes éventuelles susceptibles de se manifester pendant le fonctionnement du pont. La Société ROTARY décline toute responsabilité en cas de dommages provoqués à des personnes, des animaux ou des choses et dus à une intervention de la part de personnes non autorisées. C'est pourquoi, en cas de panne, il est vivement recommandé de s'adresser le plus rapidement possible au Service d'Assistance Technique qui fournira toutes les informations pour réaliser les opérations et/ou les réglages en toute sécurité, et éviter de provoquer des dommages aux personnes, aux animaux et aux choses.



L'intervention de l'Assistance Technique est nécessaire. Toute autre intervention est interdite.

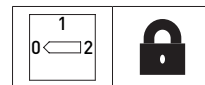

PANNE EVENTUELLES	CAUSES	REMEDES
Aucun fonctionnement. Avertisseur sonore éteint.	Tension d'alimentation.	Vérifier la tension dans les câbles d'alimentation. Vérifier l'interrupteur / l'inverseur de l'élévateur. Vérifier les fusibles de ligne. Vérifier le transformateur de commandes et ses fusibles.
Ne termine pas sa course. Avertisseur sonore éteint.	Désenclenchement de la sonde thermique du moteur.	Attendre le réarmement.
Aucun fonctionnement. Avertisseur sonore allumé.	Élévateur en blocage d'urgence.	Voir chapitre 8.5
	Interrupteur de proximité.	Régler / remplacer.
	Moteur arrêté.	Vérifier les courroies du moteur.
Aucun fonctionnement. Avertisseur sonore allumé : 2sec. ON / 2sec. OFF	Interrupteur de la carte en mode manuel après la réinitialisation du blocage.	Mettre l'interrupteur en mode automatique.
Ne soulève pas les chariots en fin de course de descente. Avertisseur sonore allumé : 1sec. ON / 1sec. OFF	Blocage pour cause d'usure des écrous.	Voir chapitre 10.2.
Aucun fonctionnement, pas même en mode manuel. Avertisseur sonore allumé.	Blocage de sécurité.	Voir chapitre 8.5

CHAP. 11 ÉLIMINATION-MISE AU REBUT

11.1 DÉMONTAGE

Les travaux de démontage ne doivent être effectués que par un personnel spécialisé autorisé. Seuls des électriciens qualifiés peuvent travailler sur l'installation électrique.

1. Pour effectuer les travaux de démontage, éteindre l'appareil au moyen de l'interrupteur principal (position OFF).
2. Débrancher l'alimentation électrique.
3. Vider le réservoir d'huile. Éliminer l'huile hydraulique et les fluides de fonctionnement comme indiqué au chapitre 11.3.
4. Enlever la graisse et les autres substances chimiques. Éliminer comme indiqué au chapitre 11.3.
5. Les opérations de démontage doivent être effectuées dans l'ordre inverse des étapes de montage (voir chap. 7).

11.2 STOCKAGE

- En cas de stockage prolongé, il faut débrancher les sources d'alimentation, vider le ou les réservoirs qui contiennent les liquides pour le fonctionnement et protéger les parties qui risquent d'être endommagées par les dépôts de poussière.
- Graisser les parties qui risquent de s'endommager si elles sèchent.
- Lors de la remise en service, remplacer les joints mentionnés au point Pièces de rechange.

11.3 ÉLIMINATION

Procédures environnementales pour l'élimination

Prévenir les risques environnementaux.

Éviter le contact ou l'inhalation de substances toxiques telles que le fluide hydraulique.

Les huiles et les lubrifiants sont des polluants de l'eau au sens de la loi sur la gestion de l'eau WGH. Toujours les éliminer dans le respect de l'environnement et conformément à la réglementation en vigueur dans son pays.

L'huile hydraulique à base d'huile minérale est un polluant de l'eau et est combustible. Se référer à la fiche de données de sécurité pour l'élimination.

S'assurer qu'aucune huile hydraulique, aucun lubrifiant ou produit de nettoyage ne contamine le sol ou n'est rejeté dans les égouts.

Emballage

Ne pas jeter avec les déchets ménagers ! L'emballage contient certains matériaux recyclables, qui ne doivent pas être jetés avec les déchets ménagers.

1. Éliminer les matériaux d'emballage conformément aux réglementations locales.

Huile, graisse et autres substances chimiques.

1. En travaillant avec des huiles, des graisses et d'autres substances chimiques, respecter les réglementations environnementales qui s'appliquent au produit en question.
2. Éliminer l'huile, la graisse et les autres substances chimiques conformément aux réglementations environnementales en vigueur dans son pays.

Métaux / Déchets électroniques

Ils doivent toujours être éliminés de manière appropriée par une entreprise certifiée.

RAPPORT D'INSTALLATION

OPÉRATION DE CONTRÔLE
A REMPLIR PAR L'INSTALLATEUR

Pont élévateur modèle _____ Numéro de série _____

Vérification de l'aptitude du sol	<input type="checkbox"/>
Contrôle de la tension d'alimentation	<input type="checkbox"/>
Interrupteur principal	<input type="checkbox"/>
Commande de la course de montée et de descente	<input type="checkbox"/>
Mouvement correct du chariot - commande d'actionnement	<input type="checkbox"/>
Contrôle du fonctionnement de la butée de fin de course de descente	<input type="checkbox"/>
Contrôle du couple de serrage des chevilles	<input type="checkbox"/>
Contrôle du glissement correct des bras télescopiques	<input type="checkbox"/>
Contrôle de l'engagement et déengagement corrects des arrêts mécaniques	<input type="checkbox"/>
Contrôle du niveau du dispositif de lubrification de la vis	<input type="checkbox"/>
Contrôle de la lubrification des glissières	<input type="checkbox"/>
Contrôle de la présence et de l'emplacement des étiquettes adhésives	<input type="checkbox"/>
Capacité	<input type="checkbox"/>
Recommandations	<input type="checkbox"/>
Numéro de série	<input type="checkbox"/>

Cachet et signature de l'installateur

Date d'installation

CONTROLE PERIODIQUE

Opération de contrôle	date		signature		date		signature		date		signature	
Contrôle de l'état d'usure de l'écrou	<input type="checkbox"/>		<input type="checkbox"/>		<input type="checkbox"/>		<input type="checkbox"/>		<input type="checkbox"/>		<input type="checkbox"/>	
Interrupteur principal	<input type="checkbox"/>		<input type="checkbox"/>		<input type="checkbox"/>		<input type="checkbox"/>		<input type="checkbox"/>		<input type="checkbox"/>	
Commande de la course de montée et de descente	<input type="checkbox"/>		<input type="checkbox"/>		<input type="checkbox"/>		<input type="checkbox"/>		<input type="checkbox"/>		<input type="checkbox"/>	
Contrôle du fonctionnement de la butée de fin de course de descente	<input type="checkbox"/>		<input type="checkbox"/>		<input type="checkbox"/>		<input type="checkbox"/>		<input type="checkbox"/>		<input type="checkbox"/>	
Contrôle du couple de serrage des chevilles	<input type="checkbox"/>		<input type="checkbox"/>		<input type="checkbox"/>		<input type="checkbox"/>		<input type="checkbox"/>		<input type="checkbox"/>	
Contrôle du glissement correct des bras télescopiques	<input type="checkbox"/>		<input type="checkbox"/>		<input type="checkbox"/>		<input type="checkbox"/>		<input type="checkbox"/>		<input type="checkbox"/>	
Contrôle de l'engagement et déengagement corrects des arrêts mécaniques	<input type="checkbox"/>		<input type="checkbox"/>		<input type="checkbox"/>		<input type="checkbox"/>		<input type="checkbox"/>		<input type="checkbox"/>	
Contrôle du niveau du dispositif de lubrification de la vis	<input type="checkbox"/>		<input type="checkbox"/>		<input type="checkbox"/>		<input type="checkbox"/>		<input type="checkbox"/>		<input type="checkbox"/>	
Contrôle de la lubrification des glissières	<input type="checkbox"/>		<input type="checkbox"/>		<input type="checkbox"/>		<input type="checkbox"/>		<input type="checkbox"/>		<input type="checkbox"/>	
Contrôle de la présence et de l'emplacement des étiquettes adhésives	<input type="checkbox"/>		<input type="checkbox"/>		<input type="checkbox"/>		<input type="checkbox"/>		<input type="checkbox"/>		<input type="checkbox"/>	
Contrôle de l'intégrité des tampons de levage	<input type="checkbox"/>		<input type="checkbox"/>		<input type="checkbox"/>		<input type="checkbox"/>		<input type="checkbox"/>		<input type="checkbox"/>	
Capacité	<input type="checkbox"/>		<input type="checkbox"/>		<input type="checkbox"/>		<input type="checkbox"/>		<input type="checkbox"/>		<input type="checkbox"/>	
Recommandations	<input type="checkbox"/>		<input type="checkbox"/>		<input type="checkbox"/>		<input type="checkbox"/>		<input type="checkbox"/>		<input type="checkbox"/>	
Numéro de série	<input type="checkbox"/>		<input type="checkbox"/>		<input type="checkbox"/>		<input type="checkbox"/>		<input type="checkbox"/>		<input type="checkbox"/>	

ÍNDICE

CAP. 1	SIMBOLOGIA UTILIZZATA NEL MANUALE	ES_2
CAP. 2	PRESENTACIÓN.....	ES_3
2.1	DESCRIPCIÓN DEL ELEVADOR.....	ES_3
2.2	DESTINACIÓN DE USO.....	ES_3
CAP. 3	DATOS TÉCNICOS.....	ES_4
3.1	CARACTERÍSTICAS TÉCNICAS PRINCIPALES.....	ES_4
3.2	GENERAL TECHNICAL DETAILS.....	ES_5
3.3	DATOS DE IDENTIFICACION DE LA MAQUINA	ES_7
3.4	MANDOS PRINCIPALES DEL ELEVADOR	ES_8
3.5.	ESQUEMA ELECTRICO.....	ES_9
CAP. 4	NORMAS GENERALES DE SEGURIDAD.....	ES_17
4.1	INDICACIONES DE LOS RIESGOS RESIDUOS.....	ES_17
4.2	PLACAS Y/O ADHESIVOS DE SEGURIDAD.....	ES_17
4.3	FORMACIÓN DEL PERSONAL AUTORIZADO	ES_17
4.4	APTITUD PARA EL EMPLEO.....	ES_17
CAP. 5	REQUISITOS PARA LA INSTALACIÓN.....	ES_18
5.1	EXISTENCIA DE LOS REQUISITOS MÍNIMOS REQUERIDOS PARA EL SITIO DE LA INSTALACIÓN.....	ES_18
5.2	REQUISITOS DEL SUELO	ES_19
CAP. 6	DESPLAZAMIENTO Y PREINSTALACIÓN	ES_20
CAP. 7	INSTALACIÓN.....	ES_21
7.1	TACOS	ES_21
7.2	HORMIGÓN	ES_21
7.3	INSTRUCCIONES PARA LA INSTALACIÓN	ES_22
7.4	CONTROL DE TENSIÓN	ES_23
7.5	ENLACE A LA RED	ES_23
7.6	CONEXIONES.....	ES_23
7.7	TERMINACIÓN DE LA INSTALACIÓN Y CONTROL	ES_24
7.8	MONTAJE BRAZOS	ES_25
7.9	USO DE ACCESORIOS	ES_25
CAP. 8	USO DEL ELEVADOR.....	ES_26
8.1	PRECAUCIONES DURANTE EL USO.....	ES_26
8.2	DESPLAZAMIENTO Y COMPORTAMIENTO DURANTE LAS FUNCIONES DEL ELEVADOR.....	ES_26
8.3	IDENTIFICACIÓN DE LOS MANDOS Y SUS FUNCIONES	ES_27
8.4	USO IMPROPIO DEL ELEVADOR	ES_28
8.5	FUNCIONES DEL DISPOSITIVO DE CONTROL SINCRONIZACIÓN.....	ES_29
CAP. 9	DISPOSITIVOS DE SEGURIDAD	ES_31
CAP. 10	MANTENIMIENTO	ES_32
10.1	ACTIVIDAD DE MANTENIMIENTO	ES_32
10.2	DESGASTE TUERCA Y SUSTITUCIÓN GRUPO TORNILLO.....	ES_34
10.3	TROUBLE SHOOTING.....	ES_35
CAP. 11	ELIMINACIÓN-DESGUACE	ES_35
11.1	DESMONTAJE	ES_35
11.2	DESUSO.....	ES_35
11.3	ELIMINACIÓN.....	ES_35
	RELACIÓN DE INSTALACIÓN	ES_36
	CONTROL PERIÓDICO	ES_37
	MANTENIMIENTO EXTRAORDINARIO Y REPARACIONES	ES_38

¡ATENCIÓN!

- El presente manual constituye una parte integrante del producto, por lo que tendrá que seguir toda la vida operativa del elevador.
- Por lo tanto, guardarlo en un lugar conocido y fácilmente accesible para consultarlo cada vez que surjan dudas.
- El uso del elevador solo está permitido a personal debidamente capacitado, que haya leído y comprendido este manual.
- Cualquier daño que derive de la falta de respeto de las indicaciones que contiene el presente manual, o del uso incorrecto del elevador exime de toda responsabilidad a ROTARY.

CAP. 1 SIMBOLOGIA UTILIZZATA NEL MANUALE

	¡Atención		Obligatorio consultar el manual de instrucciones
	Peligro electricidad		Personal especializado
	Peligro cargas suspendidas		Obligación
	Peligro carretillas elevadoras y otros vehículos industriales		Prohibido pasar y detenerse debajo de cargas suspendidas
	Peligro piezas en movimiento		Usar calzado de seguridad
	Peligro aplastamiento manos		Usar los guantes
	Elevación desde arriba		Usar ropa de protección
	Prohibido		Usar las gafas
			Obligatorio desconectar antes de realizar mantenimientos o reparaciones

CAP. 2 PRESENTACIÓN

2.1 DESCRIPCIÓN DEL ELEVADOR

- Nombre producto: ELEVADOR PARA AUTOMÓVILES
- Descripción producto: Elevador electromecánico de dos columnas con brazos telescópicos. Puente para elevación del chasis

2.2 DESTINACIÓN DE USO

El producto está diseñado para la elevación de automóviles de acuerdo con las normas vigentes, Directiva de Máquinas 2006/42/CE; la capacidad de carga se indica en la placa matrícula.

El elevador está diseñado para ambientes interiores no sujetos a la acción del viento.

Está permitida la elevación de autovehículos que respondan a las siguientes características:

- peso no superior a la capacidad del elevador (ver fig. **A**) como exigido por la normativa UNI EN 1493:2010
- el elevador cumple con la división de la carga 2/5 – 3/5 y la condición de reversibilidad indicadas en la norma 1493:2010 (fig. **B**).
- distancia mínima de los puntos de elevación (carril): 1000 mm (fig. **C**).

Para valores de distancia inferiores, la capacidad del elevador se reduce. Por tanto, en esos casos y para otros no contemplados en el presente manual, será conveniente ponerse en contacto con el fabricante.

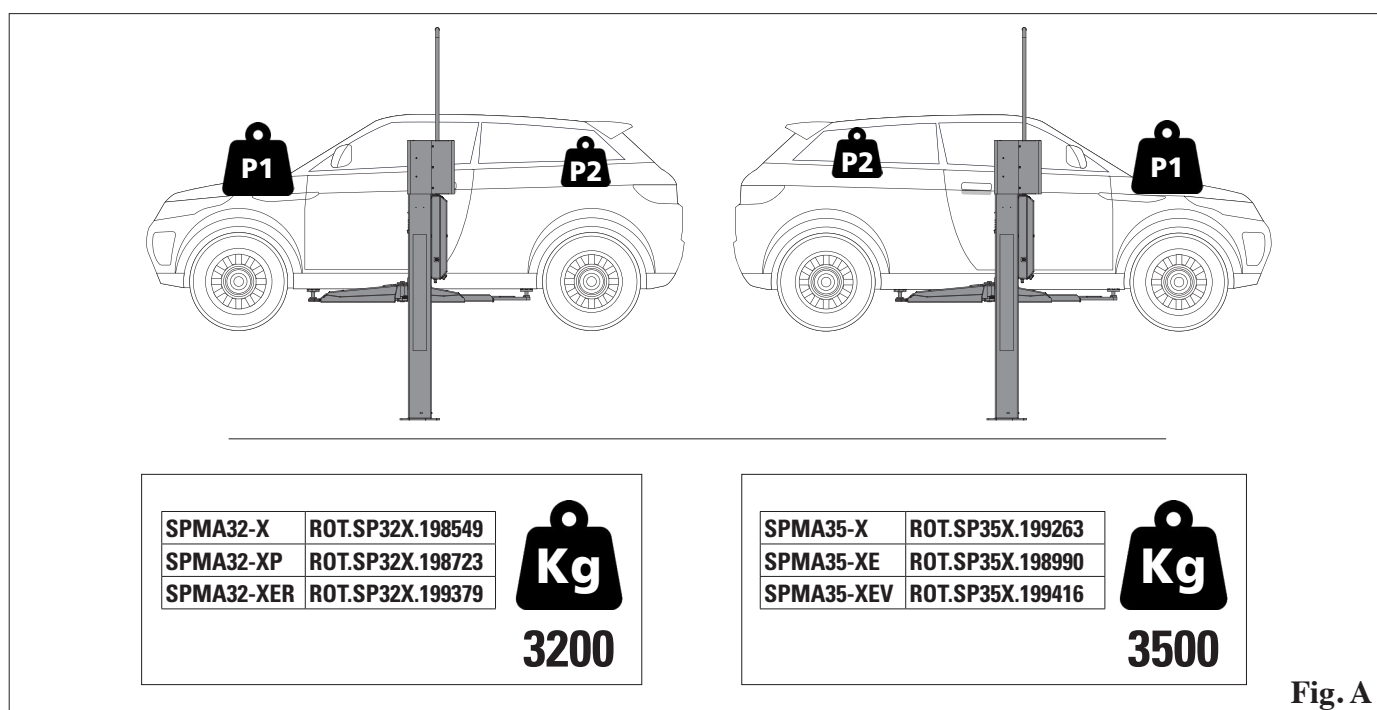

Fig. A

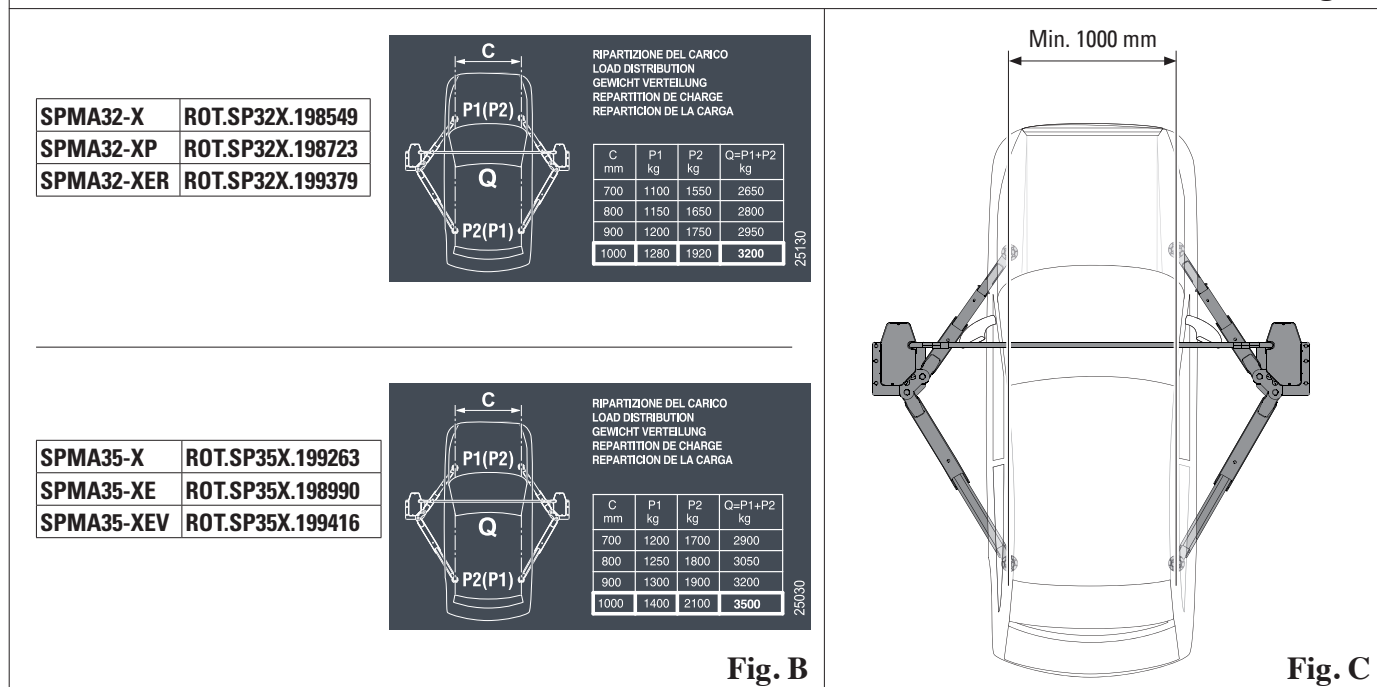

Fig. B

Fig. C

CAP. 3 DATOS TÉCNICOS

3.1 CARACTERÍSTICAS TÉCNICAS PRINCIPALES

Desplazamiento carros sobre patines de tecnopolímero de alta resistencia y bajo coeficiente de fricción.

Movimientos de elevación y descenso obtenidos por medio de tuercas portantes de bronce acopladas con tornillos de maniobra de paso hasta garantizar la irreversibilidad de los movimientos.

Dispositivo de seguridad electrónico que impide más carreras de elevación en caso de desgaste completo de la tuerca portante.

Lubricación automática de los tornillos de maniobra en cada carrera.

Alineación de los carros obtenida con dispositivo electrónico.

Dispositivo de bloqueo para desalineación de los carros que supere los **30 mm**.

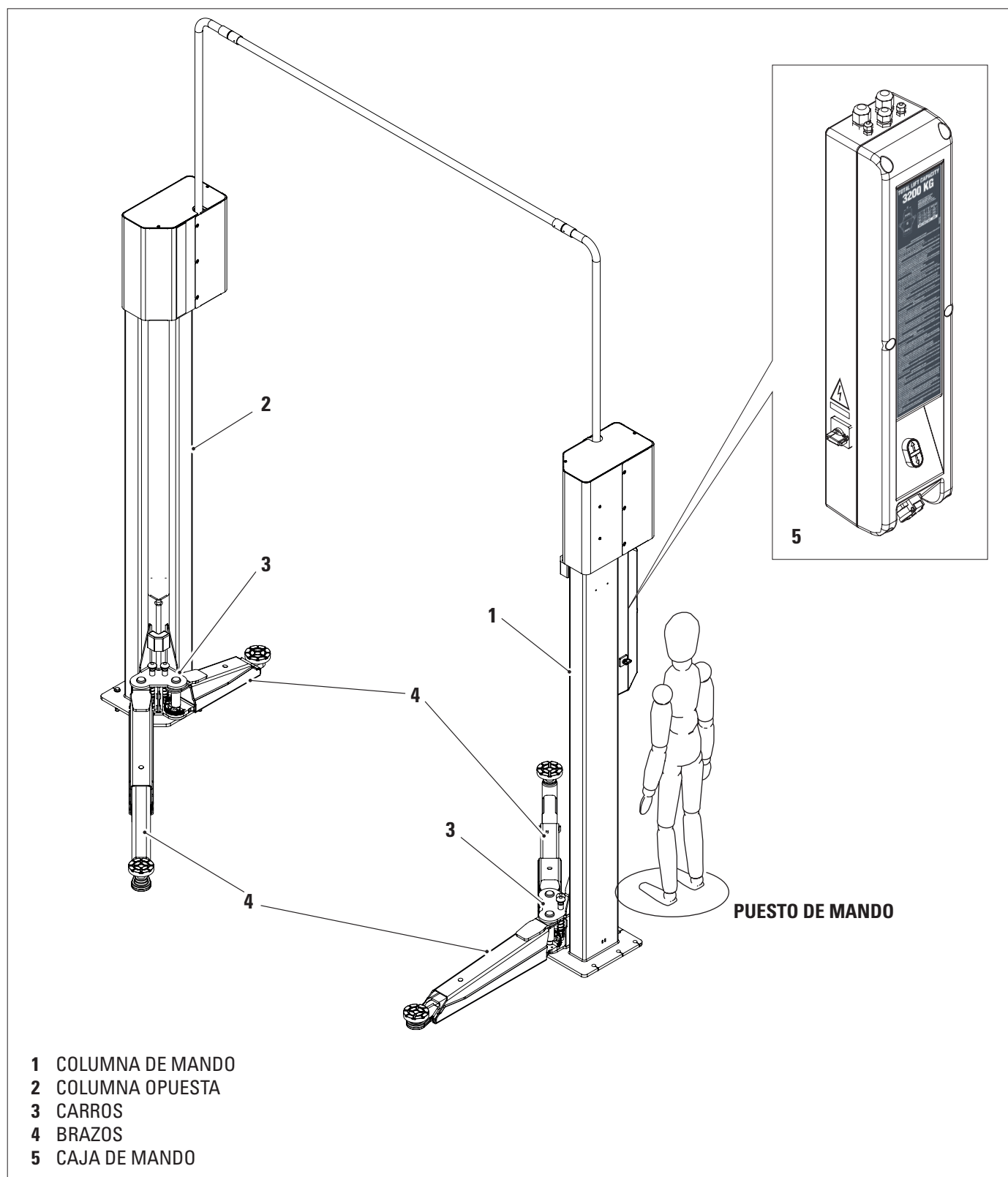

3.2 GENERAL TECHNICAL DETAILS
SPMA32

Número de columnas	2
Capacidad de elevación	3200 kg
Altura mínima techo	4150 mm
A Altura total	4052 mm
B Columnas externas	3223 mm
C Columnas internas	2700 mm

D Paso	2472 mm
Brazo Delantero Mín.	555 mm
Brazo Delantero Máx.	1100 mm
Brazo Trasero Mín.	805 mm
Brazo Trasero Máx.	1200 mm
E Altura máxima topes	130 mm
F Altura mínima topes	96 mm

Altura de elevación máxima	2000 mm
Elevación	1860 mm
Tiempo subida/bajada	42 secs.
Alimentación	400 V 50 Hz 3Ph
Potencia motriz	2x2.6 Kw

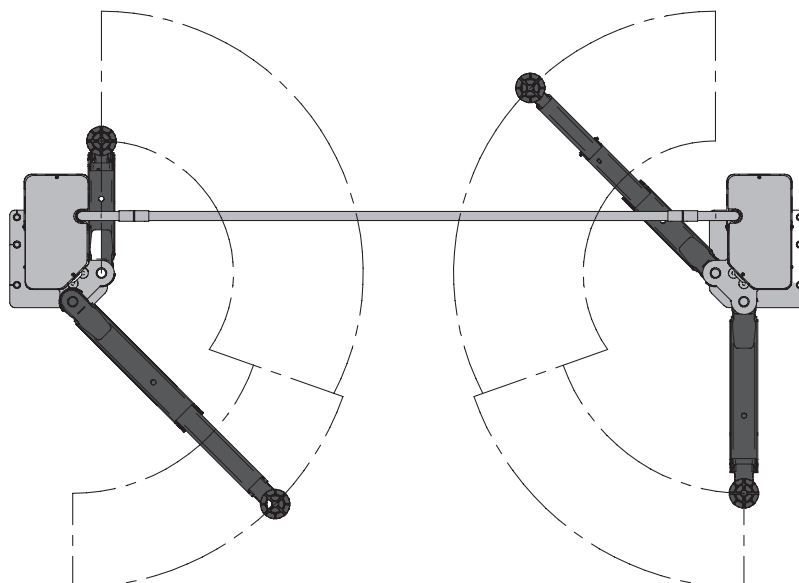
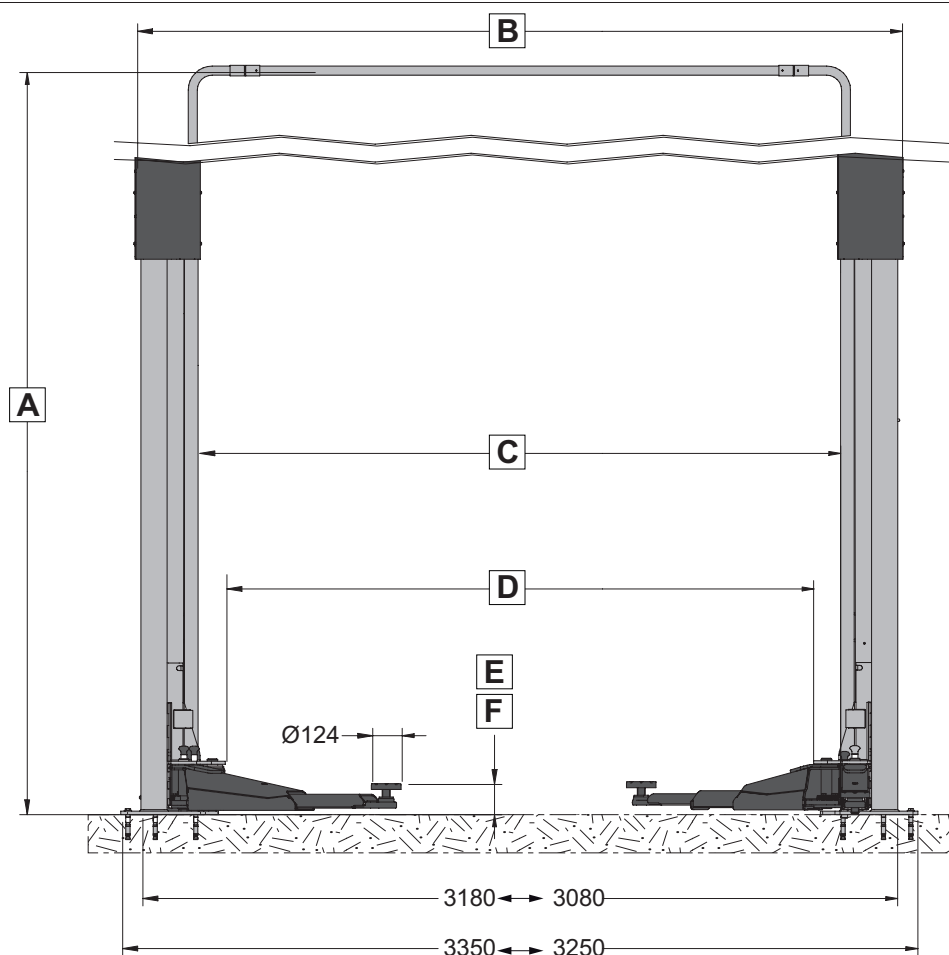

SPMA35

Número de columnas	2
Capacidad de elevación	3500 kg
Altura mínima techo	4150 mm
A Altura total	4052 mm
B Columnas externas	3223 mm
C Columnas internas	2700 mm

D Paso	2472 mm
Brazo Delantero Mín.	564 mm
Brazo Delantero Máx.	1160 mm
Brazo Trasero Mín.	922 mm
Brazo Trasero Máx.	1460 mm
E Altura máxima topes	150 mm
F Altura mínima topes	100 mm

Altura de elevación máxima	2012 mm
Elevación	1863 mm
Tiempo subida/bajada	42 secs.
Alimentación	400 V 50 Hz 3Ph
Potencia motriz	2x2.6 Kw

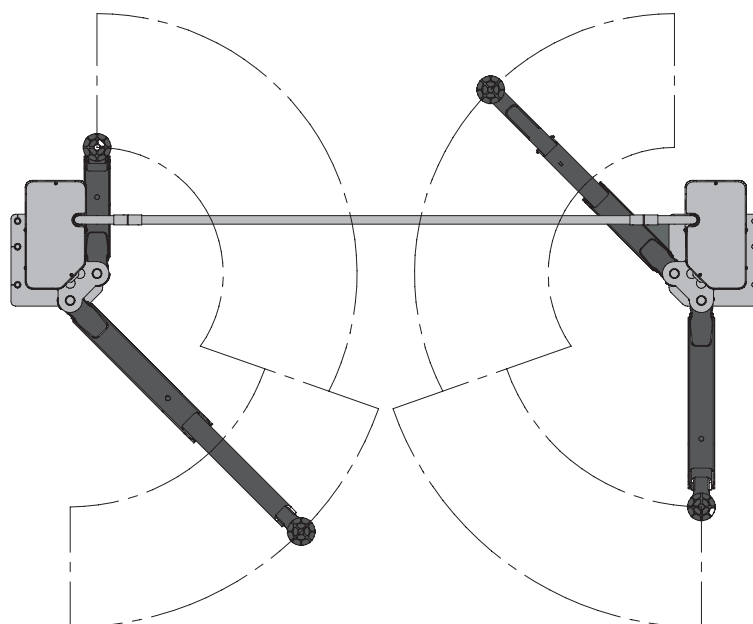
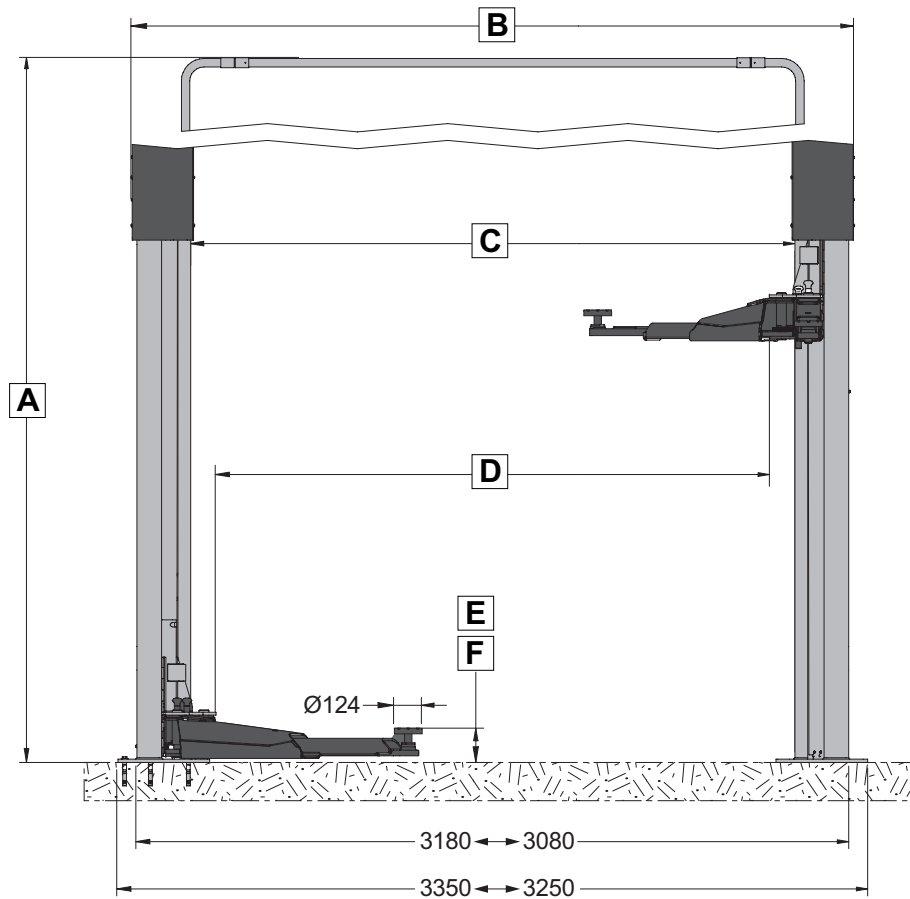

DATOS FONOMÉTRICOS
NIVEL DE RUIDO

	Ref	Distancia (m)	Lp dB(A)	Lpk dB(C)	U dB
	1	0,6	I 70dB(A)	I 130dB(C)	
2	1,0	73	I 130dB(C)		

3.3 DATOS DE IDENTIFICACION DE LA MAQUINA

En la carretilla de la columna de mando se encuentra la placa de identificación del elevador, que contiene los datos siguientes:

- A** Fabricante
- B** Capacidad elevador
- C** Número de matrícula
- D** Año de fabricación
- E** Modelo

ATENCIÓN: Se prohíbe terminantemente intervenir, grabar, alterar o extraer la tarjeta de identificación de la máquina; no cubran la tarjeta con tableros provisionales ya que debe resultar siempre visible.

Mantener dicha tarjeta siempre limpia, sin grasa ni suciedad en general.

ADVERTENCIA: En caso que, accidentalmente, la tarjeta de identificación resulte dañada (separada de la máquina, rota o ilegible aunque sea parcialmente) deberá notificarse inmediatamente a la empresa fabricante.

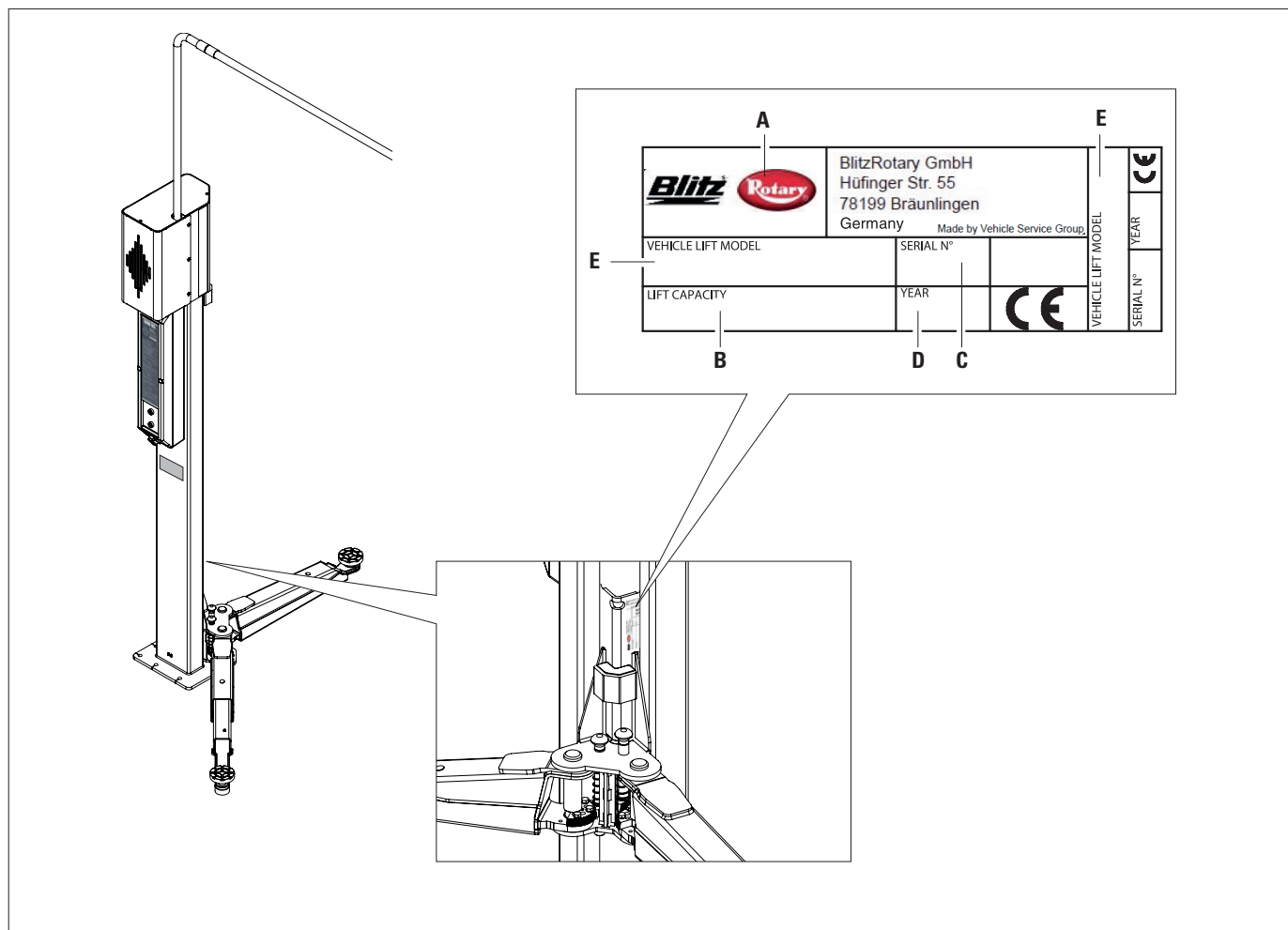

3.4 MANDOS PRINCIPALES DEL ELEVADOR

Los mandos principales se encuentran en la caja de mandos que cambia según el modelo. Ver esquema de comparación.

MODELO	CÓDIGO PN	CÓDIGO CAJA DE MANDOS	CÓDIGO CAJA DE DERIVACIÓN	CÓDIGO SISTEMA ELÉCTRICO
SPMA32-X	ROT.SP32X.198549	047303060	047303021	047305510
SPMA32-XP	ROT.SP32X.198723	047303070	047303080 (scatola comando)	047305530
SPMA32-XER	ROT.SP32X.199379	047303070	047303080 (scatola comando)	047305530
SPMA35-X	ROT.SP35X.199263	047303060	047303021	047305510
SPMA35-XE	ROT.SP35X.198990	047303070	047303080 (scatola comando)	047305530
SPMA35-XEV	ROT.SP35X.199416	047303070	047303080 (scatola comando)	047305530

047303060

Caja de mandos con interruptor y pulsadores ascenso y descenso.

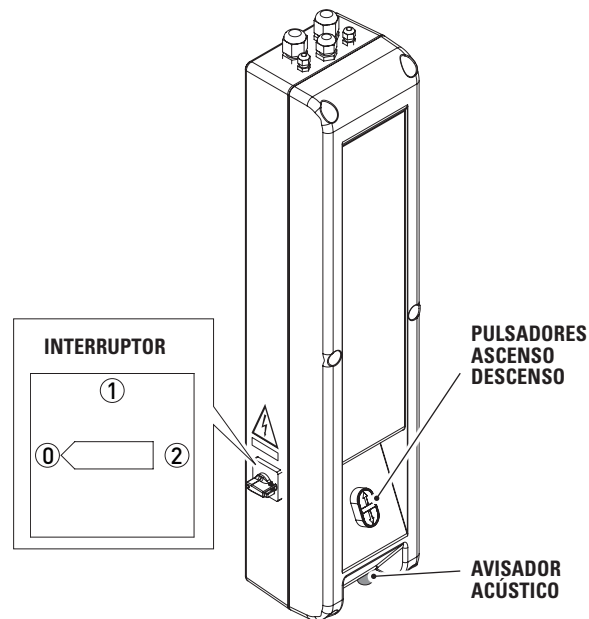
047303070 / 047303080

Doble caja de mandos con interruptor, pulsadores ascenso y descenso, pulsador de emergencia.

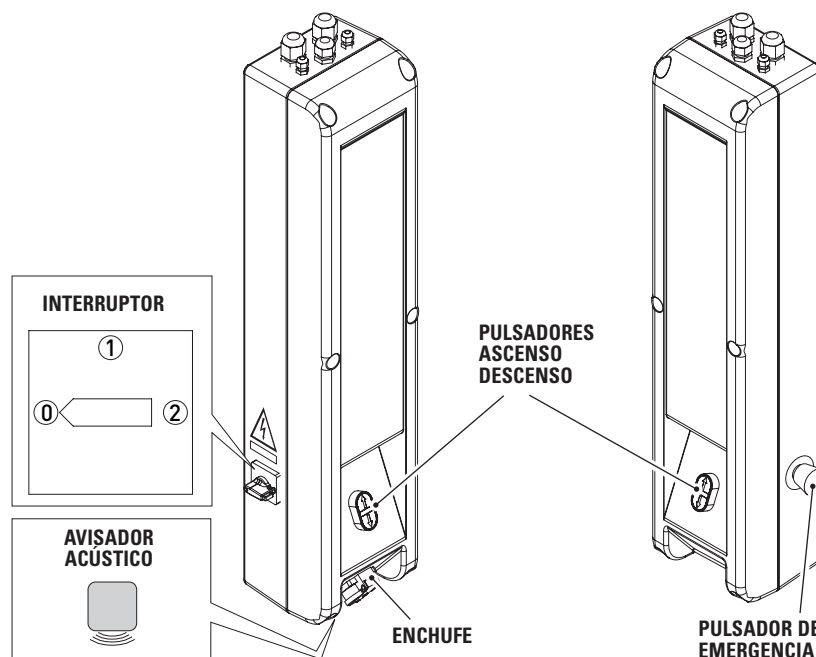

3.5. ESQUEMA ELECTRICO

La instalación tiene que efectuarla el utilizador

CÓDIGO SISTEMA ELÉCTRICO: 047305510

Alimentación eléctrica

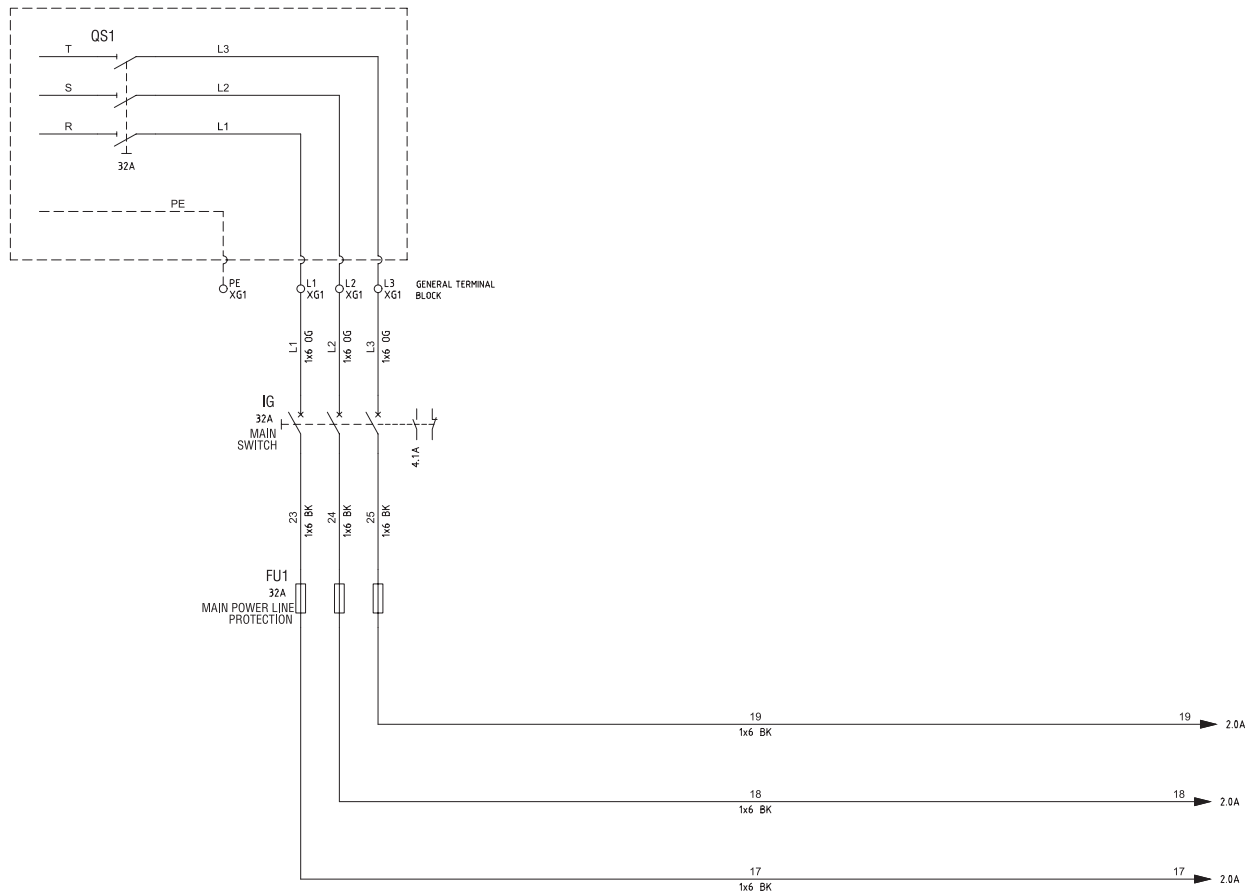

Alimentación motor

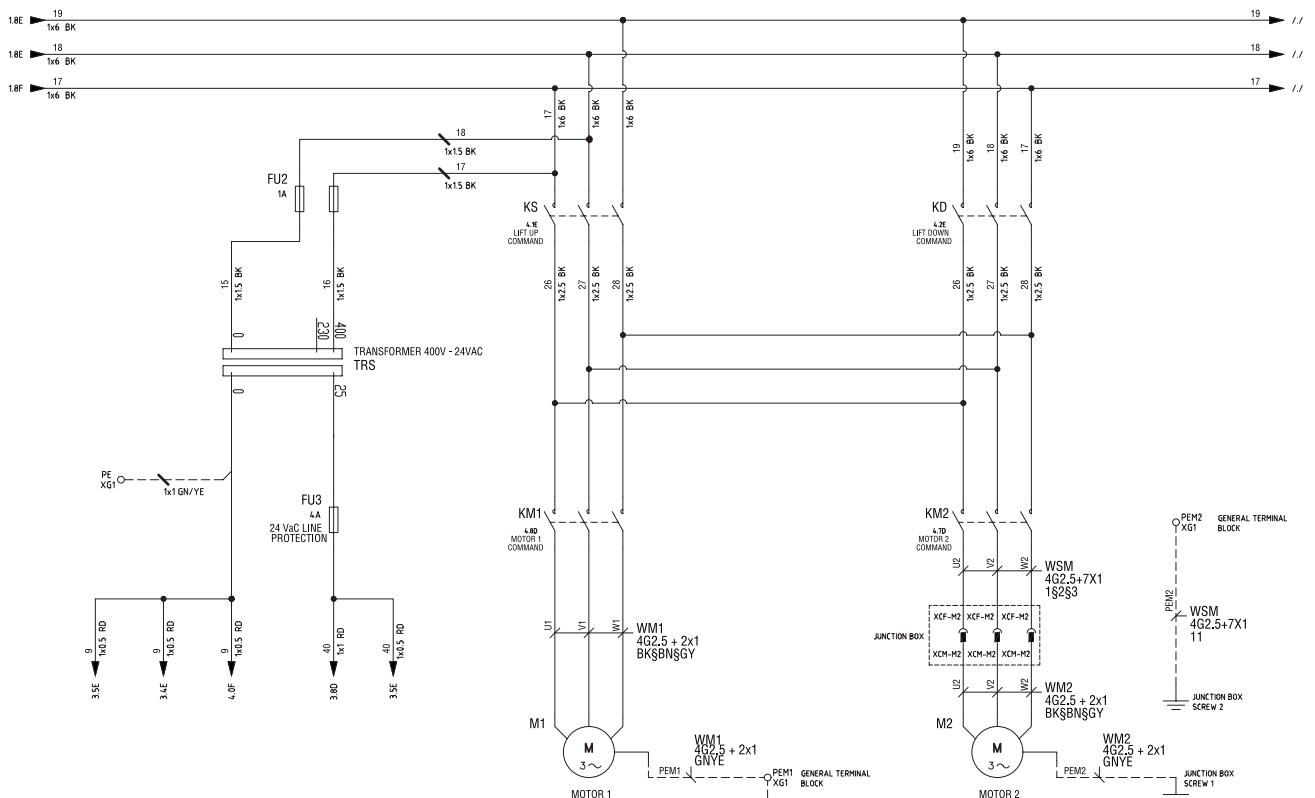

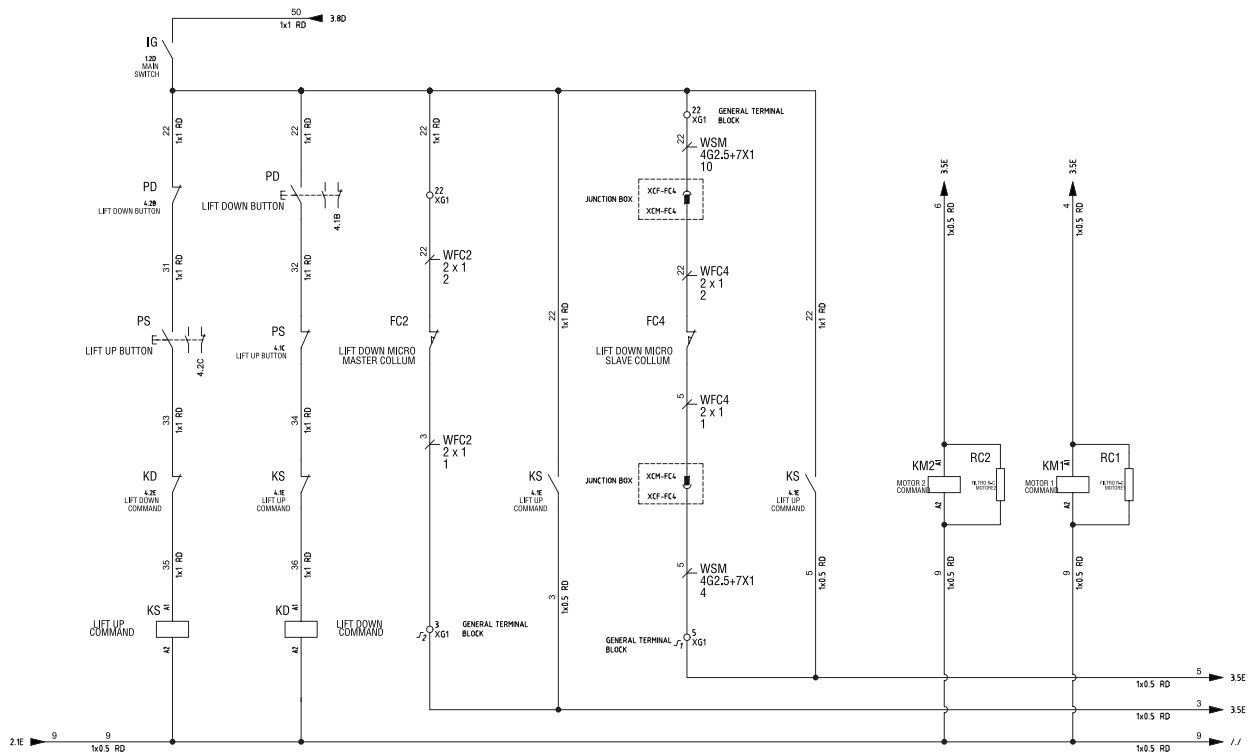
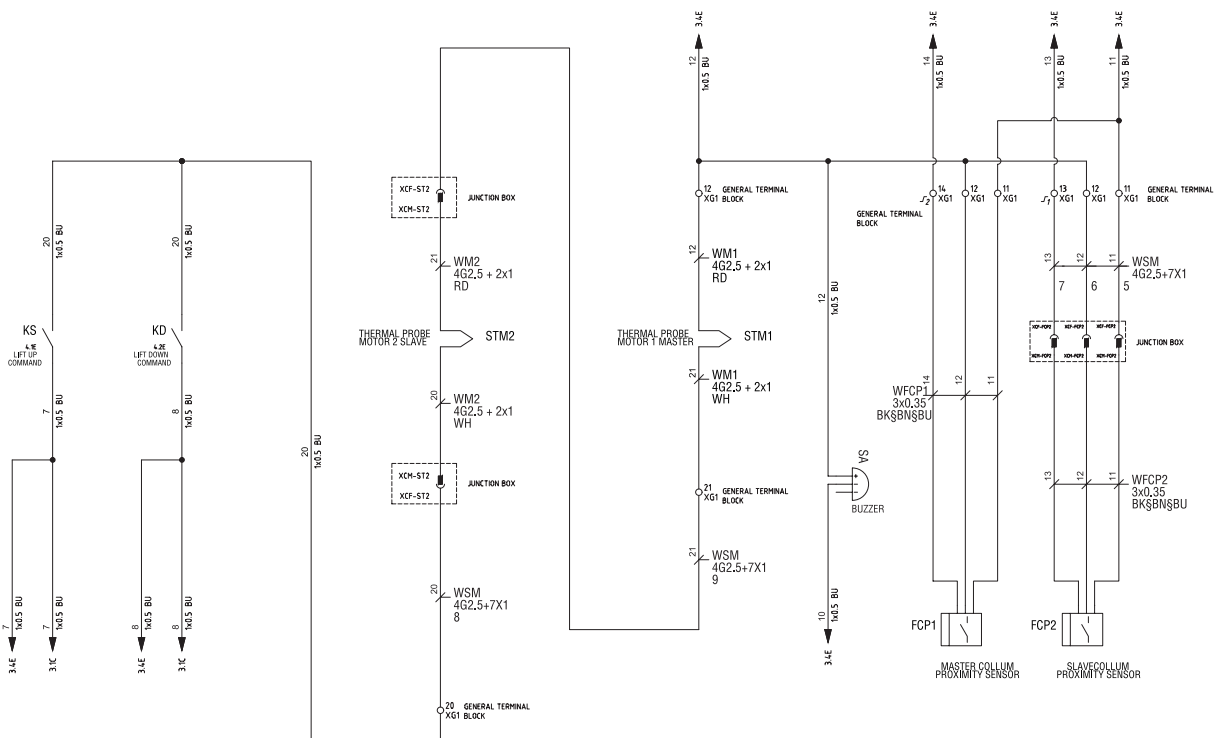
CÓDIGO SISTEMA ELÉCTRICO: 047305510
Señales de mando

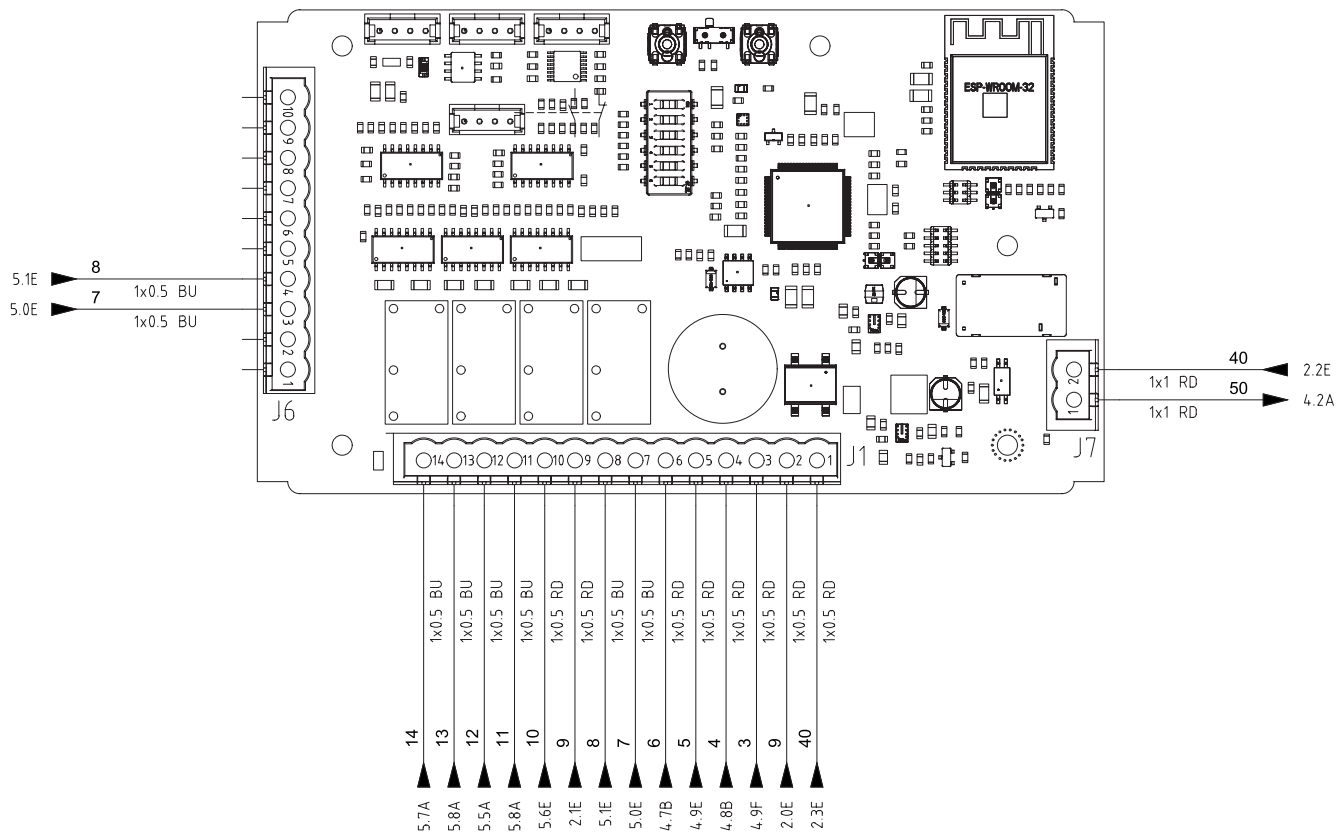
Señales

CÓDIGO SISTEMA ELÉCTRICO: 047305510
Señales tarjeta electrónica
KGR

CÓDIGO SISTEMA ELÉCTRICO: 047305510
Explicación

LISTA CROSS REFERENCE \ CROSS REFERENCE LIST							
Componente	Reference	Dati Tecnici	Technical Data	Componente	Reference	Dati Tecnici	Technical Data
		Nome\Item:M1	Quadro\Panel: +BM Fg.\Sh:2			Nome\Item:FU3	Quadro\Panel: +QG Fg.\Sh:2
		Tipo \ Type :				Tipo \ Type :	
		Costruttore \ Marke :				Costruttore \ Marke :	
		Descrizione \ Device :	Motore asincrono trifase			Descrizione \ Device :	PORTAFUSIBILE UNIPOLARE 1A 5X20 250V
		Funzione \ Use Type :	MOTOR 1 COMMAND COLLUM			Funzione \ Use Type :	24 Vac LINE PROTECTION
		Nome\Item:M2	Quadro\Panel: +BM Fg.\Sh:2			Nome\Item:IG	Quadro\Panel: +QG Fg.\Sh:1
		Tipo \ Type :				Tipo \ Type :	
		Costruttore \ Marke :				Costruttore \ Marke :	
		Descrizione \ Device :	Motore asincrono trifase			Descrizione \ Device :	INTERRUTTORE GENERALE 4 POLI + AUX, 32A
		Funzione \ Use Type :	MOTOR 2 SLAVE COLLUM			Funzione \ Use Type :	MAIN SWITCH
		Nome\Item:FC2	Quadro\Panel: +BM Fg.\Sh:4			Nome\Item:KD	Quadro\Board: +QG Fg.\Sh:4
		Tipo \ Type :				Tipo \ Type :	
		Costruttore \ Marke :				Costruttore \ Marke :	
		Descrizione \ Device :	Fine corsa NC			Descrizione \ Device :	TELERUTTORE COMADO DISCESA
		Funzione \ Use Type :	LIFT DOWN MICRO MASTER COLLUM			Funzione \ Use Type :	LIFT DOWN COMMAND
		Nome\Item:FC4	Quadro\Panel: +BM Fg.\Sh:4			Nome\Item:KM1	Quadro\Panel: +QG Fg.\Sh:4
		Tipo \ Type :				Tipo \ Type :	
		Costruttore \ Marke :				Costruttore \ Marke :	
		Descrizione \ Device :	Fine corsa NC			Descrizione \ Device :	TELERUTTORE COMANDO MOTORE 1
		Funzione \ Use Type :	LIFT DOWN MICRO SLAVE COLLUM			Funzione \ Use Type :	MOTOR 1 COMMAND
		Nome\Item:FU1	Quadro\Panel: +QG Fg.\Sh:1			Nome\Item:KM2	Quadro\Panel: +QG Fg.\Sh:4
		Tipo \ Type :				Tipo \ Type :	
		Costruttore \ Marke :				Costruttore \ Marke :	
		Descrizione \ Device :	PORTAFUS, TRIPOLARE 10X38 WIMEX 32A 500V			Descrizione \ Device :	TELERUTTORE COMANDO MOTORE 2
		Funzione \ Use Type :	MAIN POWER LINE PROTECTION			Funzione \ Use Type :	MOTOR 2 COMMAND
		Nome\Item:FU2	Quadro\Panel: +QG Fg.\Sh:2			Nome\Item:KS	Quadro\Panel: +QG Fg.\Sh:4
		Tipo \ Type :				Tipo \ Type :	
		Costruttore \ Marke :				Costruttore \ Marke :	
		Descrizione \ Device :	PORTAFUS, BIPOLARE 10X38 WIMEX 1A 500V			Descrizione \ Device :	TELERUTTORE COMANDO SALITA
		Funzione \ Use Type :	TRANSFORMER POWER LINE PROTECTION			Funzione \ Use Type :	LIFT UP COMMAND

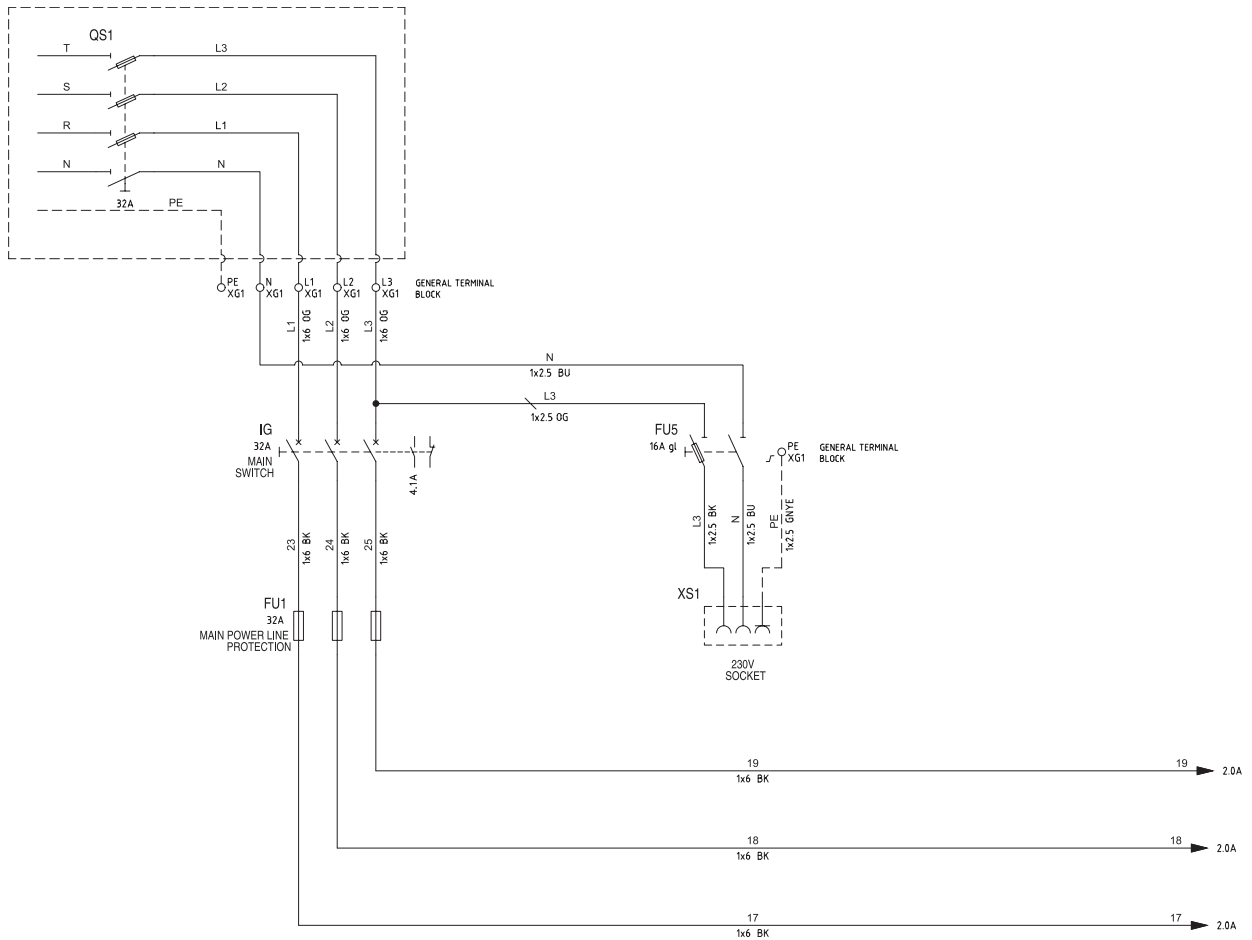
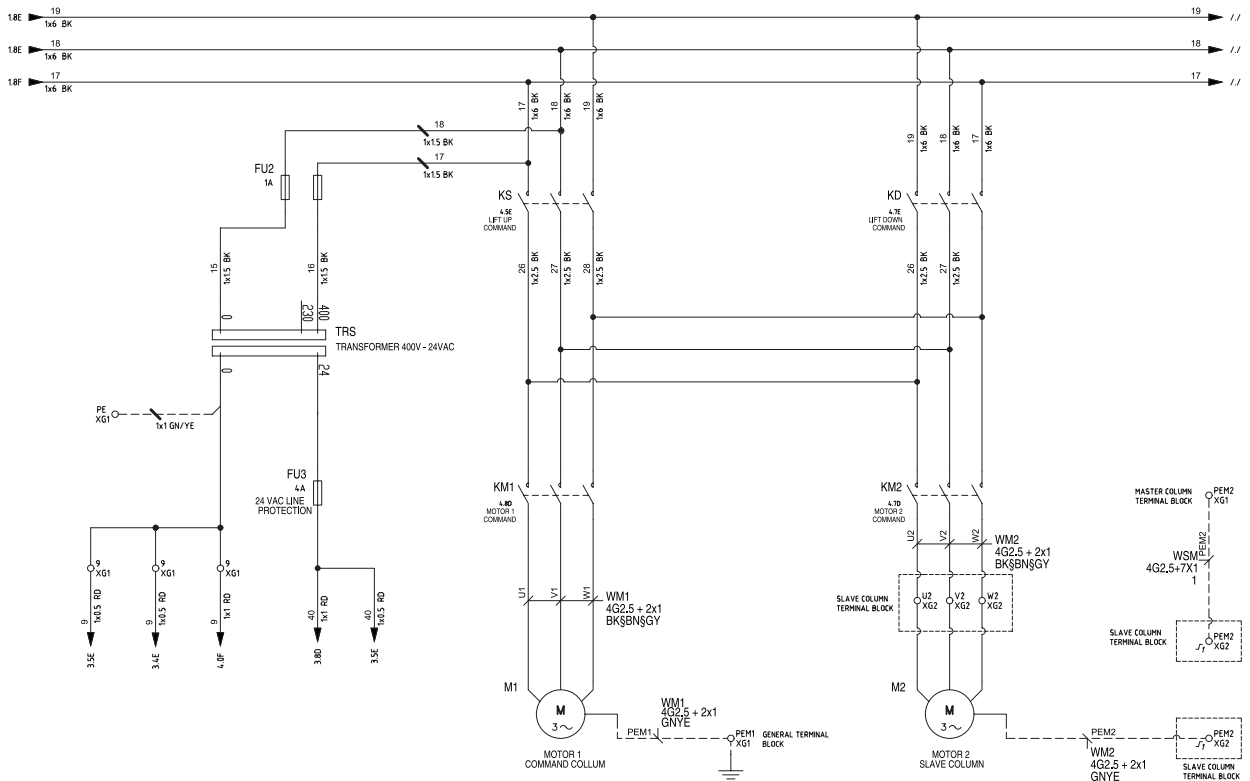
LISTA CROSS REFERENCE \ CROSS REFERENCE LIST							
Componente	Reference	Dati Tecnici	Technical Data	Componente	Reference	Dati Tecnici	Technical Data
		Nome\Item:PD	Quadro\Panel: +QG Fg.\Sh:4			Nome\Item:FCP1	Quadro\Panel: +BM Fg.\Sh:5
		Tipo \ Type :				Tipo \ Type :	
		Costruttore \ Marke :				Costruttore \ Marke :	
		Descrizione \ Device :	PULSANTE DISCESA			Descrizione \ Device :	INTERRUTTORE DI PROSSIMITA'
		Funzione \ Use Type :	LIFT DOWN BUTTON			Funzione \ Use Type :	PROXIMITY SENSOR
		Nome\Item:PS	Quadro\Panel: +QG Fg.\Sh:4			Nome\Item:FCP2	Quadro\Panel: +BM Fg.\Sh:5
		Tipo \ Type :				Tipo \ Type :	
		Costruttore \ Marke :				Costruttore \ Marke :	
		Descrizione \ Device :	PULSANTE DISCESA			Descrizione \ Device :	INTERRUTTORE DI PROSSIMITA'
		Funzione \ Use Type :	LIFT UP BUTTON			Funzione \ Use Type :	PROXIMITY SENSOR
		Nome\Item:QS1	Quadro\Panel: +QG Fg.\Sh:1			Nome\Item:KGR	Quadro\Board: +QG Fg.\Sh:3
		Tipo \ Type :				Tipo \ Type :	
		Costruttore \ Marke :				Costruttore \ Marke :	
		Descrizione \ Device :	INTERRUTTORE GENERALE CLIENTE 32A			Descrizione \ Device :	SCHEDA ELETTRONICA
		Funzione \ Use Type :	CLIENT POWER MAIN SWITCH			Funzione \ Use Type :	ELECTRONIC BOARD
		Nome\Item:RC1	Quadro\Panel: +QG Fg.\Sh:4			Nome\Item:STM1	Quadro\Panel: +BM Fg.\Sh:5
		Tipo \ Type :				Tipo \ Type :	
		Costruttore \ Marke :				Costruttore \ Marke :	
		Descrizione \ Device :	FILTRO ANTIDISTURBI R-C			Descrizione \ Device :	SONDA TERMICA
		Funzione \ Use Type :	FILTRO R-C MOTORE1			Funzione \ Use Type :	THERMAL PROBE MOTOR 1 MASTER
		Nome\Item:RC2	Quadro\Panel: +QG Fg.\Sh:4			Nome\Item:STM2	Quadro\Panel: +BM Fg.\Sh:5
		Tipo \ Type :				Tipo \ Type :	
		Costruttore \ Marke :				Costruttore \ Marke :	
		Descrizione \ Device :	FILTRO ANTIDISTURBI R-C			Descrizione \ Device :	SONDA TERMICA
		Funzione \ Use Type :	FILTRO R-C MOTORE2			Funzione \ Use Type :	THERMAL PROBE MOTOR 2 SLAVE
		Nome\Item:SA	Quadro\Panel: +QG Fg.\Sh:5			Nome\Item:TRS	Quadro\Panel: +QG Fg.\Sh:2
		Tipo \ Type :				Tipo \ Type :	
		Costruttore \ Marke :				Costruttore \ Marke :	
		Descrizione \ Device :	AVVISATORE ACUSTICO			Descrizione \ Device :	TRASFORMATORE 100 V/A
		Funzione \ Use Type :	BUZZER			Funzione \ Use Type :	TRANSFORMER 400V - 24VAC

CÓDIGO SISTEMA ELÉCTRICO: 047305530
Alimentación eléctrica

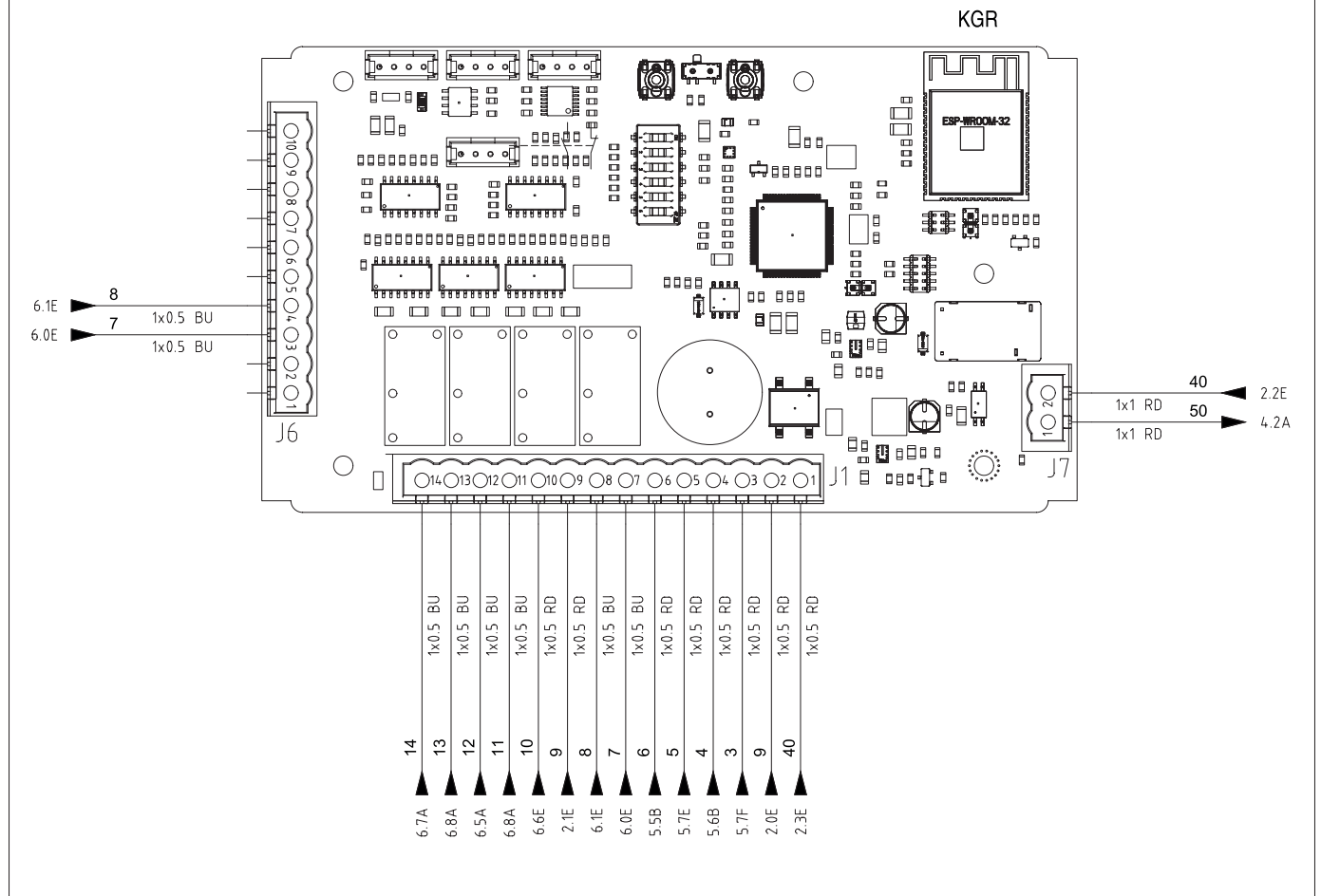
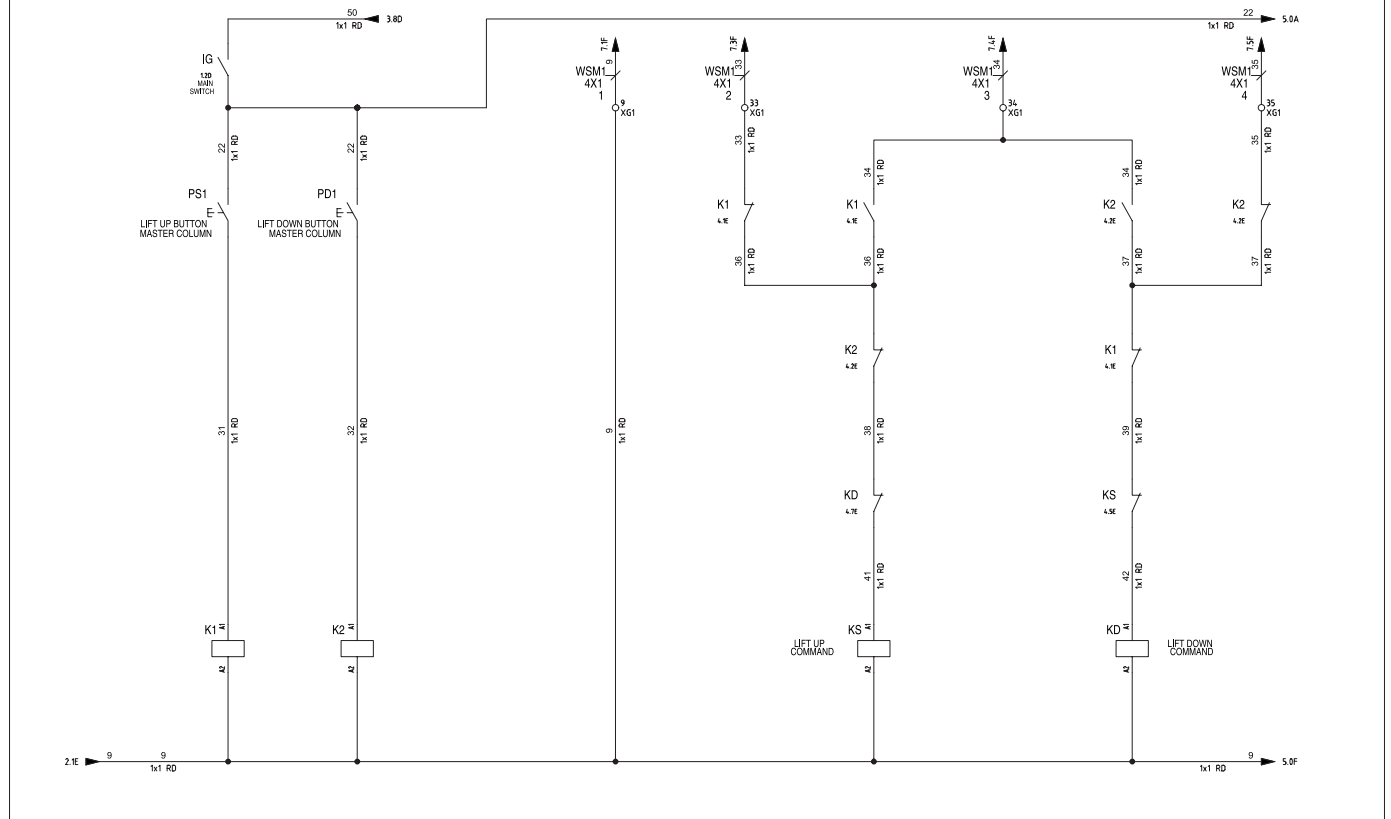
Alimentación motor

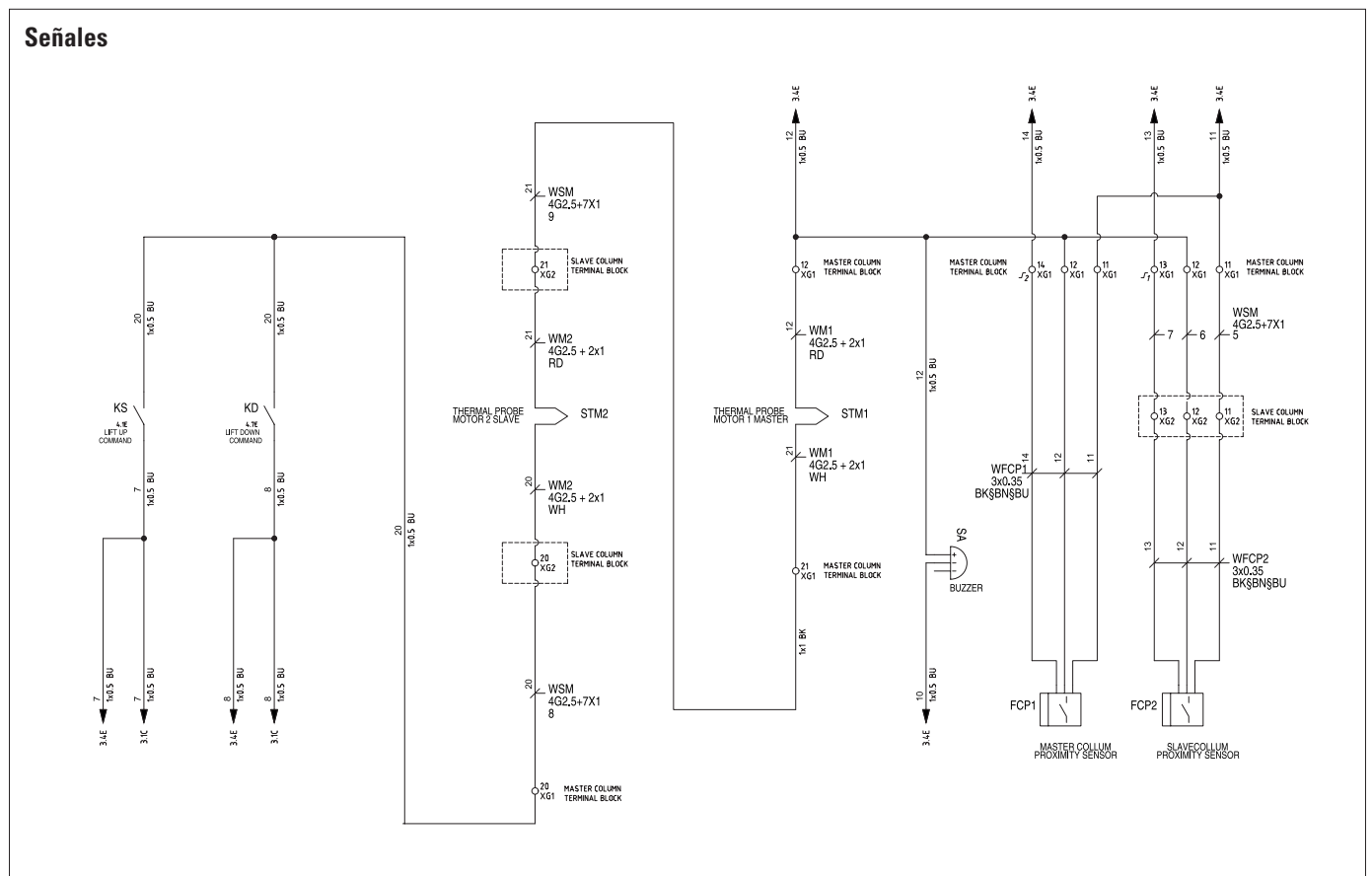
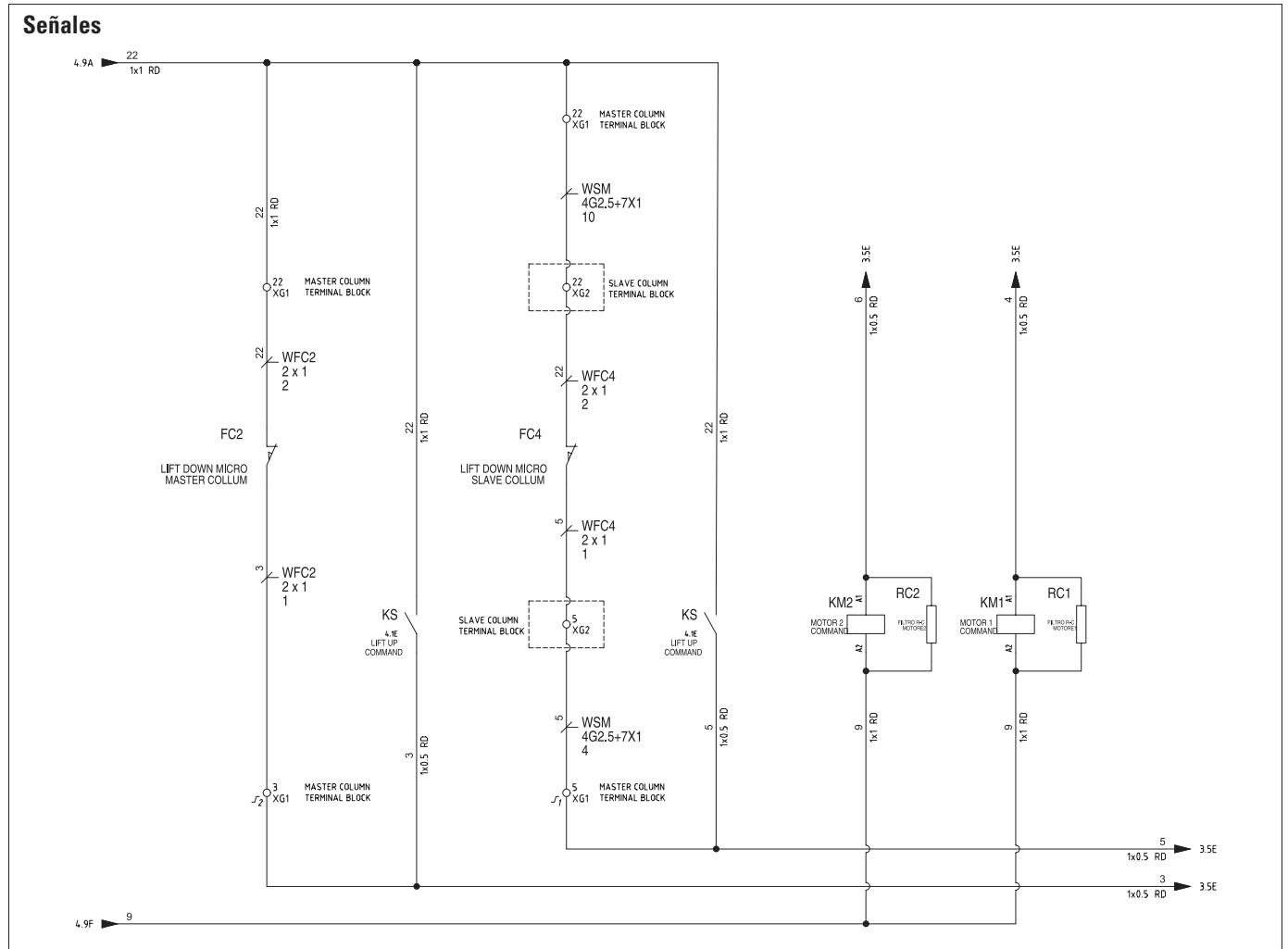
CÓDIGO SISTEMA ELÉCTRICO: 047305530
Señales tarjeta electrónica

Señales de mando

CÓDIGO SISTEMA ELÉCTRICO: 047305530

CÓDIGO SISTEMA ELÉCTRICO: 047305530
Explicación

LISTA CROSS REFERENCE \ CROSS REFERENCE LIST							
Componente	Reference	Dati Tecnici	Technical Data	Componente	Reference	Dati Tecnici	Technical Data
		Nome\Item:M1	Quadro\Panel: +BM Fg.\Sh.:2			Nome\Item:FU3	Quadro\Panel: +QG Fg.\Sh.:2
		Tipo \ Type : Costruttore \ Marke: Descrizione \ Device : Motore asincrono trifase Funzione \ Use Type : MOTOR 1 COMMAND COLLUM				Tipo \ Type : Costruttore \ Marke: Descrizione \ Device : PORTAFUSIBILE UNIPOLARE 1A 5X20 250V Funzione \ Use Type : 24 VaC LINE PROTECTION	
		Nome\Item:M2	Quadro\Panel: +BM Fg.\Sh.:2			Nome\Item:IG	Quadro\Panel: +QG Fg.\Sh.:1
		Tipo \ Type : Costruttore \ Marke: Descrizione \ Device : Motore asincrono trifase Funzione \ Use Type : SLAVE COLUMN				Tipo \ Type : Costruttore \ Marke: Descrizione \ Device : INTERRUTTORE GENERALE 4 POLI + AUX. 32A Funzione \ Use Type : MAIN SWITCH	
		Nome\Item:FC2	Quadro\Panel: +BM Fg.\Sh.:4			Nome\Item:KD	Quadro\Board: +QG Fg.\Sh.:4
		Tipo \ Type : Costruttore \ Marke: Descrizione \ Device : Fine corsa NC Funzione \ Use Type : LIFT DOWN MICRO MASTER COLLUM				Tipo \ Type : Costruttore \ Marke: Descrizione \ Device : TELERUTTORE COMADO DISCESA Funzione \ Use Type : LIFT DOWN COMMAND	
		Nome\Item:FC4	Quadro\Panel: +BM Fg.\Sh.:4			Nome\Item:KM1	Quadro\Panel: +QG Fg.\Sh.:4
		Tipo \ Type : Costruttore \ Marke: Descrizione \ Device : Fine corsa NC Funzione \ Use Type : LIFT DOWN MICRO SLAVE COLLUM				Tipo \ Type : Costruttore \ Marke: Descrizione \ Device : TELERUTTORE COMANDO MOTORE 1 Funzione \ Use Type : MOTOR 1 COMMAND	
		Nome\Item:FU1	Quadro\Panel: +QG Fg.\Sh.:1			Nome\Item:KM2	Quadro\Panel: +QG Fg.\Sh.:4
		Tipo \ Type : Costruttore \ Marke: Descrizione \ Device : PORTAFUS. TRIPOLARE 10X38 WIMEX 32A 500V Funzione \ Use Type : MAIN POWER LINE PROTECTION				Tipo \ Type : Costruttore \ Marke: Descrizione \ Device : TELERUTTORE COMANDO MOTORE 2 Funzione \ Use Type : MOTOR 2 COMMAND	
		Nome\Item:FU2	Quadro\Panel: +QG Fg.\Sh.:2			Nome\Item:KS	Quadro\Panel: +QG Fg.\Sh.:4
		Tipo \ Type : Costruttore \ Marke: Descrizione \ Device : PORTAFUS. BIPOLARE 10X38 WIMEX 1A 500V Funzione \ Use Type : TRANSFORMER POWER LINE PROTECTION				Tipo \ Type : Costruttore \ Marke: Descrizione \ Device : TELERUTTORE COMANDO SALITA Funzione \ Use Type : LIFT UP COMMAND	

LISTA CROSS REFERENCE \ CROSS REFERENCE LIST							
Componente	Reference	Dati Tecnici	Technical Data	Componente	Reference	Dati Tecnici	Technical Data
		Nome\Item:PD	Quadro\Panel: +QG Fg.\Sh.:4			Nome\Item:FCP1	Quadro\Panel: +BM Fg.\Sh.:5
		Tipo \ Type : Costruttore \ Marke: Descrizione \ Device : PULSANTE DISCESA Funzione \ Use Type : LIFT DOWN BUTTON				Tipo \ Type : Costruttore \ Marke: Descrizione \ Device : INTERRUTTORE DI PROSSIMITA' Funzione \ Use Type : PROXIMITY SENSOR	
		Nome\Item:PS	Quadro\Panel: +QG Fg.\Sh.:4			Nome\Item:FCP2	Quadro\Panel: +BM Fg.\Sh.:5
		Tipo \ Type : Costruttore \ Marke: Descrizione \ Device : PULSANTE DISCESA Funzione \ Use Type : LIFT UP BUTTON				Tipo \ Type : Costruttore \ Marke: Descrizione \ Device : INTERRUTTORE DI PROSSIMITA' Funzione \ Use Type : PROXIMITY SENSOR	
		Nome\Item:QS1	Quadro\Panel: +QG Fg.\Sh.:1			Nome\Item:KGR	Quadro\Board: +QG Fg.\Sh.:3
		Tipo \ Type : Costruttore \ Marke: Descrizione \ Device : INTERRUTTORE GENERALE CLIENTE 32A Funzione \ Use Type : CLIENT POWER MAIN SWITCH				Tipo \ Type : Costruttore \ Marke: Descrizione \ Device : SCHEDA ELETTRONICA Funzione \ Use Type : ELECTRONIC BOARD	
		Nome\Item:RC1	Quadro\Panel: +QG Fg.\Sh.:4			Nome\Item:STM1	Quadro\Panel: +BM Fg.\Sh.:5
		Tipo \ Type : Costruttore \ Marke: Descrizione \ Device : FILTRO ANTIDISTURBI R-C Funzione \ Use Type : MOTORE1				Tipo \ Type : Costruttore \ Marke: Descrizione \ Device : SONDA TERMICA Funzione \ Use Type : THERMAL PROBE MOTOR 1 MASTER	
		Nome\Item:RC2	Quadro\Panel: +QG Fg.\Sh.:4			Nome\Item:STM2	Quadro\Panel: +BM Fg.\Sh.:5
		Tipo \ Type : Costruttore \ Marke: Descrizione \ Device : FILTRO ANTIDISTURBI R-C Funzione \ Use Type : MOTORE2				Tipo \ Type : Costruttore \ Marke: Descrizione \ Device : SONDA TERMICA Funzione \ Use Type : THERMAL PROBE MOTOR 2 SLAVE	
		Nome\Item:SA	Quadro\Panel: +QG Fg.\Sh.:5			Nome\Item:TRS	Quadro\Panel: +QG Fg.\Sh.:2
		Tipo \ Type : Costruttore \ Marke: Descrizione \ Device : AVVISATORE ACUSTICO Funzione \ Use Type : BUZZER				Tipo \ Type : Costruttore \ Marke: Descrizione \ Device : TRASFORMATORE 100 V/A Funzione \ Use Type : TRANSFORMER 400V - 24VAC	
		Nome\Item: FU5	Quadro\Panel: +QG Fg.\Sh.:1			Nome\Item:	Quadro\Panel: Fg.\Sh.:
		Tipo \ Type : Costruttore \ Marke: Descrizione \ Device : Funzione \ Use Type :PROTEZIONE LINA 230V PRESA				Tipo \ Type : Costruttore \ Marke: Descrizione \ Device : Funzione \ Use Type :	
		Nome\Item: XS1	Quadro\Panel: +QG Fg.\Sh.:1			Nome\Item:	Quadro\Panel: Fg.\Sh.:
		Tipo \ Type : Costruttore \ Marke: Descrizione \ Device : PRESA 230V Funzione \ Use Type :				Tipo \ Type : Costruttore \ Marke: Descrizione \ Device : Funzione \ Use Type :	

CAP. 4 NORMAS GENERALES DE SEGURIDAD

4.1 INDICACIONES DE LOS RIESGOS RESIDUOS

Nuestro elevador se ha construido aplicando normas severas para responder a los requisitos exigidos por las normativas pertinentes. El análisis de los riesgos se efectuó con el máximo cuidado y los peligros fueron, en lo que fue posible, eliminados. Eventuales riesgos residuos se evidencian en el presente manual y en la máquina mediante pictogramas de CUIDADO.

4.2 PLACAS Y/O ADHESIVOS DE SEGURIDAD

En el elevador están presentes placas y adhesivos necesarios para la identificación de la máquina, la capacidad de carga, las instrucciones y el sistema eléctrico.

En el caso de que estos pictogramas se estropeen, es necesario sustituirlos, solicitándolos a la Empresa ROTARY

4.3 FORMACIÓN DEL PERSONAL AUTORIZADO

El uso del elevador está sólo permitido al personal que haya sido instruido y que esté autorizado.

Para que el manejo de la máquina sea el óptimo y se puedan efectuar las operaciones con eficacia, es necesario que se instruya al personal autorizado de manera correcta para aprender las informaciones necesarias con el fin de alcanzar un modo de trabajar en línea con las indicaciones que da el constructor.

Para cualquier duda relativa al uso y al mantenimiento de la máquina, consultar el manual de instrucciones y si fuera necesario ponerse en contacto con los centros de asistencia autorizados o la asistencia técnica ROTARY.

4.4 APTITUD PARA EL EMPLEO

Este producto ha sido fabricado de conformidad con la Directiva Europea 2006/42/CE. En virtud del artículo 4.1.2.3 (Alegado 1) de dicha Directiva, los coeficientes utilizados para las pruebas son los siguientes:

1.10 para la prueba dinámica

1.25 para la prueba estática

Estas pruebas tienen que ser efectuadas por personal especializado.

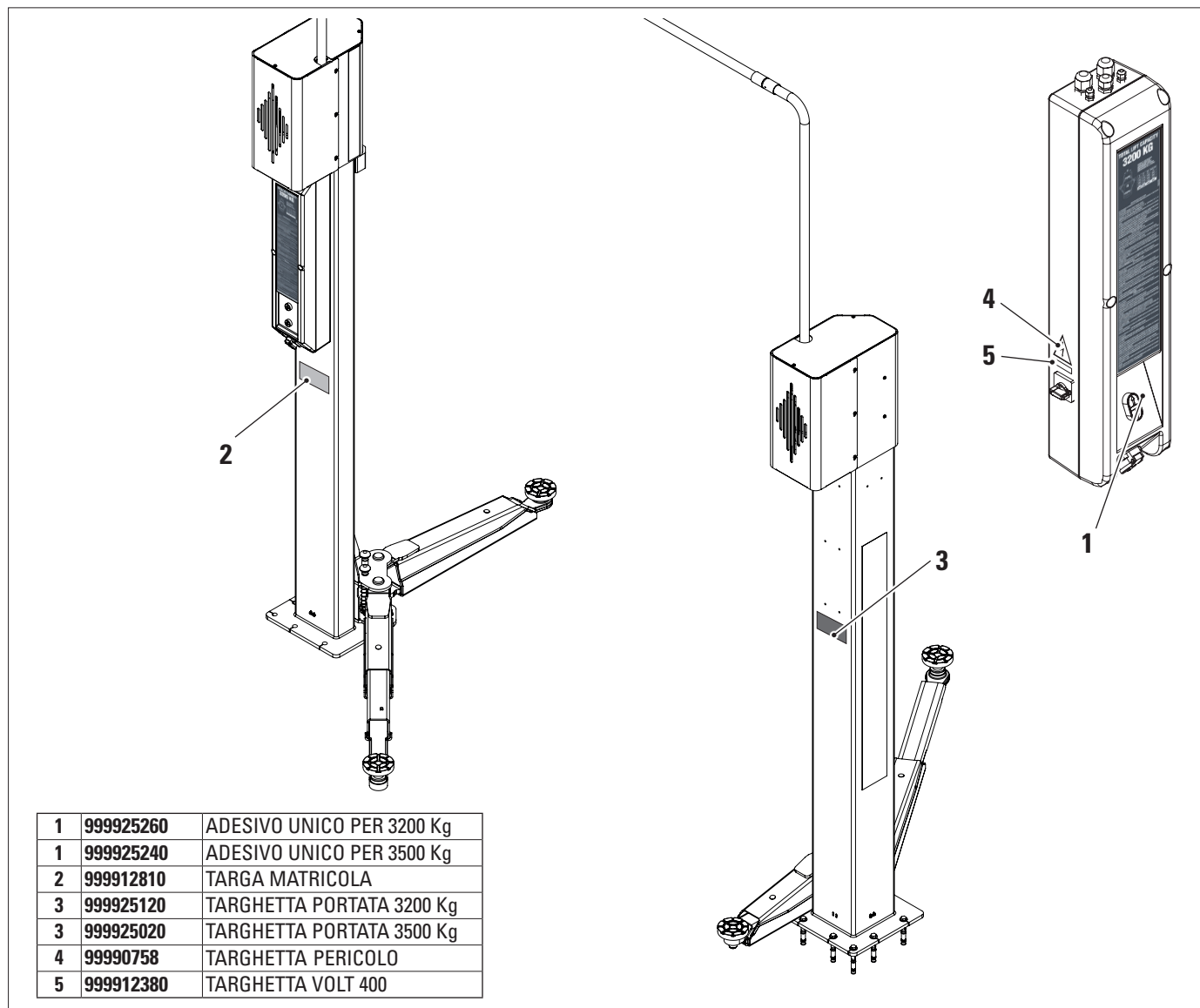

1	999925260	ADESIVO UNICO PER 3200 Kg
1	999925240	ADESIVO UNICO PER 3500 Kg
2	999912810	TARGA MATRICOLA
3	999925120	TARGHETTA PORTATA 3200 Kg
3	999925020	TARGHETTA PORTATA 3500 Kg
4	99990758	TARGHETTA PERICOLO
5	999912380	TARGHETTA VOLT 400

CAP. 5 REQUISITOS PARA LA INSTALACIÓN

5.1 EXISTENCIA DE LOS REQUISITOS MÍNIMOS REQUERIDOS PARA EL SITIO DE LA INSTALACIÓN

Asegurarse de que lugar donde se instalará la máquina cumpla las siguientes características:

- el uso del elevador solo está permitido en entornos cerrados, donde no hay peligro de explosión o incendio.
- el elevador no es adecuado para un uso que implique el lavado de vehículos.
- iluminación suficiente (pero lugar no sometido a deslumbramientos o luces intensas). Referencia norma UNI 10380;
- lugar no expuesto a la intemperie;
- lugar en el que está previsto un cambio de aire adecuado;
- ambiente sin contaminantes;
- nivel de ruido inferior a las prescripciones de las normas vigentes I 70 dB (A);
- temperatura del local: mín. 5° - máx. 55°;
- el puesto de trabajo no debe estar expuesto a movimientos peligrosos debidos a otras máquinas en funcionamiento;
- el local donde se instala la máquina no debe estar destinado al almacenamiento de materiales explosivos, corrosivos y/o tóxicos;
- la distancia entre las columnas y las paredes o cualquier equipo fijo debe ser de por lo menos 50 cm;
- escoger el diseño de instalación considerando que desde la posición de mando el operador debe poder ver todo el equipo y el área circundante. Debe impedir, en esta área, la presencia de personas no autorizadas y de todos los objetos que podrían ser fuente de peligro.

Todas las operaciones de instalación relacionadas con las conexiones a alimentaciones externas (eléctricas en particular) deben ser realizadas por personal profesionalmente cualificado.

La instalación debe ser realizada por personal autorizado siguiendo las instrucciones específicas presentes en este manual; en caso de dudas, contactar con los centros de asistencia autorizados o la asistencia técnica de ROTARY

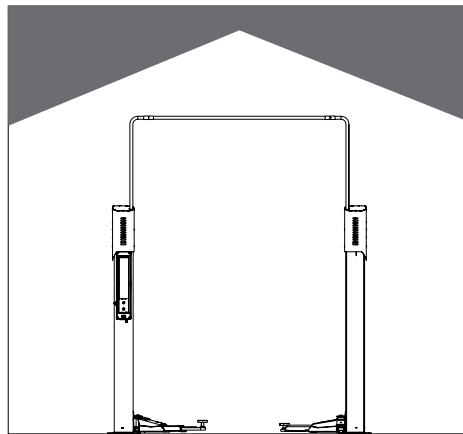

SÍ

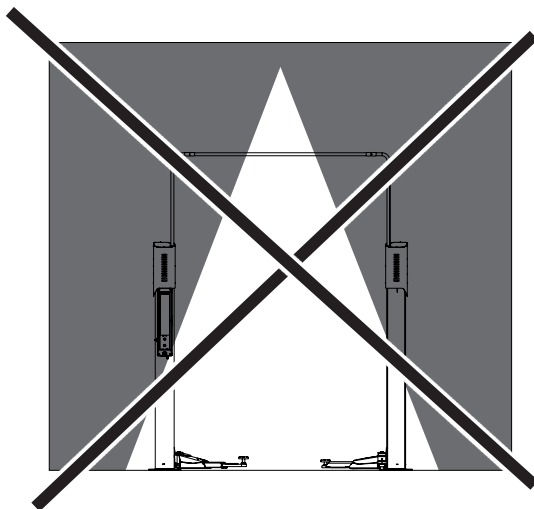

NO

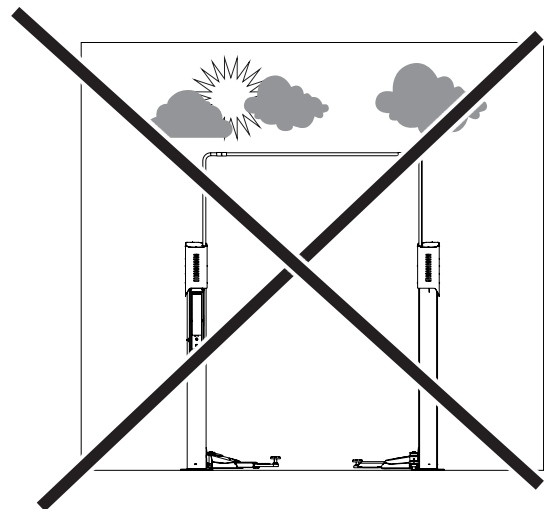

NO

5.2 REQUISITOS DEL SUELO

El elevador debe instalarse sobre una superficie plana y horizontal, capaz de soportar las CARGAS TRANSMITIDAS AL PISO DE APOYO indicadas en la tabla (fig. B). Las características mínimas deben ser:

- a) Calidad del hormigón: mín. C25/30
- b) Espesor mínimo del piso: 160 mm (sin incluir eventuales pavimentos y las respectivas soleras) (*)

Se recomienda consultar con un técnico cualificado para la idoneidad de la instalación

(*) El espesor mínimo depende del tipo de taco utilizado

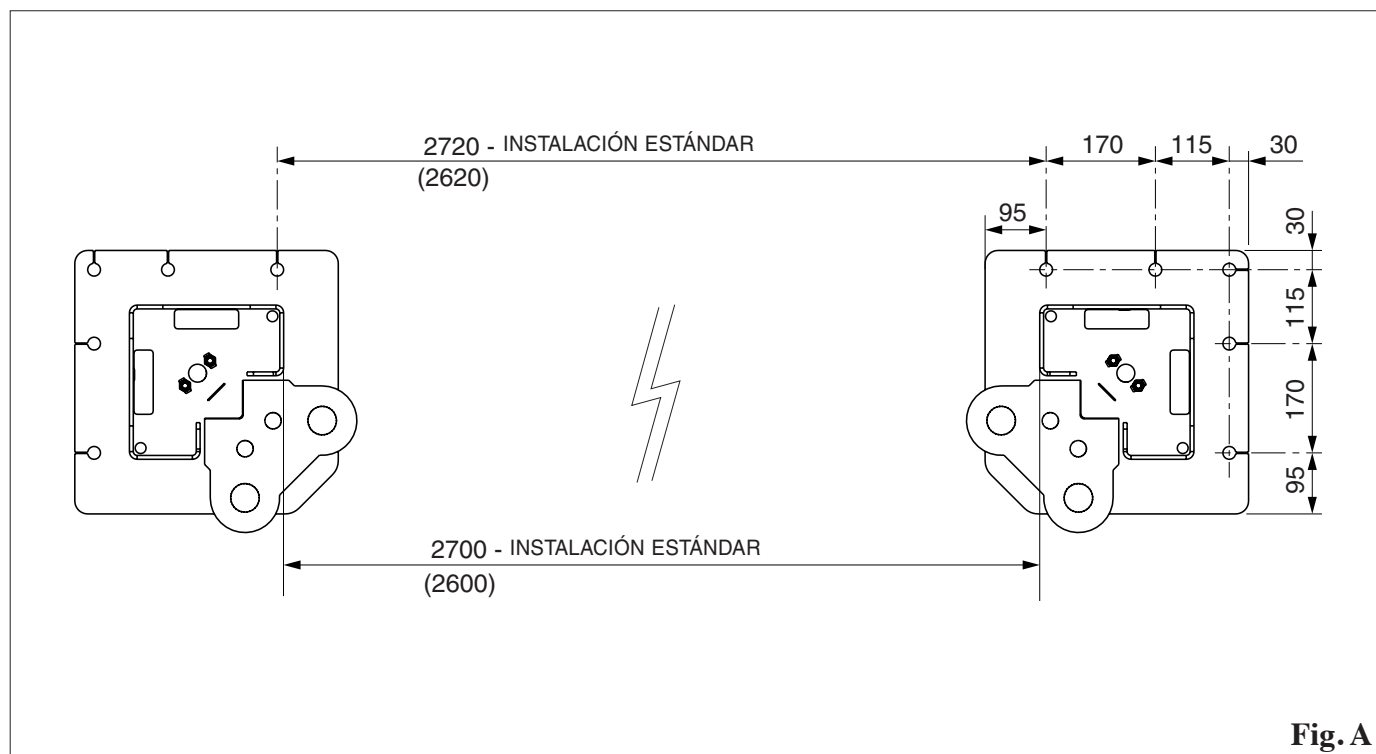
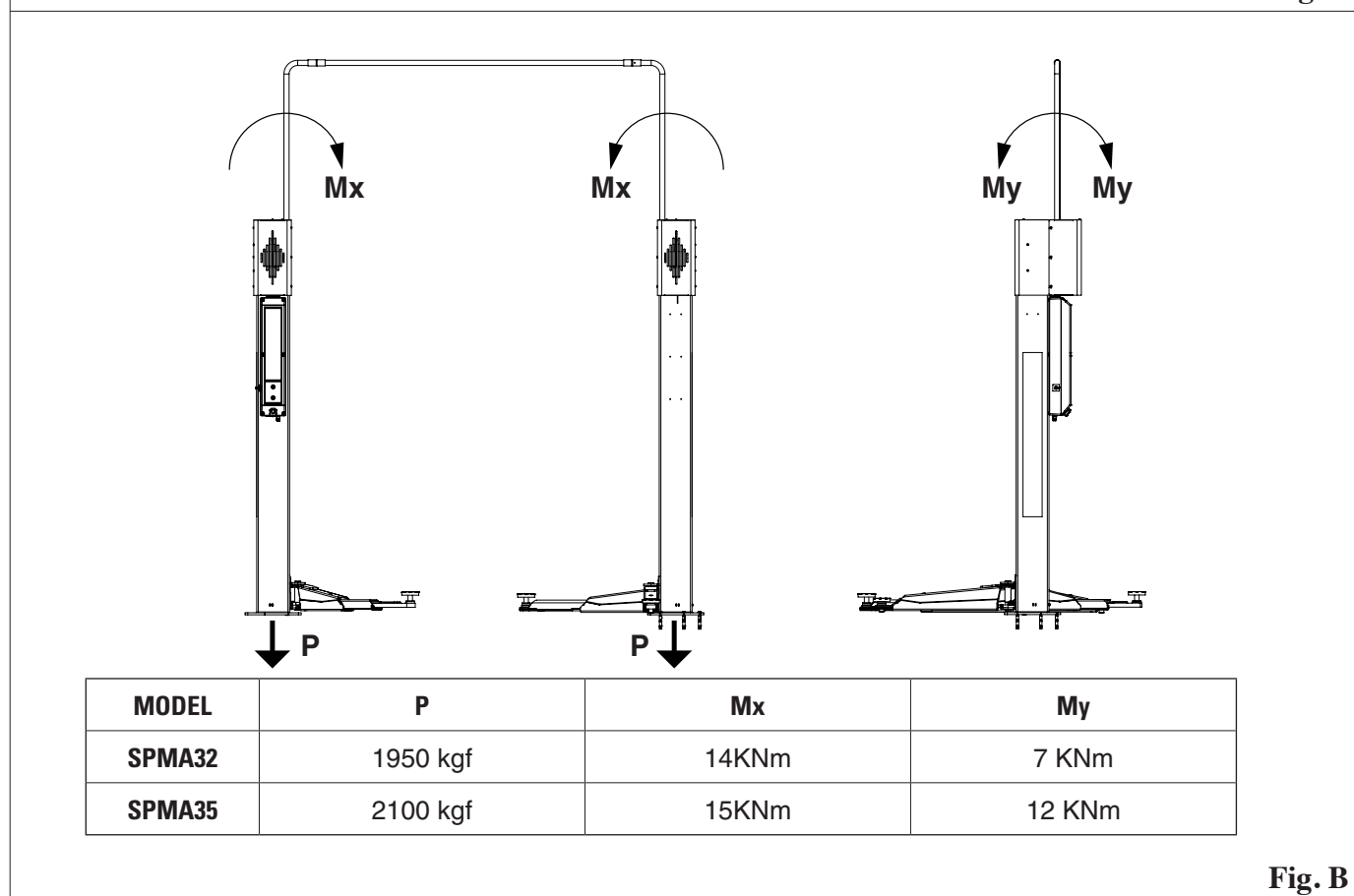
Fig. A

Fig. B

CAP. 6 DESPLAZAMIENTO Y PREINSTALACIÓN

- El elevador se envía como se indica en la figura **A**.
- El paquete (A) contiene los accesorios necesarios para completar el ensamblaje.
- Las maniobras de elevación tienen que realizarse como aparece en la figura **B**.
- Elevar con cuidado y transportar los distintos grupos al sitio donde tendrá lugar el desembalaje.

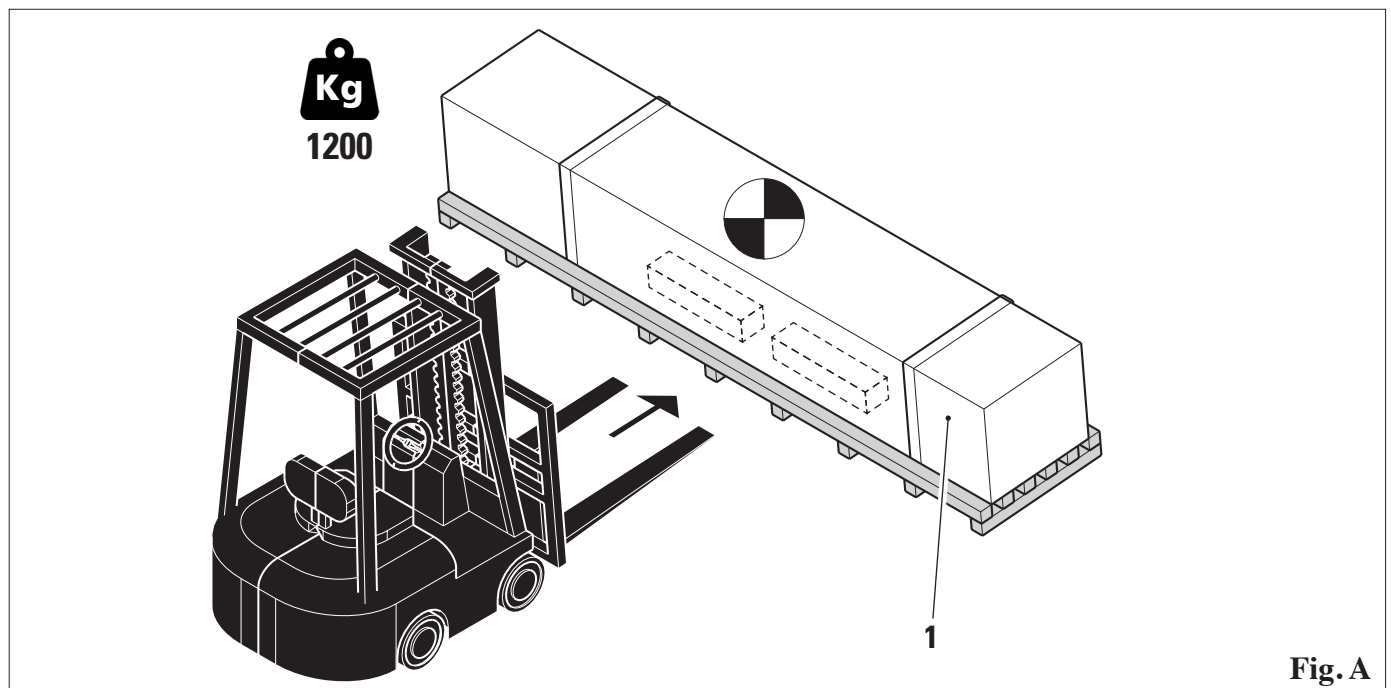
- Para mover la máquina en el punto elegido para su instalación (o para una nueva colocación), hay que asegurarse de:
 - elevar con cuidado, utilizando medios de soporte de la carga adecuados, en perfecto estado, y los correspondientes puntos de enganche como indica la figura **B**;
 - evitar movimientos bruscos y repentinos, prestar atención en los desniveles, cunetas, etc...;
 - prestar la máxima atención en las partes que sobresalen: obstáculos, pasos dificultosos, etc...;
 - llevar prendas y protecciones individuales adecuadas;
 - una vez que se han quitado las distintas partes del embalaje, hay que ponerlo en los correspondientes sitios de recogida, que no estarán al alcance de niños o de animales, para ser eliminados después;
 - asegurarse cuando llega el elevador de que el embalaje esté íntegro y cuando se ha desembalado comprobar que no haya sufrido daños.

Fig. A

Procedimiento de desplazamiento:
 Montar la armella (2) (opcional) en el tornillo (3).
 Posicionar la correa (4) en la armella y en el soporte de la carga como ilustra la figura.
 Levantar con atención la columna hasta llevarla a la posición vertical.
 Quitar la correa de la armella.
 Desmontar la armella (2).

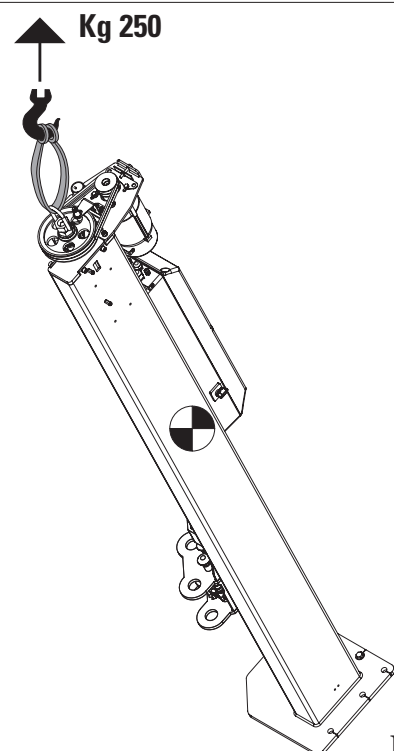
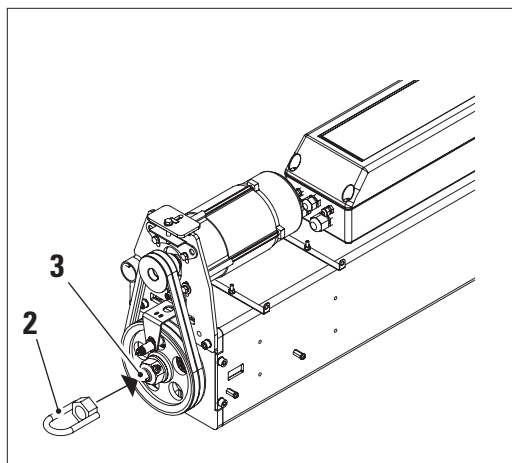
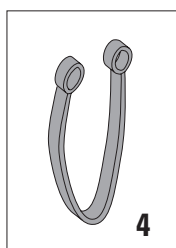
Fig. B

CAP. 7 INSTALACIÓN



7.1 TACOS

Se debe fijar el elevador al suelo por medio de tacos de expansión mecánicos tipo HILTI HSL-3 M12 o similares, o bien anclajes químicos en cápsulas HILTI HVU-M12 o similares (con barra roscada M12 de acero clase 5.8 o superior).

Por lo que atañe a la profundidad del hormigón respecto al plano del suelo, LOS TACOS DEBEN TENER UNA LONGITUD ADECUADA PARA ALCANZAR EL SUELO DE SOPORTE. (ver fig. A-B).

7.2 HORMIGÓN

Para hormigón de clase inferior se aconseja utilizar tacos químicos idóneos.

NOTA: se aconseja apoyar la base de las columnas directamente en el hormigón incluso en presencia de suelo estabilizado. Sin embargo, si este es de buena calidad se pueden fijar las columnas directamente en el suelo, utilizando anclajes de longitud adecuada.

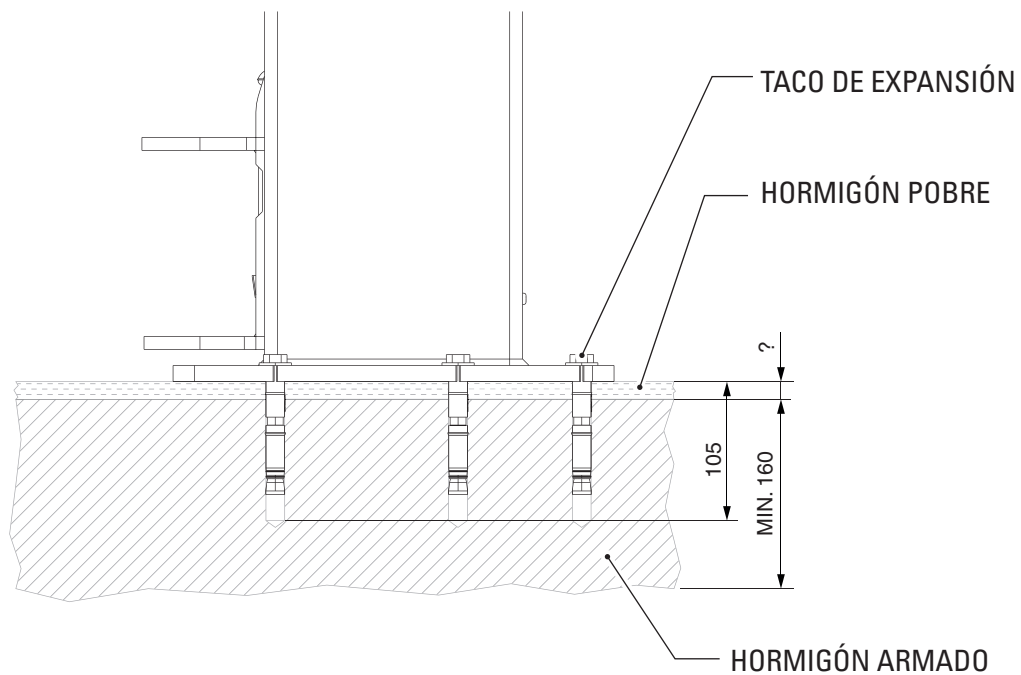

Fig. A

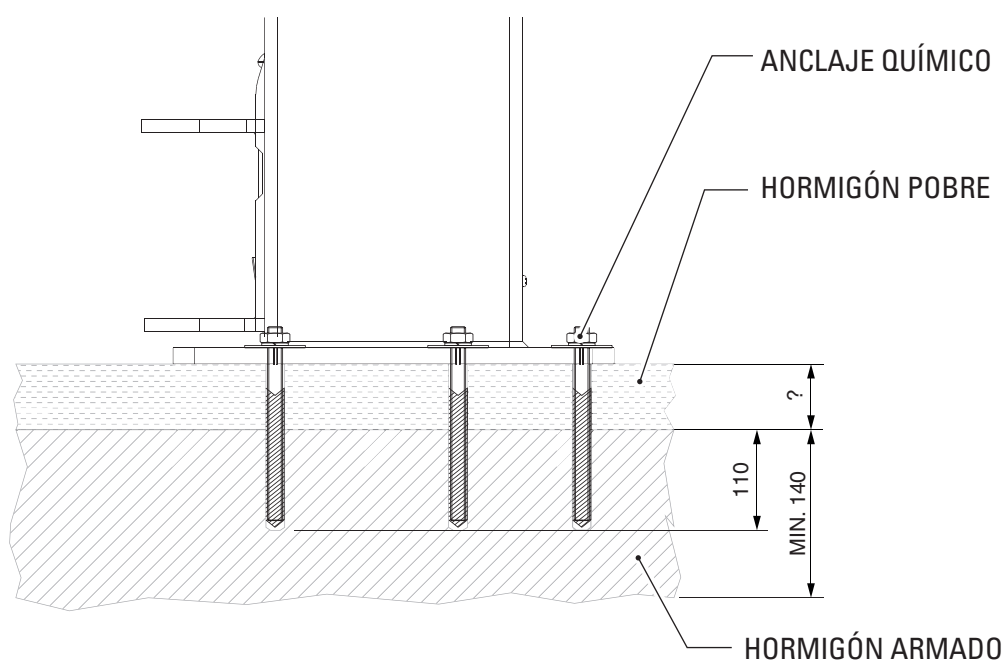

Fig. B

7.3 INSTRUCCIONES PARA LA INSTALACIÓN



La colocación de los tacos debe realizarse utilizando las planchas de base como plantillas de perforación.

N.B.: Para los métodos de colocación y aplicación de los tacos, consultar las especificaciones técnicas suministradas por su fabricante.

Procedimiento de instalación:

- posicionar en vertical una columna;
- Espesorar eventuales luces presentes debajo de la placa de base (fig.B)
- trazar los agujeros y perforar siguiendo los procedimientos indicados por el fabricante de los tacos;
- fijar el taco en posición;
- posicionar en vertical la otra columna, a la distancia indicada en el **cap. 5.2**;
- proceder con las fases de perforación y fijación de tacos descritas anteriormente para ambas columnas.

! Compruebe el anclaje después de una docena de carreras con plena carga, controlando el par de torsión de los tornillos. Este control debe realizarse periódicamente cada tres meses.

- Montar el tubo pasacables (1) en las placas de soporte motor.
- Pasar el cable eléctrico (2) dentro del tubo (1).
- Realizar las conexiones a las cajas de derivación (fig.C).

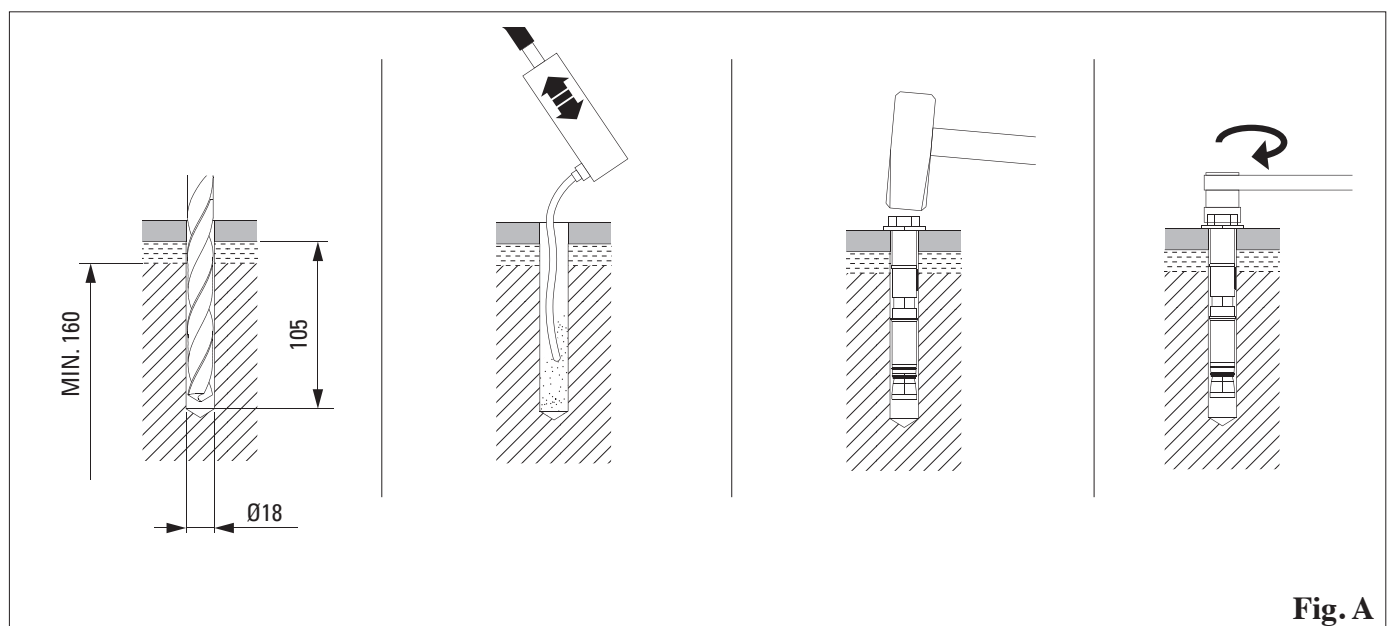

Fig. A

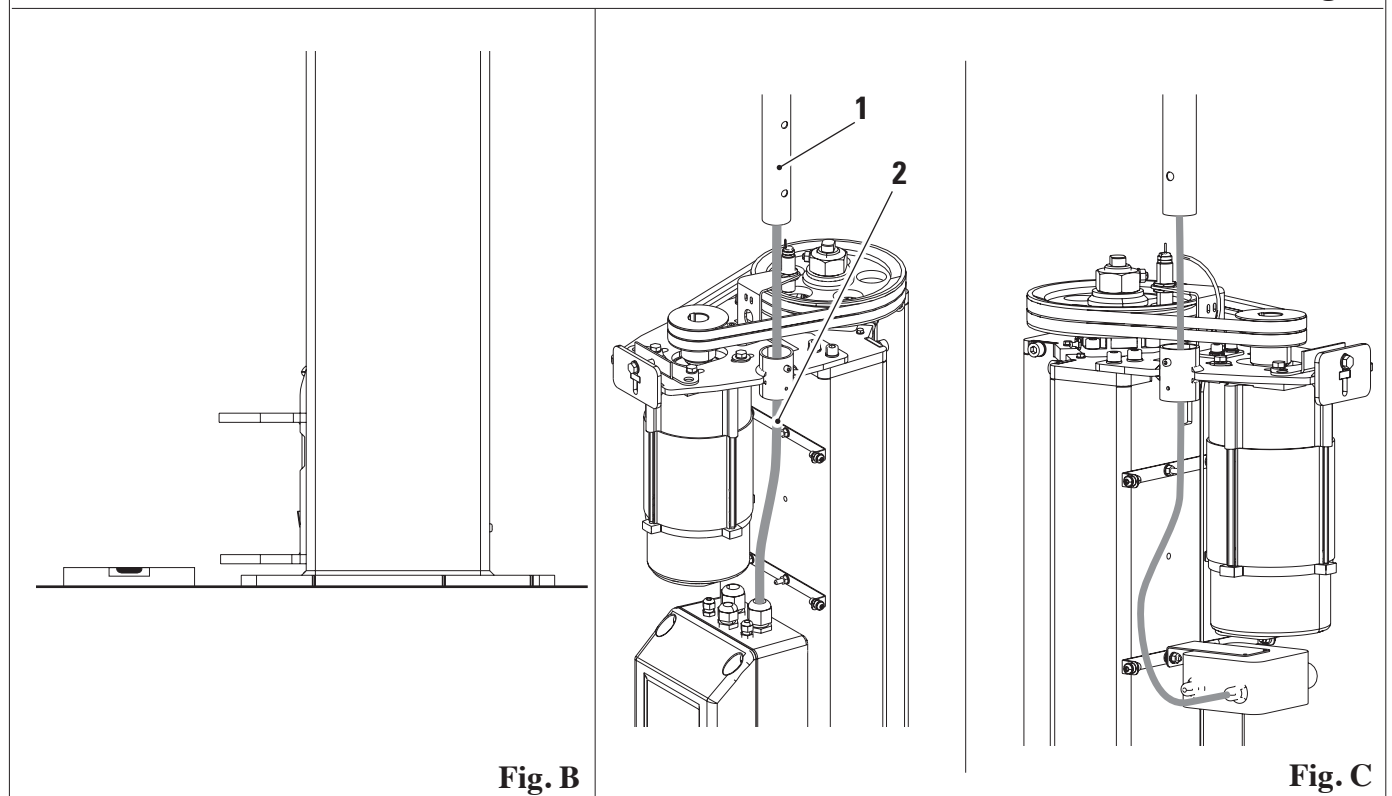

Fig. B

Fig. C

7.4 CONTROL DE TENSIÓN

Controlar que la tensión para la que está preparado el elevador corresponda a la de la red.
De lo contrario es necesario sustituir la instalación eléctrica y efectuar el cambio de tensión en el motor.

7.5 ENLACE A LA RED

Versión trifásica: 400V 50Hz 380V 60Hz
sección cable $\geq 4\text{mm}^2$ 3poli + terra P=11KW I=20A

Versión trifásica: 230V 50Hz 220V 60Hz
sección cable $\geq 6\text{mm}^2$ 3poli + terra P=11KW I=32A

Controlar además que al principio haya un dispositivo de interrupción automática en caso de sobrecorriente, dotado de salvavida de 30mA.

7.6 CONEXIONES

- Pasar el cable de alimentación por el interior del cajón a través del prensacable y conectar los cables al tablero de bornes (véase esquema eléctrico).

Primera instalación.

Atención: El elevador puede encontrarse con los carros sin alinear debido al embalaje.

Colocar los carros a nivel del piso (tope carrera bajada) siguiendo las instrucciones mencionadas en el "Cap. 8.5" del manual.

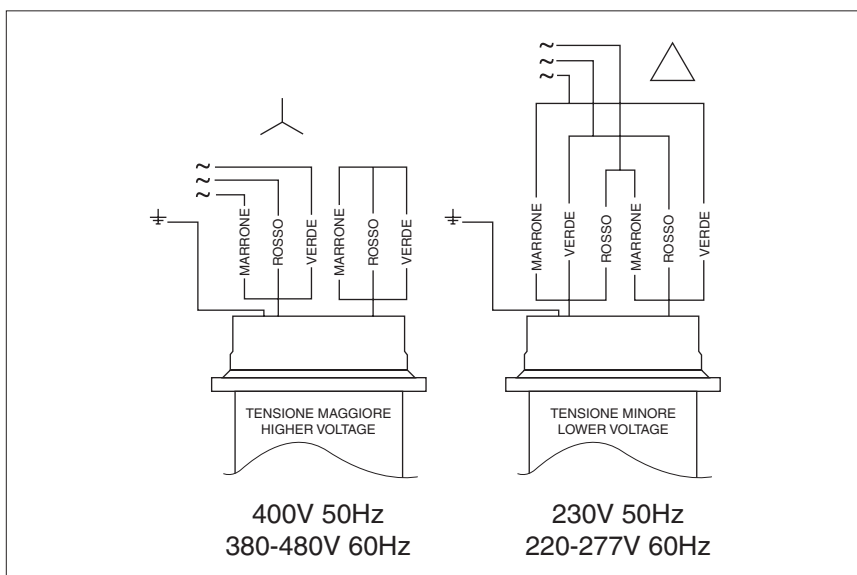
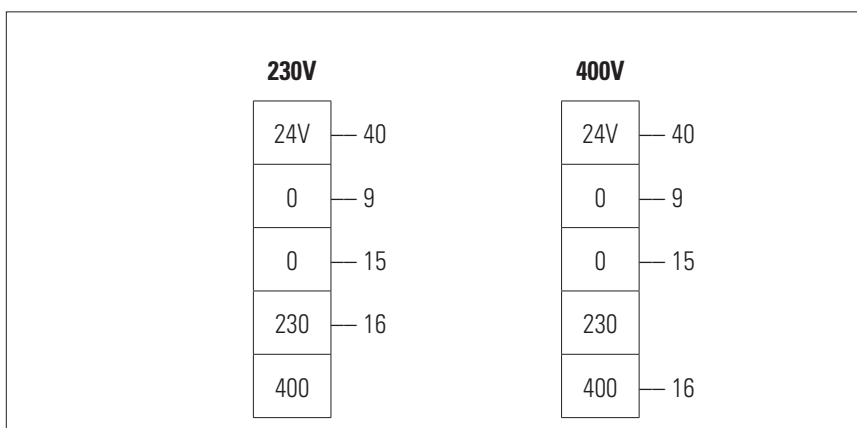

Las intervenciones efectuadas en la instalación eléctrica, incluso de leve envergadura, deben ser efectuadas por personal profesionalmente cualificado.

CONEXIONES DEL MOTOR

CONEXIONES DEL TRANSFORMADOR

FUSIBLES

	230V		400V
	32A		20A

La instalación eléctrica está preajustada para una tensión correspondiente a la indicada en la placa.

7.7 TERMINACIÓN DE LA INSTALACIÓN Y CONTROL



- Accionando el mando de bajada, actuar manualmente en el fin de carrera inferior: la bajada debe detenerse.
- Accionar el mando de subida hasta la elevación completa de los carros controlando que la parada se efectúe por intervención del fin de carrera superior.
- Llenar los tanques de las columnas con aceite ESSO GEAR OIL GX 85W-140 hasta el nivel indicado (ver cap.10).
- Montar la plaqueta sensor polea en ambas columnas Fig. **A**. Controlar que entre el sensor y la polea haya una distancia de 0,5 mm (Fig. **B**).

- Montar los cárteres como ilustra la Fig. **C**:

- montar el cárter (1) fijándolo a los soportes (2);
- montar el cárter (3) fijándolo al cárter (1) y a los soportes (4);
- montar el cárter (5) fijándolo a los cárteres (1) y (3).

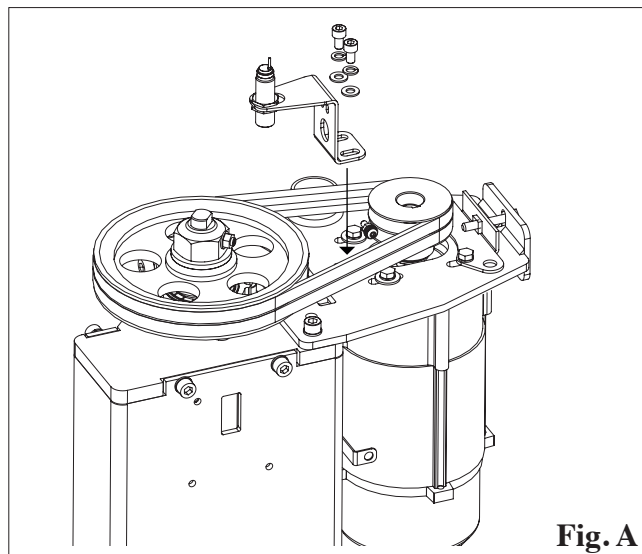
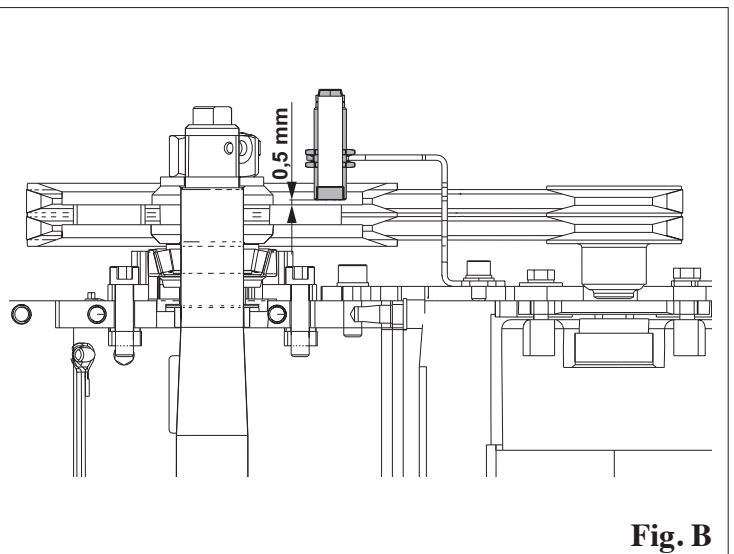
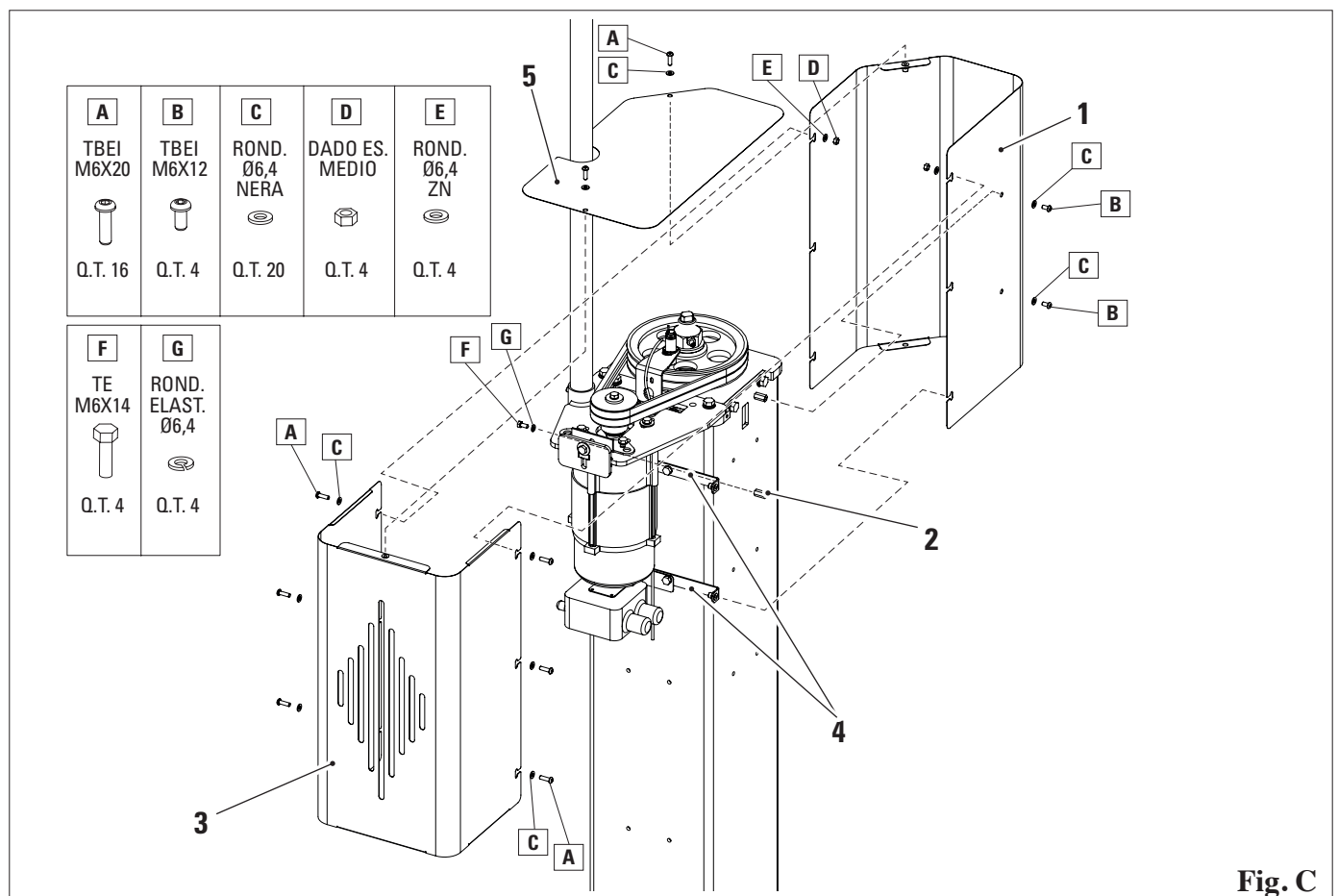

La placa de identificación debe permanecer bien visible tras la instalación.

Fig. A

Fig. B

Fig. C

7.8 MONTAJE BRAZOS



- Llevar los carros a una altura de 70-80 cm.

- Montar los brazos largos y los brazos cortos:

desmontar la rueda dentada (1) desatornillando los tornillos correspondientes; quitar el perno (2); introducir el brazo dentro de las alas del carro y volver a montar el perno (2) y la rueda dentada (1) fijándola con los tornillos.

7.9 USO DE ACCESORIOS

El elevador se puede usar con accesorios para facilitar el trabajo del operador.

  *Se pueden usar solo accesorios originales del fabricante.*

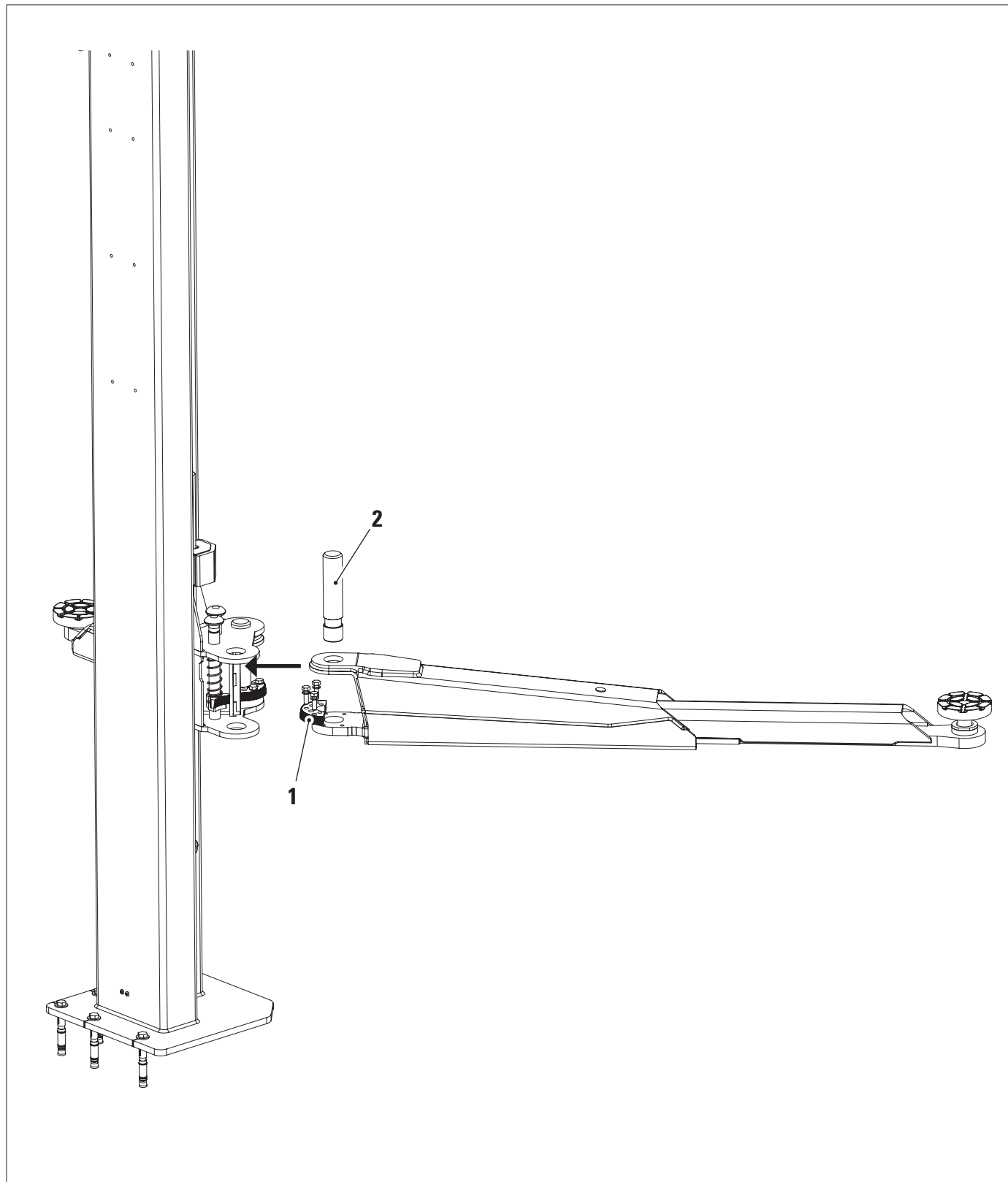

CAP. 8 USO DEL ELEVADOR



8.1 PRECAUCIONES DURANTE EL USO



¡Está terminantemente prohibido permanecer debajo del vehículo durante las operaciones de ascenso y descenso!

- Controlar que durante las maniobras operativas no se creen condiciones de peligro, y parar inmediatamente la máquina en caso de que se encuentren irregularidades en el funcionamiento; ponerse en contacto con el servicio de asistencia del distribuidor autorizado.
- Controlar que en la zona de trabajo alrededor de la máquina no haya objetos potencialmente peligrosos y que no haya aceite, (o cualquier otro material viscoso), esparcido por el suelo ya que es un potencial peligro para el operador.
- El operador tiene que llevar la ropa de trabajo adecuada, gafas de protección, guantes y máscara para evitar el daño que deriva de la proyección de polvo o impurezas; no hay que llevar objetos que cuelguen como pulseras o similares; hay que proteger el pelo largo, y los zapatos tienen que ser adecuados al tipo de operación que hay que efectuar.
- Asegurarse de que el desmontaje de una parte del vehículo no altere la distribución de la carga más allá de los límites aceptables previstos.
- Colocar en cero el interruptor general cuando se efectúen operaciones en el vehículo levantado.

8.2 DESPLAZAMIENTO Y COMPORTAMIENTO DURANTE LAS FUNCIONES DEL ELEVADOR

Cumplir los procedimientos descritos a continuación:

- Identificar el peso del vehículo.
 - Identificar la distribución de la carga.
 - Asegurarse de centrar el vehículo respecto al puente con la máxima precisión posible.
 - Identificar los puntos de toma del vehículo y seguir las instrucciones del fabricante.
- **Procedimiento de posicionamiento correcto de los apoyos:** agarrar el brazo telescópico con las manos para extraerlo (ver figura); dirigir y posicionar el apoyo en los puntos de toma del vehículo anteriormente identificados. No usar pies u otros sistemas diferentes de los mencionados.
- Elevar el carro a una altura de poco más de 30 cm y con pequeños empujes en el vehículo comprobar la correcta estabilidad de los puntos de toma y el acoplamiento de los topes.
 - Durante el movimiento de ascenso y descenso, controlar el punto de apoyo en el vehículo.

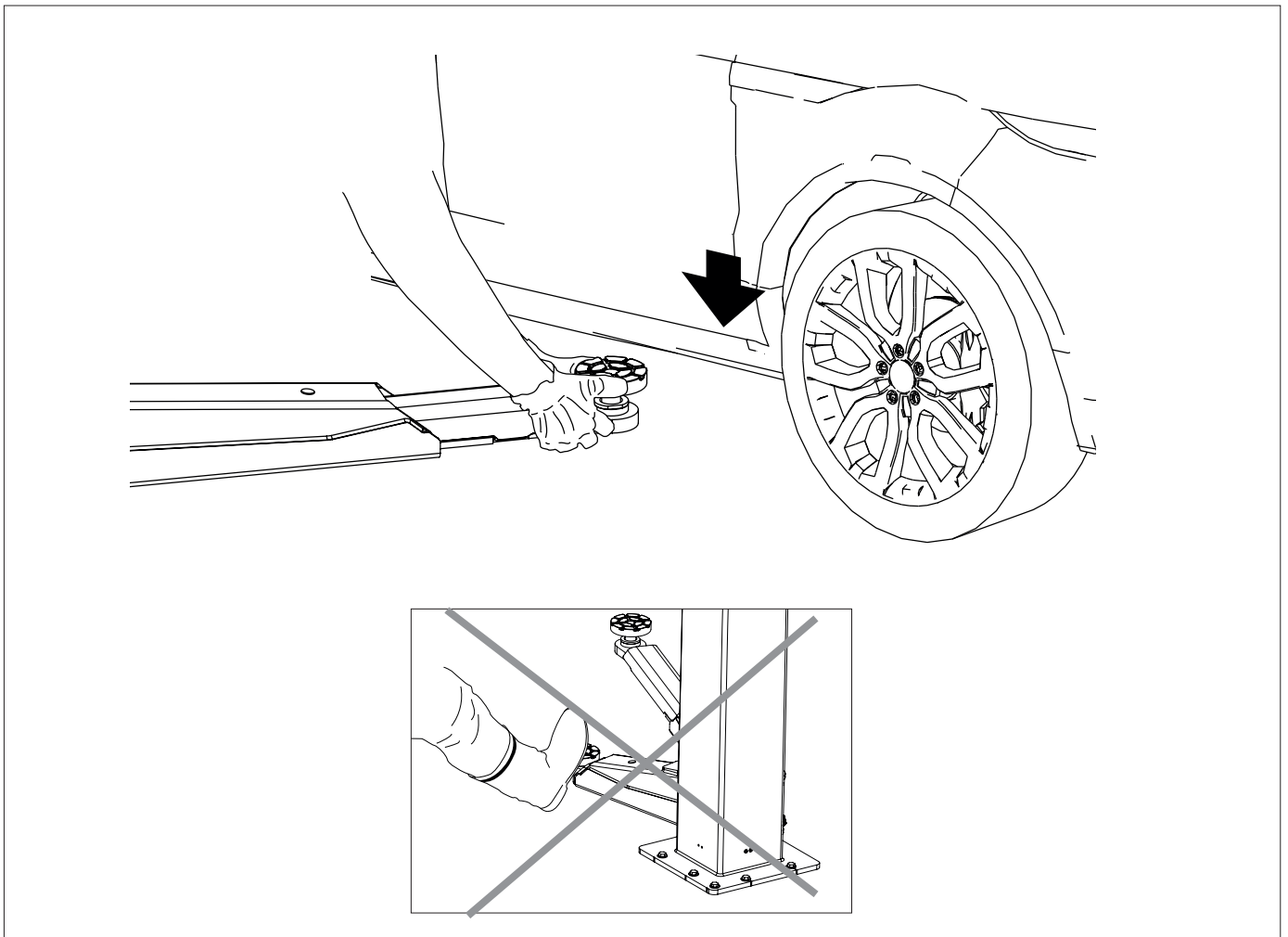

8.3 IDENTIFICACIÓN DE LOS MANDOS Y SUS FUNCIONES

 Cajas de mandos cód. **047303060 - 047303070 / 047303080**

Identificación mandos: INTERRUPTOR (1), PULSADOR (2), PULSADOR (3) AVISADOR ACÚSTICO (4), PULSADOR DE EMERGENCIA (5)

Función:

	<ul style="list-style-type: none"> • Circuito eléctrico desactivado • Posición con bloqueo con candado 		Presionado: movimiento de ascenso
	Circuito eléctrico activado		Presionado: movimiento de descenso
	<ul style="list-style-type: none"> • Pulsadores (2) y (3) desactivados • TEqLINK activado • Posición con bloqueo con candado 		Presionado: desactiva el circuito eléctrico
	<ul style="list-style-type: none"> • Pulsadores (2) y (3) desactivados • TEqLINK activado • Posición con bloqueo con candado 		Activo: elevador en bloqueo y carros a una altura peligrosa con mando de descenso accionado

047303060

Caja de mandos con interruptor y pulsadores ascenso y descenso.

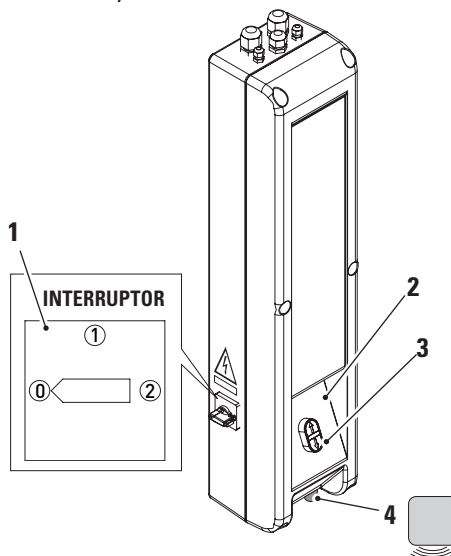
047303070 / 047303080

Doble caja de mandos con interruptor, pulsadores ascenso y descenso, pulsador de emergencia.

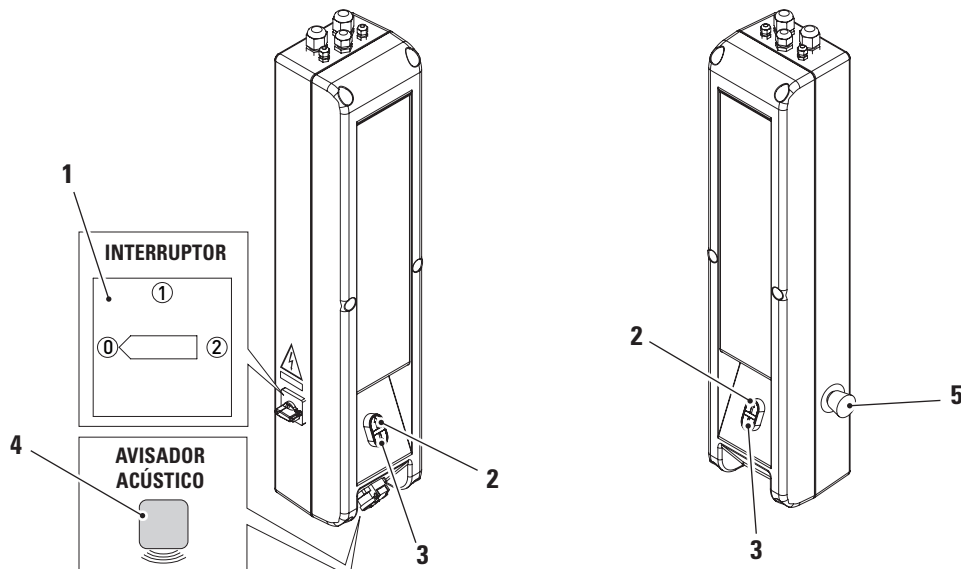

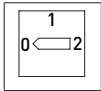
PROCEDIMIENTO DE EMERGENCIA: DESCENSO EN AUSENCIA DE TENSIÓN

Girar el interruptor a la posición 0 (quitar la posibilidad de un retorno de la alimentación eléctrica).

- **DESCENSO DE EMERGENCIA:** En caso de falta de corriente, se puede volver a colocar la carga en el suelo quitando los cárteres de la parte superior de las columnas y haciendo girar los tornillos de maniobra con una llave de 17 mm, alternando columna de mando y columna opuesta para no superar los 50 mm de diferencia entre las cotas de los carros.

Una vez reactivado el circuito eléctrico, hay que poner a cero los contactores haciendo subir el puente unos 5 cm y luego bajándolo.



¡ATENCIÓN! La operación debe ser llevada a cabo por personal cualificado, prestando atención a la posición de la carga para evitar desequilibrios en las dos plataformas que pueden perjudicar la estabilidad de la carga.

8.4 USO IMPROPIO DEL ELEVADOR

El elevador está diseñado para la elevación de vehículos con las características previstas en el cap. 2 y cap. 3. Cualquier otro uso se considera impropio e irracional; en concreto está absolutamente prohibido:

- 1) elevar personas y animales
- 2) elevar vehículos con personas a bordo
- 3) elevar vehículos que lleven material potencialmente peligroso (explosivos, corrosivos, inflamables, etc...)
- 4) La elevación de los vehículos **NO** colocados en los puntos de apoyo.
- 5) La elevación de los vehículos con accesorios no previstos por la Empresa ROTARY
- 6) que use el elevador el personal que no esté adecuadamente formado y autorizado.
- 7) Uso como gato.
- 8) Uso de un solo par de brazos en sentido longitudinal o trasversal.
- 9) Uso de un único brazo.
- 10) Uso de los brazos para comprimir y aplastar.

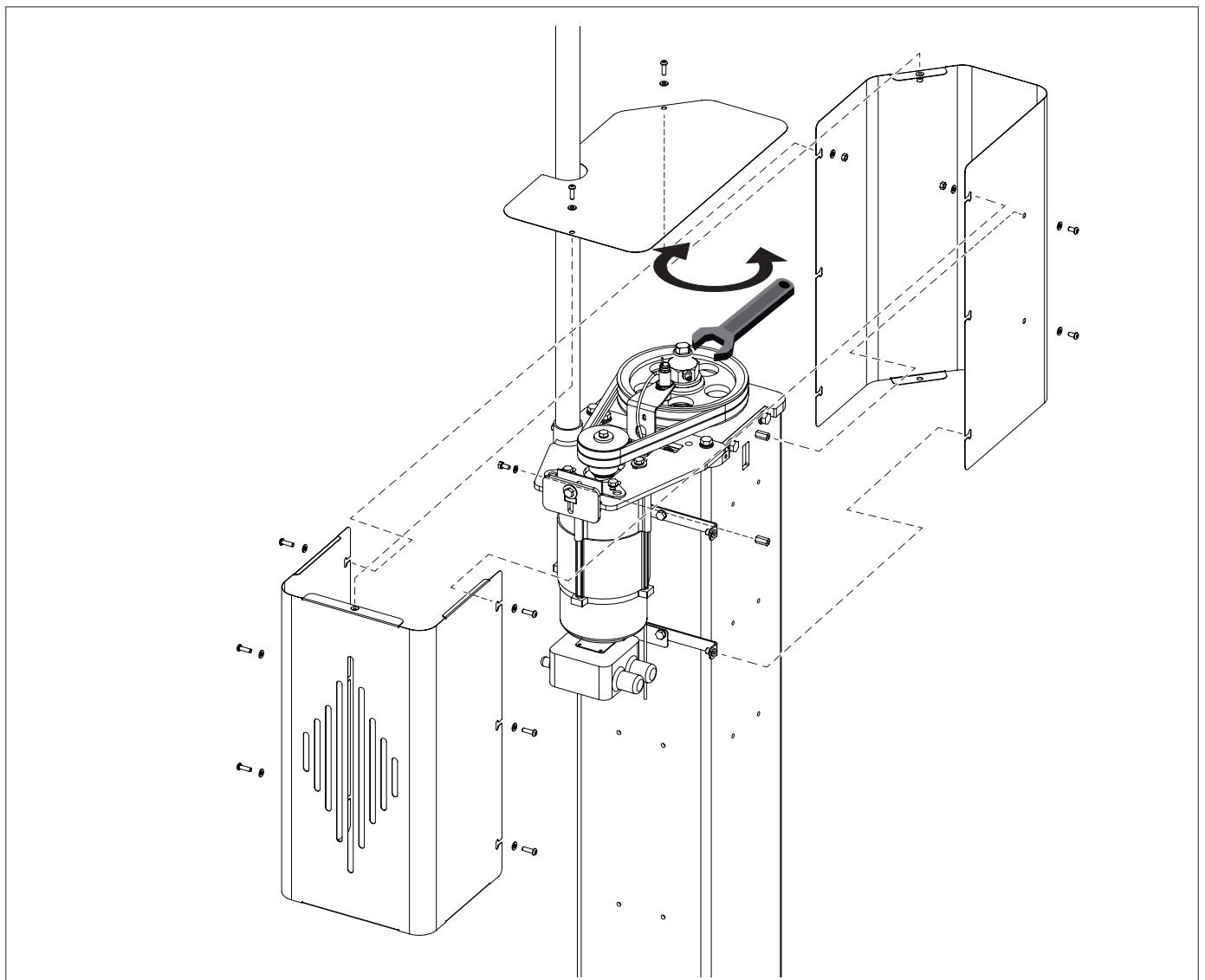

8.5 FUNCIONES DEL DISPOSITIVO DE CONTROL SINCRONIZACIÓN.



⚠️ ¡Atención! Para las verificaciones y los procedimientos de emergencia, es necesaria la intervención de un técnico especializado ya que se trabaja en presencia de tensión eléctrica.

Dentro del cuadro se encuentra la tarjeta electrónica (1), que dispone de un LED (2) que permanece encendido cuando el interruptor está en las siguientes condiciones:

Interruptor caja de mandos cód. **047303060 - 047303070**

	Circuito eléctrico activado
	<ul style="list-style-type: none"> • Pulsadores (4) y (5) desactivados • TEqLINK activado • Posición con bloqueo con candado

Inconveniente: puente bloqueado (advertencia avisador acústico).

Solución: es posible el descenso de emergencia (descenso individual).

- Si el puente se encuentra en condición de bloqueo es posible hacer descender los carros.

- Girar a

- Quitar la tapa de la caja eléctrica.
- Desplazar hacia abajo la leva (3) en manual (A).

- Girar a

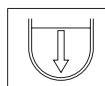

Descenso individual de los carros. Accionar el mando de descenso y contemporáneamente presionar:

- pulsador **P1** para mover el carro de la columna de mando; pulsador **P2** para mover el carro de la columna opuesta.

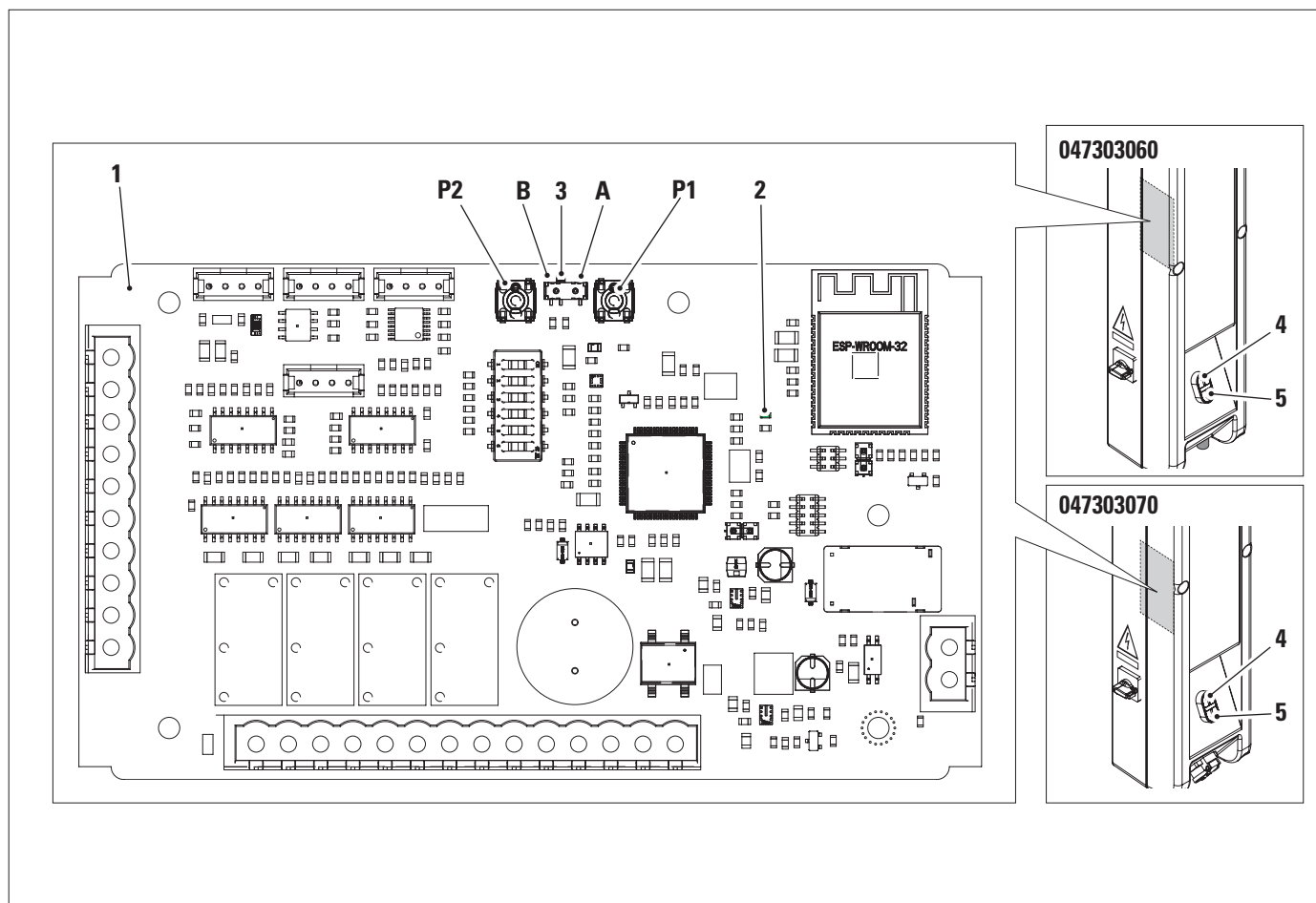



Atención: durante el descenso manual el sistema de sincronización carros no está activo. Maniobras que se deben efectuar correctamente y con mucha atención para evitar la desalineación peligrosa del vehículo.



- Hacer descender ambos carros, el último que llega al final de carrera descenso reinicia el bloqueo (avisador acústico apagado con mando de descenso accionado).

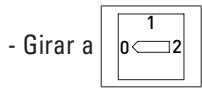

- En la tarjeta, posicionar la leva (3) en (B) (en automático).
- Montar la tapa de la caja eléctrica.

N.B.: en modalidad manual se permite solo el descenso.

Si la maniobra no es factible, significa que la tarjeta está bloqueada por seguridad porque ha detectado una condición peligrosa.

Para reiniciar el bloqueo de seguridad seguir las indicaciones a continuación:



- en la tarjeta, posicionar la leva (3) en (A) (en manual);

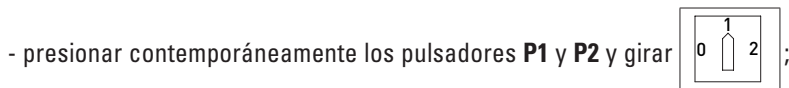

- mantener presionados los pulsadores P1 y P2 durante 5 segundos;
- el LED (1), ya encendido, parpadeará una vez;
- posicionar la leva en (3) en (B) (en automático).

Atención:

- si el bloqueo ha sido generado por una avería hardware (tarjeta o sistema eléctrico), el bloqueo se volverá a presentar inmediatamente;
- si la avería está en la tarjeta, se deberá sustituir;
- si la avería está en el sistema, se deberá solucionar.

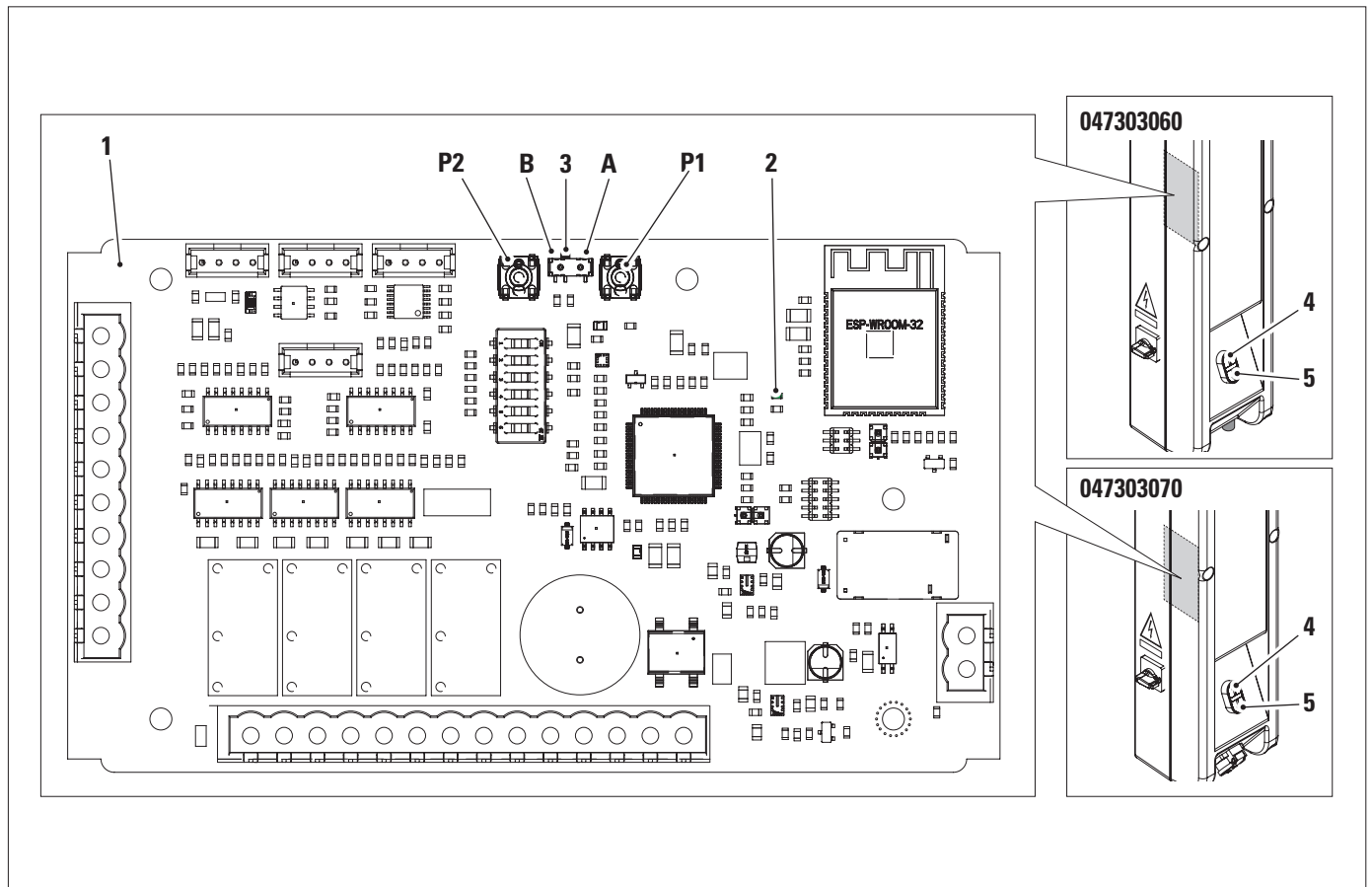

CAP. 9 DISPOSITIVOS DE SEGURIDAD

Interruptor general bajo candado



Interruptor caja de mandos cód. 047303060 - 047303070	
	<ul style="list-style-type: none"> • Circuito eléctrico desactivado • Posición con bloqueo con candado
	<ul style="list-style-type: none"> • Pulsadores desactivados • TEqLINK activado • Posición con bloqueo con candado

Sistema “hombre muerto”

El elevador tiene un sistema de tipo “hombre muerto”, las operaciones de subida o descenso son interrumpidas de inmediato al soltar el interruptor-invertidor de mando.

Topes mecánicos

El puente está dotado de topes mecánicos que funcionan en caso de anomalías del final de carrera, al final de la carrera de ascenso o de descenso.

En estas situaciones, mandar en intervalos la maniobra opuesta a la operación anterior para una carrera de 5-10 cm.

Controlar el final de carrera interesado, y sustituirlo si fuera necesario.

Además de los topes mecánicos mencionados, se puede verificar la desconexión de la sonda térmica del motor; el rearme automático de esta última ocurrirá después de unos 3 minutos.

Reajuste de los carros



Cualquier uso indebido o modificación de la máquina que no hayan sido autorizadas por el fabricante lo eximen de los posibles daños que puedan derivar o estar relacionados con los actos mencionados.

Quitar o usar indebidamente los dispositivos de seguridad comporta una violación de las Normas Europeas de Seguridad.

Cada vez que se produce una diferencia en altura de los carros igual a 18 mm, el dispositivo de control se activa automáticamente, con el fin de reestablecer la nivelación correcta.

Bloqueo de emergencia

Este tipo de bloqueo se activa en caso de:

- desalineación de los carros superior a 40 mm;
- bloqueo de los motores;
- ruptura del cablecito de alineación.

Maniobras permitidas en condiciones de emergencia

- Cuando el elevador se encuentra en condiciones de emergencia (ver párrafo anterior) ninguna maniobra de subida o bajada está permitida por medio de los pulsadores. Para reestablecer el funcionamiento del elevador, consultar con el Servicio Post-Venta.
- Si fuera necesario remover el vehículo del elevador, se pueden bajar los carros activando manualmente las poleas.

Bloqueo desgaste tuercas portantes

Insistiendo en el uso del elevador más allá del límite indicado en el Cap. 10.2, se produce el desgaste total y la parada mecánica de la tuerca.

La activación del dispositivo ocurre cuando los carros llegan a su final de carrera de descenso.

Se señala con el avisador acústico, activo en modo: **1s ON** y **1s OFF**.

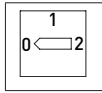
CAP. 10 MANTENIMIENTO

Colocar el interruptor general en 0 (cero) cuando se efectúan las operaciones de mantenimiento.



*Atención: órganos mecánicos en movimiento.
Quien remueve las protecciones lo hace bajo su propia responsabilidad.*

10.1 ACTIVIDAD DE MANTENIMIENTO

Efectuar controles periódicos en los dispositivos de seguridad cada 3 meses



Es necesaria una evaluación de la vida útil restante tras 10 años de actividad del elevador, realizada por un técnico cualificado, preferiblemente autorizado por el fabricante.

• MENSUAL

Tuercas portantes - Desmontar las cortinas de protección con los carros a 50 cm del suelo, controlar las tuercas utilizando la plaqueta (1) suministrada: se debe introducir en la garganta como en la figura, si no se logra posicionar el lado STOP, sustituir la tuerca.

• TRIMENSUAL

Guías de deslizamiento - Lubricar las guías de deslizamiento de los patines aplicando grasa (fig. B).

Cojinetes - Quitar los cárteres de cobertura motor e inyectar grasa en los engrasadores (2).

• ANUAL

Cubetas de lubricación - Desmontar las cortinas de protección y llenar la cubeta (3) de lubricación con aceite (ESSO GEAR OIL 85W-140 o equivalente).

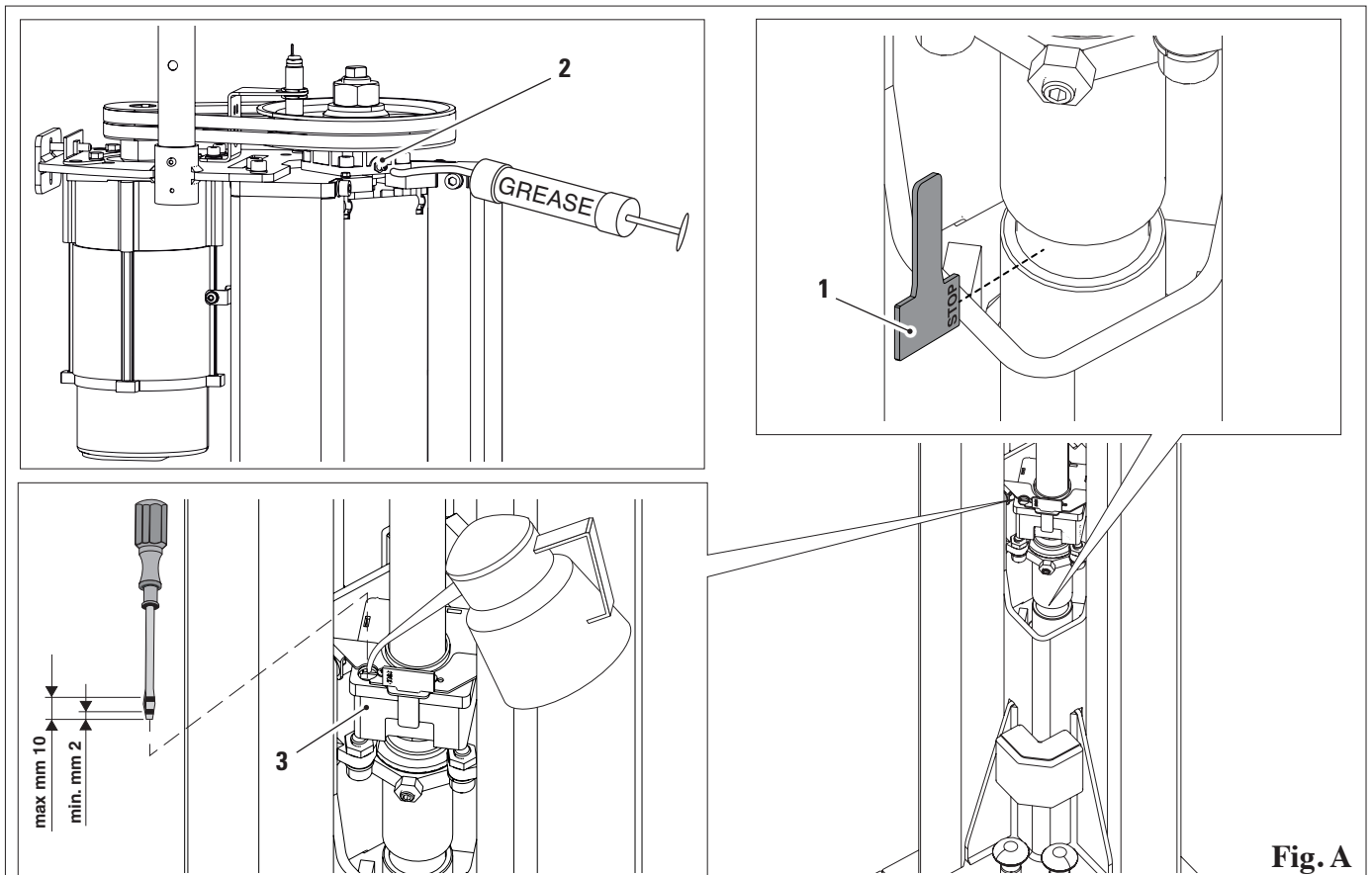
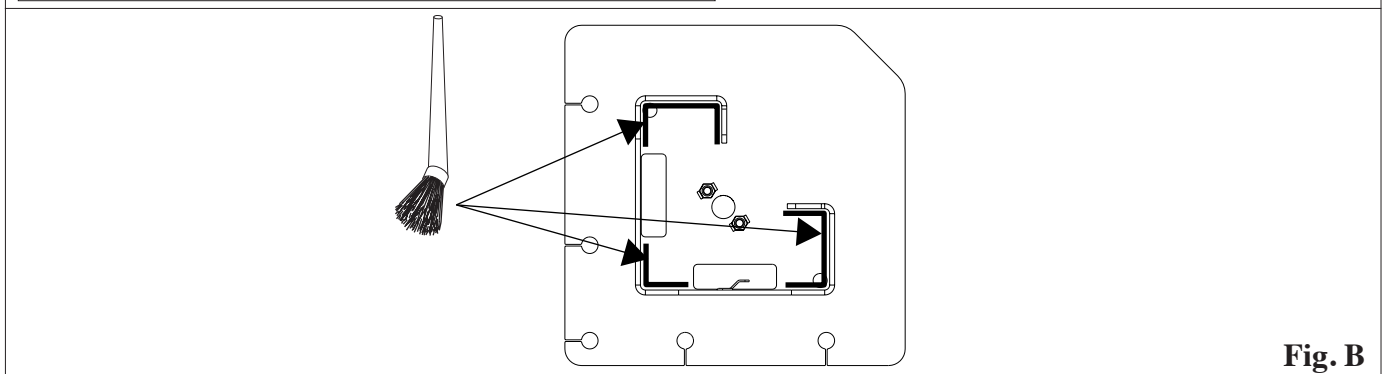
Fig. A

Fig. B

Plan de mantenimiento programado

Intervalo de TIEMPO	Tipo de MANTENIMIENTO	Plan de MANTENIMIENTO	POSICIÓN*	CRITICIDAD
DÍA	ETIQUETAS	Controlar y, si es necesario, sustituir las etiquetas de seguridad dañadas o ilegibles	En columna En cuadro	MEDIA
	BRAZOS	Comprobar estado del protector pies, desgaste o daños, sustituir si es necesario	Brazos	MEDIA
	BRAZOS	Comprobar el estado de los apoyos, desgaste o daños, sustituir si es necesario	Brazos	BAJA
MES	COJINETE	Engrasar cojinete portante del tornillo (ver indicación actual)	Sobre el tornillo	ALTA
	TUERCA	Comprobar estado del tornillo, desgaste o daños, sustituir si es necesario (ver indicación actual)	Sobre el carro	ALTA
	TUERCA	Comprobar el nivel de aceite en la cubeta de lubricación, si es necesario llenarla (ver indicación actual)	Sobre el carro	ALTA
	TUERCA DE SEGURIDAD	Engrasar la contratuerca de seguridad con grasa multiuso, NO usar grasa de base sólida (Molicote), como grafito.	Sobre el carro	MEDIA
TRIMESTRE	GUÍAS DESLIZAMIENTO	Lubricar con grasa (sin suspensiones sólidas) las guías de deslizamiento de los patines de los carros		ALTA
	TACOS	Comprobar el anclaje tras diez carreras a plena carga, controlando el par de apriete de los tacos.	En columna	ALTA
AÑO	CORREA	Comprobar la tensión correcta de la correa y su desgaste, si es necesario tensar o sustituir	Sobre la columna	ALTA
	TORNILLO	Comprobar el estado del tornillo, desgaste o daños, sustituir si es necesario	Dentro de la columna	ALTA
	COMPONENTES ELECTRÓNICOS	Comprobar el estado de los componentes eléctricos y electrónicos, conexiones intactas y daños en cajas de bornes o conectores	Cuadro eléctrico	ALTA
	PINTURA	Controlar daños y abrasiones en las superficies pintadas si es necesario, lijar y pintar para evitar daños de óxido	Columna Carro	MEDIA
	SOLDADURAS	Controlar daños y agrietamientos en las soldaduras presentes en columna, carro y brazos. Si es necesario, intervenir limpiando la zona y restableciendo la soldadura	Columna Carro	ALTA
	TORNILLOS DE FIJACIÓN	Controlar el apriete de todos los tornillos de fijación Si es necesario, intervenir apretando con llave dinamométrica		
	BRAZOS	1. Limpiar y lubricar los pernos 2. Controlar los muelles de los pernos, reparar y sustituir si es necesario 3. Controlar los daños presentes en los brazos y en los topes de las prolongaciones 4. Controlar el sistema de parada brazos, roscas y desgaste, sustituir si es necesario	Brazos	MEDIA
	PATINES	Controlar daños y desgaste de los patines y de las guías de deslizamiento. Si es necesario sustituir y aplicar espesores en los patines, limpiando la zona y lubricando	Carro	MEDIA

10.2 DESGASTE TUERCA Y SUSTITUCIÓN GRUPO TORNILLO



El desgaste de la tuerca portante causa su rotura; en este caso, el carro bajará unos 20 mm.

Esta condición es detectada por la tarjeta electrónica cuando se activan los finales de carrera de descenso, señalados por el avisador acústico que se activa en modo 1 seg. ON - 1 seg. OFF.

Por lo tanto, la maniobra de ascenso no se puede realizar.

La rotura de la espiral requiere la sustitución de todo el grupo tornillo.

Procedimiento sustitución grupo tornillo:

- Llevar el carro a una altura de aprox. 350 mm e introducir un bloque de madera (1) debajo de él.
- Quitar tensión a la máquina.
- Desmontar la cortina (2).
- Desmontar los cárteres (3).
- Desmontar el soporte proximity (4) (atención: no el proximity de su soporte).
- Desmontar las correas de transmisión (5).
- Girar la polea hasta llevar el carro en contacto con el bloque de madera (fig. C).
- Desmontar antirrotación cubeta (6).
- Desmontar tornillo prisionero y tuerca (7).
- Desmontar tornillos de sujeción (8).
- Desmontar tornillos de soporte cojinete (9).
- Girar la tuerca hasta llevar que la tuerca de seguridad llegue a tope (sentido horario) (10).
- Atornillar la armella en la extremidad del tornillo (11).
- Extraer con movimiento diagonal el grupo tornillo del puente (fig. D).
- Volver a realizar las operaciones en orden inverso para el montaje del recambio (prestando especial atención a la fijación del tornillo prisionero).
- Realizar la PUESTA A CERO, ver capítulo 8.5.

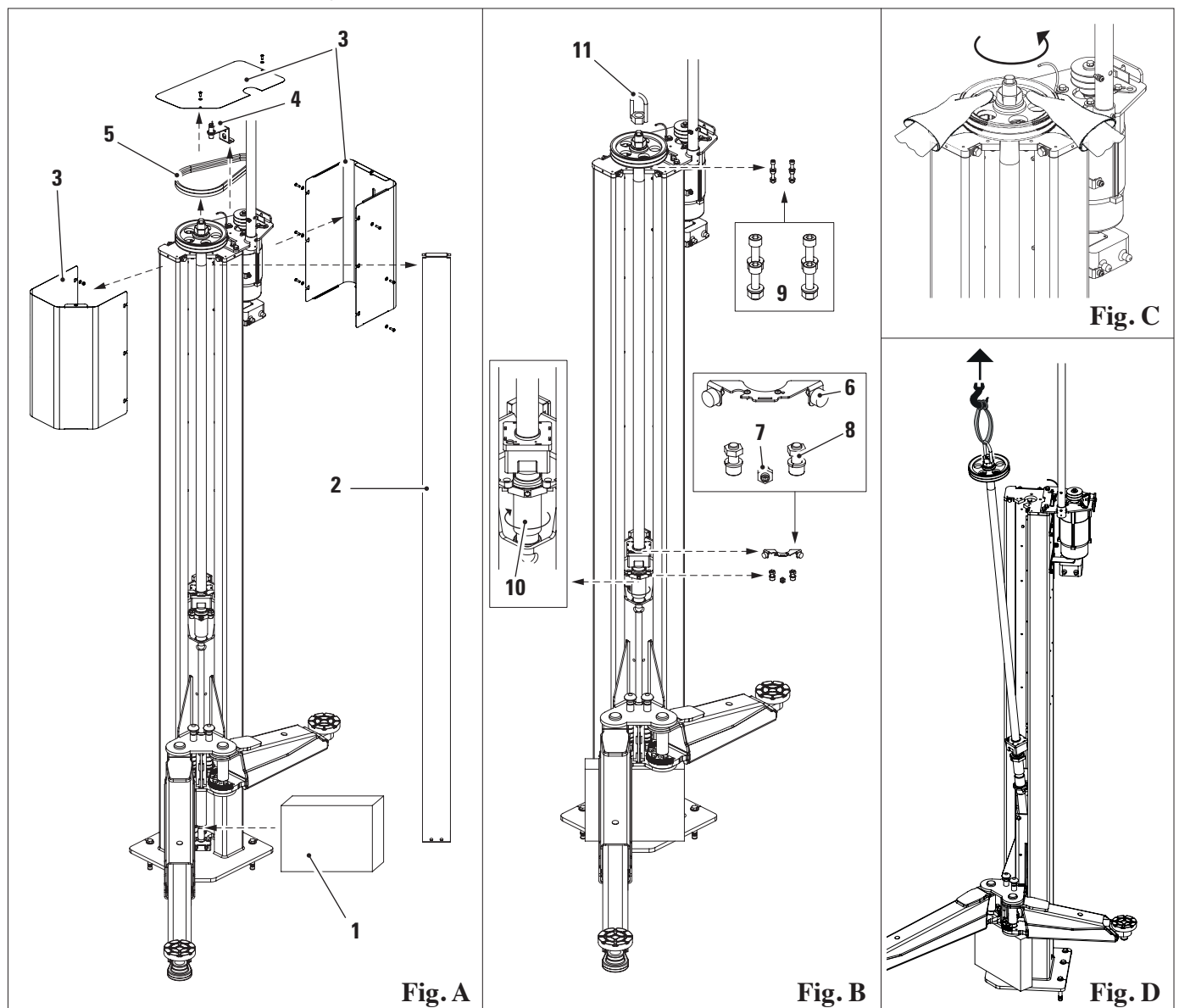

10.3 TROUBLE SHOOTING

A continuación tenemos una lista de los posibles inconvenientes que pueden surgir durante el funcionamiento del puente elevador. ROTARY declina toda responsabilidad por los daños causados a personas, animales o cosas, debidos a la intervención de personas no autorizadas. Por consiguiente se recomienda ponerse en contacto lo antes posible con la asistencia técnica de manera que se puedan tener las indicaciones necesarias para poder realizar las operaciones y/o regulaciones en condiciones de máxima seguridad, evitando de esta manera el riesgo de causar daños a personas, animales o cosas.



Es necesario que intervenga la asistencia técnica. Está prohibido intervenir personalmente.



INCONVENIENTES	CAUSAS	SOLUCIÓN
No funciona. Avisador acústico apagado.	Tensión de alimentación.	Controlar la tensión en los cables de alimentación. Controlar interruptor / inversor del elevador. Controlar los fusibles de línea. Controlar transformador mandos y fusibles correspondientes.
No completa la carrera. Avisador acústico apagado.	Desactivación sonda térmica motor.	Esperar el rearme.
No funciona. Avisador acústico encendido.	Elevador en bloqueo de emergencia. Interruptor de proximidad. Motor parado.	Ver capítulo 8.5 Ajustar / sustituir. Controlar correas motor.
No funciona. Avisador acústico encendido: 2 seg. ON / 2 seg. OFF	Interruptor tarjeta en manual tras poner a cero el bloqueo.	Poner interruptor en automático.
No levanta los carros en el final de carrera de descenso. Avisador acústico encendido: 1 seg. ON / 1 seg. OFF	Bloqueo por desgaste tuercas.	Ver capítulo 10.2.
No funciona, ni siquiera en manual. Avisador acústico encendido.	Bloqueo de seguridad.	Ver capítulo 8.5

CAP. 11 ELIMINACIÓN-DESGUACE

11.1 DESMONTAJE

El trabajo de desmontaje puede ser realizado solo por personal cualificado y autorizado. Solo electricistas cualificados pueden trabajar en el sistema eléctrico.

1. Para realizar el trabajo de desmontaje, apagar el equipo con el interruptor principal (posición OFF).
2. Desconectar la alimentación eléctrica.
3. Vaciar el tanque del aceite. Desechar el aceite hidráulico y los líquidos de funcionamiento, como descrito en el capítulo 11.3.
4. Quitar la grasa y otras sustancias químicas. Eliminar como descrito en el capítulo 11.3
5. Las operaciones de desmontaje se realizan en orden contrario a las fases de montaje (ver cap. 7).

11.2 DESUSO

- En el caso de que no se utilice durante un largo periodo hay que desconectar las fuentes de alimentación, vaciar el/los depósito/s que contienen los líquidos de funcionamiento y proteger las partes que se podrían dañar si se depositase el polvo.
- Engrasar las partes que se podrían dañar si se secasen.
- Si se vuelve a poner en funcionamiento sustituir las juntas indicadas en la parte piezas de repuesto.

11.3 ELIMINACIÓN

Procedimientos medioambientales para la eliminación

Prevenir riesgos medioambientales.

Evitar el contacto o la inhalación de sustancias tóxicas como fluido hidráulico.

Aceites y lubricantes son contaminantes del agua según establece la ley sobre la gestión de las aguas WGH. Eliminarlos siempre de forma ecológica, cumpliendo con las normas vigentes en el país de instalación.

El aceite hidráulico a base de aceite mineral es contaminante del agua y es combustible. Consultar la ficha de datos de seguridad sobre la eliminación.

Asegurarse de que ningún aceite hidráulico, lubricante o material para la limpieza contamine el suelo o se elimine en la red de alcantarillado.

Embalaje

¡No eliminar con residuos domésticos! El embalaje contiene algunos materiales reciclables, que no se deben eliminar con los residuos domésticos.

1. Eliminar los materiales de embalaje en conformidad con las normas locales.

Aceite, grasa y otras sustancias químicas.

1. Cuando se trabaja con aceites, grasas y otras sustancias químicas, respetar las normas medioambientales que se aplican al producto en cuestión.
2. Eliminar el aceite, las grasas y otras sustancias químicas de acuerdo con las normas medioambientales que se aplican en el país de instalación.

Metales / Residuos electrónicos

Deben siempre ser eliminados correctamente por una empresa certificada.

RELACIÓN DE INSTALACIÓN

OPERACIÓN DE CONTROL PARA SER RELLENADO POR EL INSTALADOR

Elevador modelo _____

Matrícula _____

Comprobación de la capacidad del pavimento	<input type="checkbox"/>
Comprobación de la tensión de alimentación	<input type="checkbox"/>
Interruptor general	<input type="checkbox"/>
Mando subida y bajada	<input type="checkbox"/>
Movimiento correcto del carro – mando de accionamiento	<input type="checkbox"/>
Control del funcionamiento tope de carrera de bajada	<input type="checkbox"/>
Control par de apriete de los tacos	<input type="checkbox"/>
Control del correcto deslizamiento de los brazos telescópicos	<input type="checkbox"/>
Control de la correcta introducción y desganche de la detención de los brazos	<input type="checkbox"/>
Control del nivel del dispositivo de lubricación del tornillo	<input type="checkbox"/>
Control de la lubricación de las guías de deslizamiento	<input type="checkbox"/>
Control de la presencia y colocación de los adhesivos	<input type="checkbox"/>
Capacidad	<input type="checkbox"/>
Advertencias	<input type="checkbox"/>
Matrícula	<input type="checkbox"/>

Firma y sello del instalador

Data de instalación

CONTROL PERIÓDICO

Operación de control	fecha	firma	fecha	firma	fecha	firma	fecha	firma	fecha	firma
	Comprobación del estado de desgaste del tornillo patrón	<input type="checkbox"/>		<input type="checkbox"/>		<input type="checkbox"/>		<input type="checkbox"/>		<input type="checkbox"/>
Interruptor general	<input type="checkbox"/>		<input type="checkbox"/>		<input type="checkbox"/>		<input type="checkbox"/>		<input type="checkbox"/>	
Mando subida y bajada	<input type="checkbox"/>		<input type="checkbox"/>		<input type="checkbox"/>		<input type="checkbox"/>		<input type="checkbox"/>	
Control del funcionamiento tope de carrera de bajada	<input type="checkbox"/>		<input type="checkbox"/>		<input type="checkbox"/>		<input type="checkbox"/>		<input type="checkbox"/>	
Control par de apriete de los tacos	<input type="checkbox"/>		<input type="checkbox"/>		<input type="checkbox"/>		<input type="checkbox"/>		<input type="checkbox"/>	
Control del correcto deslizamiento de los brazos telescópicos	<input type="checkbox"/>		<input type="checkbox"/>		<input type="checkbox"/>		<input type="checkbox"/>		<input type="checkbox"/>	
Control de la correcta introducción y desganche de la detención de los brazos	<input type="checkbox"/>		<input type="checkbox"/>		<input type="checkbox"/>		<input type="checkbox"/>		<input type="checkbox"/>	
Control del nivel del dispositivo de lubricación del tornillo	<input type="checkbox"/>		<input type="checkbox"/>		<input type="checkbox"/>		<input type="checkbox"/>		<input type="checkbox"/>	
Control de la lubricación de las guías de deslizamiento	<input type="checkbox"/>		<input type="checkbox"/>		<input type="checkbox"/>		<input type="checkbox"/>		<input type="checkbox"/>	
Control de la presencia y colocación de los adhesivos	<input type="checkbox"/>		<input type="checkbox"/>		<input type="checkbox"/>		<input type="checkbox"/>		<input type="checkbox"/>	
Control integridad de los tapones de elevación	<input type="checkbox"/>		<input type="checkbox"/>		<input type="checkbox"/>		<input type="checkbox"/>		<input type="checkbox"/>	
Capacidad	<input type="checkbox"/>		<input type="checkbox"/>		<input type="checkbox"/>		<input type="checkbox"/>		<input type="checkbox"/>	
Advertencias	<input type="checkbox"/>		<input type="checkbox"/>		<input type="checkbox"/>		<input type="checkbox"/>		<input type="checkbox"/>	
Matrícula	<input type="checkbox"/>		<input type="checkbox"/>		<input type="checkbox"/>		<input type="checkbox"/>		<input type="checkbox"/>	



Installer:

Please return this booklet to literature package, and give to lift owner/operator.

Thank You

Trained Operators and Regular Maintenance Ensures Satisfactory Performance of Your Rotary Lift.

Contact Your Nearest Authorized Rotary Parts Distributor for Genuine Rotary Replacement Parts. See Literature Package for Parts Breakdown.

Revision	Date	Change(s) Made
----------	------	----------------

World Headquarters:
Rotary Lift
A  **DOVER** COMPANY
2700 Lanier Drive
Madison, Indiana USA
Phone: 1.800.445.5438
Phone: 1.812.273.1622
Fax: 1.800.578.5438
Fax: 1.812.273.6502
userlink@rotarylif.com
www.rotarylif.com

Germany:
(European Headquarters)
BlitzRotary GmbH
Bräunlingen
Phone: +49.0771.9233.0
Fax: +49.0771.9233.99
europe@rotarylif.com

Canada:
(Regional Sales Office)
Rotary Lift Canada
Mississauga, Ontario
Phone: 888.256.4195
Phone: 905.812.9920
Fax: 905.812.9719
canada@rotarylif.com

United Kingdom:
(Regional Sales Office)
Rotary Lift (UK) LTD.
Halstead, Essex
Phone: +44.178.747.7711
Fax: +44.178.747.7720
sales@rotarylif.idps.co.uk

Austral-Asia:
(Regional Sales Office)
Rotary Lift Austral/Asia
Petaling Jaya, Malaysia
Phone: +60.3.7660.0285
Fax: +60.3.7660.0289
rlim@rotarylif.com

