

Bodenverschraubung/Bottom screwing

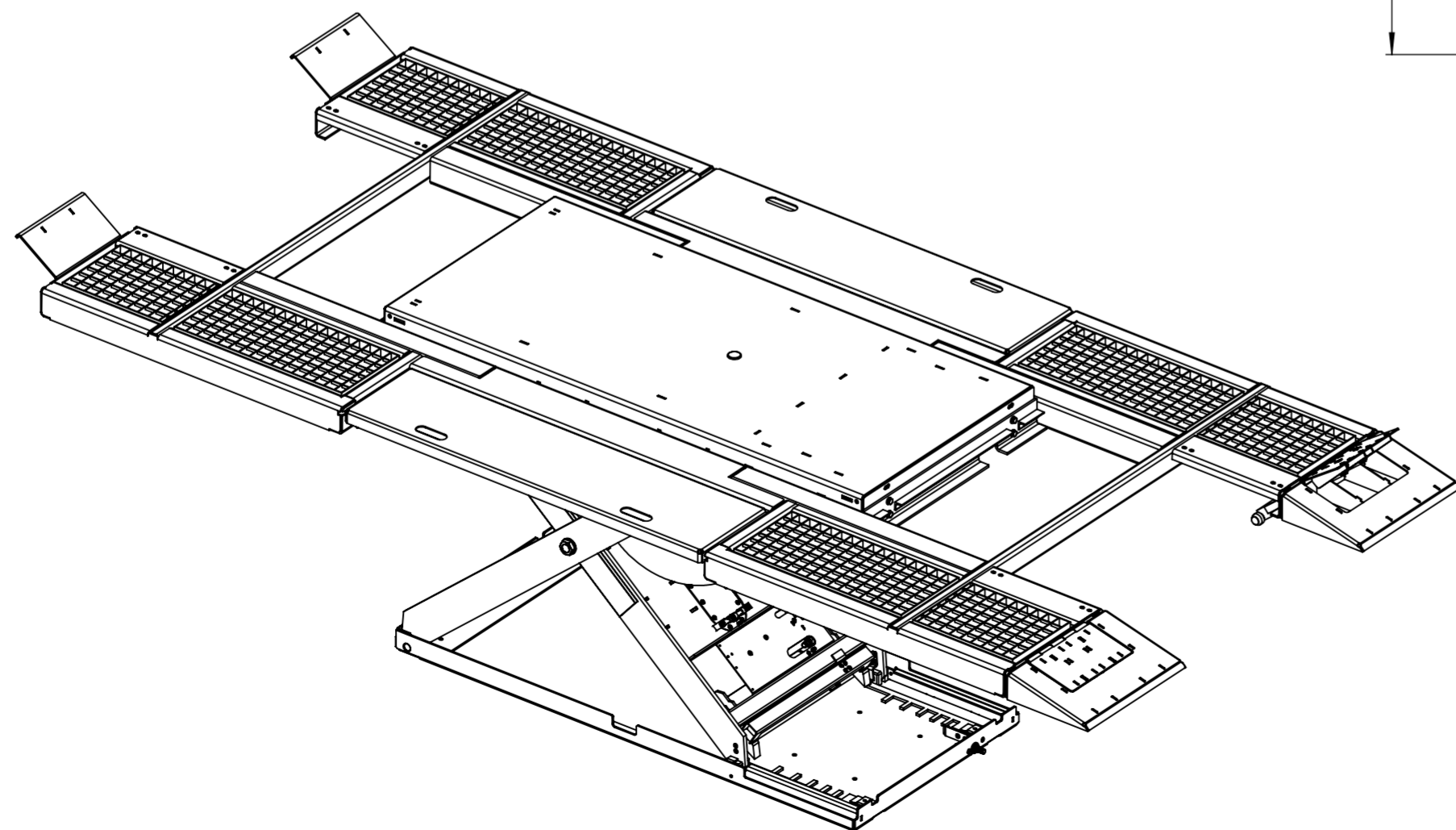

Zubehör/Accessories

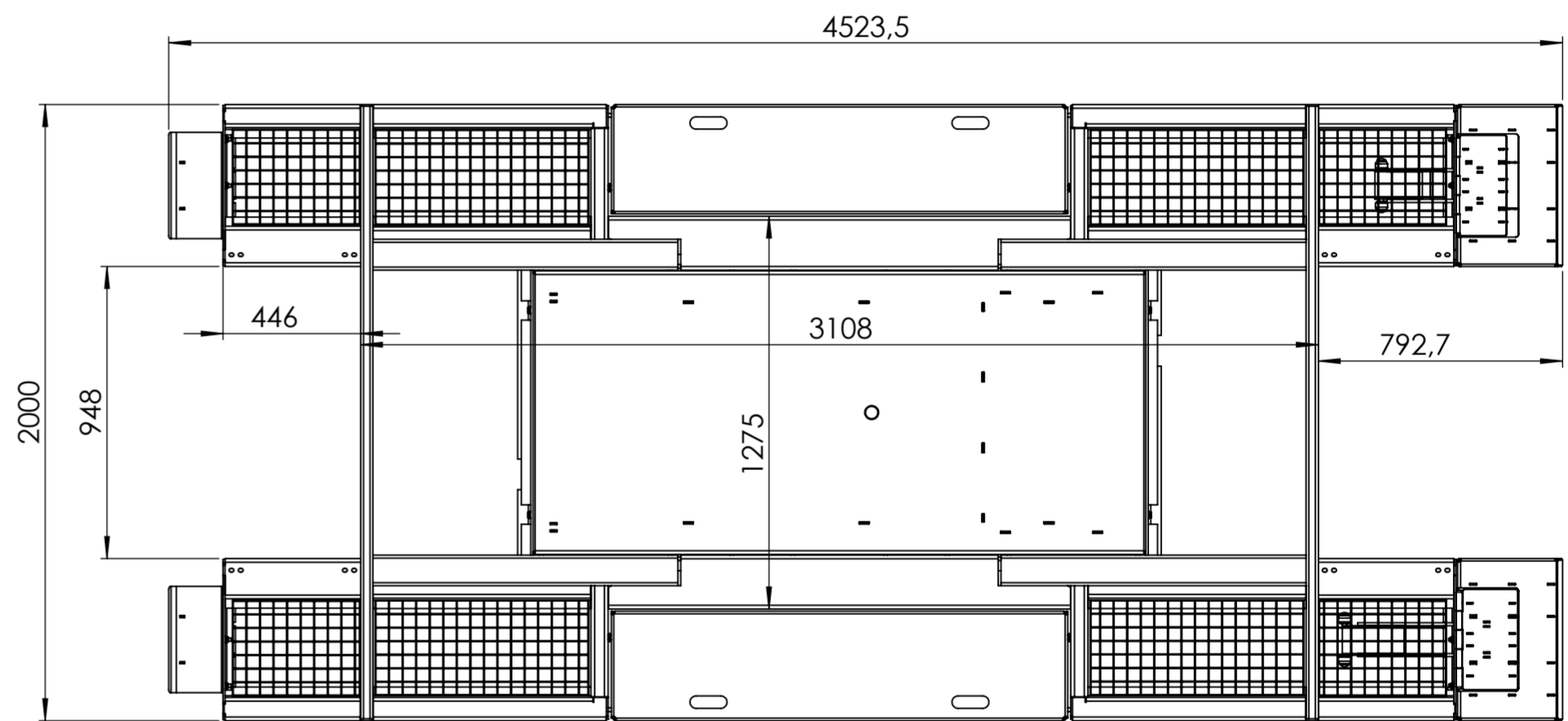
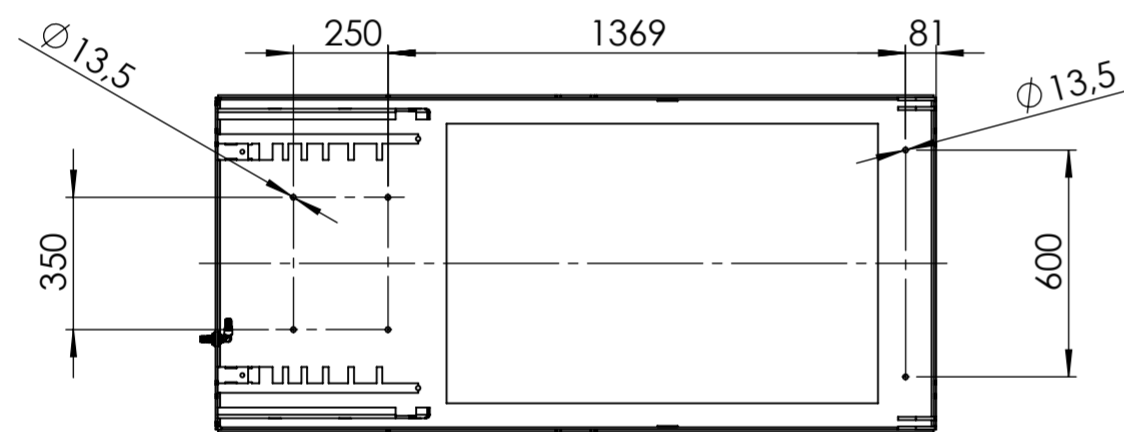
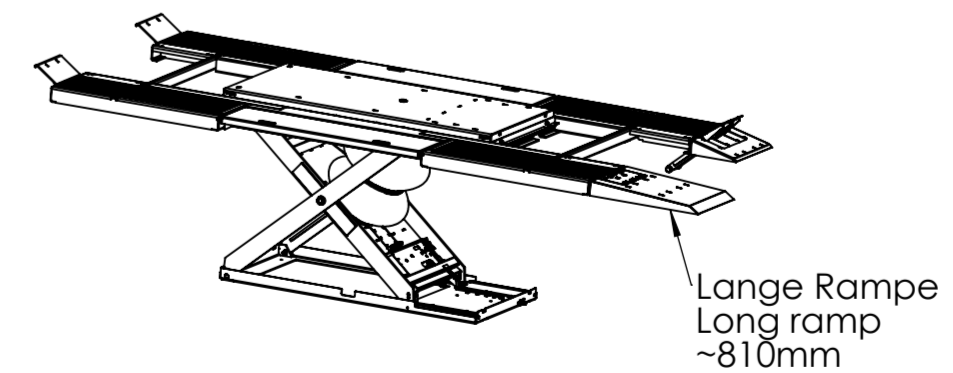

Welding/Schweißen DIN EN ISO 13920-AF	Stamping/Stanz DIN 6930 g	Bending/Biegen DIN 6935	Thermal cutting/Thermisches Schneiden DIN EN ISO 9013-I	Plasma cutting/Plasma Schneiden DIN EN ISO 9013-II
Drawn by/erstellt von AS	Approved by/geprüft von TK	Surface finish/Oberfläche DIN ISO 1302	General Tolerance/Allgemeintoleranzen DIN EN ISO 2768 mK	
Drawn date/Zeichnungserstellung 25.07.2022	Approved date/geprüft am 09.02.2023	Designed by/konstruiert von AS	Comment/Bemerkung	Scale/Maßstab 1:20
Material		Weight/Gewicht 996.79 kg	Sheet format/Blattformat A2	
Description/Beschreibung HLS3513-11		Drawing No./Zeichnungsnummer XL-1-002136	Status Approved	Rev a

The reproduction, distribution and utilization of this document as well as the communication of its contents to others without express authorization is prohibited. Offenders will be held liable for the payment of damages. All rights reserved in the event of the grant of a patent, utility model or design.

Weitergabe sowie Vervielfältigung dieses Dokuments, Verwertung und Mitteilung seines Inhalts sind verboten, soweit nicht ausdrücklich gestattet. Zuwiderhandlungen verpflichten zu Schadenersatz. Alle Rechte vorbehalten für den Fall der Patent-, Gebrauchsmuster- oder Designanmeldung.